

On-Demand Gas Tankless Water Heater Service Manual

Service information for single and multiple unit installations
for residential, commercial, recirculation and storage tank systems.

Series 100/101 & Series 200/201

ATI-305-N	GTS-305-NI	GT-305-NI
ATI-305-P	GTS-305-PI	GT-305-PI
ATO-305-N	GTS-305-NE	GT-305-NE
ATO-305-P	GTS-305-PE	GT-305-PE
ATI-505-N	GTS-505-NI	GT-505-NI
ATI-505-P	GTS-505-PI	GT-505-PI
ATO-505-N	GTS-505-NE	GT-505-NE
ATO-505-P	GTS-505-PE	GT-505-PE
ATI-705-N	GTS-705-NI	GT-705-NI
ATI-705-P	GTS-705-PI	GT-705-PI
ATO-705-N	GTS-705-NE	GT-705-NE
ATO-705-P	GTS-705-PE	GT-705-PE
ATI-705A-N	GTS-705-NIA	AGT-705-NI
ATI-705A-P	GTS-705-PIA	AGT-705-PI
ATO-705A-N	GTS-705-NEA	AGT-705-NE
ATO-705A-P	GTS-705-PEA	AGT-705-PE

Table of Contents

General Information	3-5	<i>PC Board</i>	
Specifications	6, 7	305e/o, 305i, 505e, 505i	27, 28
Schematic Diagrams	8, 9	705e/o (ASME), 705i (ASME)	29
Fault Isolation	10-12		
Electrical Diagnostic Points		<i>Water Flow Control Assembly</i>	
305e/o, 305i, 505e/o 505i	13, 14	305e, 305i, 505e, 505i	30, 31
705e/o (ASME), 705i (ASME)	15, 16	505e, 505i	32, 33
		705e/o (ASME), 705i (ASME)	34
Wire Diagrams		<i>Heat Exchanger</i>	
305e/o, 305i, 505e/o, 505i	17	305e	35-37
705e/o (ASME), 705i (ASME)	18	505e/o.....	38-40
Flushing the Heat Exchanger	19	305i	41-44
Component Replacement Instructions		505i	45-49
<i>Gas Control Assembly</i>		705e/o (ASME).....	50-51
305e/o, 305i, 505e/o, 505i	20, 21	705i (ASME)	52-54
705e/o (ASME), 705i (ASME)	22, 23		
<i>Fan</i>		Gas Pressure Setting Procedure	55, 56
505e/o, 305e/o	24	Manifold Pressure Settings	57
305i, 505i	25	Dip Switches	58
705e/o (ASME), 705i (ASME)	26		

Key to Trade Names in this Manual:
(ASME) Indicates that the ASME models are included.
(N) Indicates Natural Gas.
(P) Indicates Propane Gas.
(e) Indicates Outdoor Models.
(i) Indicates Indoor Models.
(o) Indicates Outdoor Models.

General Information

Safety Definitions



This is the safety alert symbol. This symbol alerts you to potential hazards that can kill or hurt you and others.



Indicates an imminently hazardous situation which, if not avoided, will result in death or serious injury.



Indicates a potentially hazardous situation which, if not avoided, could result in death or serious injury.



Indicates a potentially hazardous situation which, if not avoided, could result in minor or moderate injury. It may also be used to alert against unsafe practices.

Using this Manual

Repairs should be performed by a qualified service technician.

The following information can be referenced for additional information.

- Operation and Installation Manual
- Hot Water System Design Manual
- Technical Sheets
- Technical Bulletins

Technical Support

Visit the brand website for additional support including contact information for our Technical Service Department.

Recommended Tools

- Volt/Ohm/Amp meter with test probes
- Digital manometer or U tube type manometer with 14 inch water column (W.C.) scale, a hose and two 1/8 inch taps
- assorted wrenches including a 3/16 Allen wrench
- assorted screw drivers including a long shafted, magnetic tipped screw driver
- leak solution or leak detector
- Teflon tape

WARNING

There are a number of live tests that are required when fault finding this product. Extreme care should be used at all times to avoid contact with energized components inside the water heater. Before checking for resistance readings disconnect the power source to the unit and isolate the item from the circuit (unplug it).

CAUTION

Label all wires prior to disconnection when servicing controls. Wiring errors can cause improper and dangerous operation.

If any of the original wire as supplied with the appliance must be replaced, it must be replaced with type 18 AWG wire or its equivalent.

General Information

Service Information

The on-demand water heaters must be installed according to all local and state codes or, in the absence of local and state codes, the “National Fuel Gas Code”, ANSI Z223.1 (NFPA 54) - current edition.

CSA American, Inc.
8501 East Pleasant Valley Road
Cleveland, OH 44131

National Fire Protection Association
1 Batterymarch Park
Quincy, MA 02269

Check your phone listings for the local authorities having jurisdiction over your installation.

Massachusetts code requires this water heater to be installed in accordance with Massachusetts Plumbing and Fuel Gas Code 248 CMR Section 2.00 and 5.00.

NOTE: This water heater must be installed according to all local and state codes or, in the absence of local and state codes, the “National Fuel Gas Code”, ANSI Z223.1(NFPA 54)-current edition.

Water Temperature Regulation

For systems with storage tanks, the water temperature in certain situation may vary up to 30°F (16.7°C) higher or lower at the point of use such as, bathtubs, showers, sink, etc. **HOTTER WATER CAN SCALD:** Water heaters, are intended to produce hot water. Water heated to a temperature which will satisfy space heating, clothes washing, dish washing, and other sanitizing needs can scald and permanently injure you upon contact. Some people are more likely to be permanently injured by hot water than others. These include the elderly, children, the infirm, or physically/mentally handicapped. If anyone using hot water in the home fits into one of these groups or if there is a local code or state law requiring a certain temperature water at the hot water tap, then you must take special precautions.

⚠ WARNING

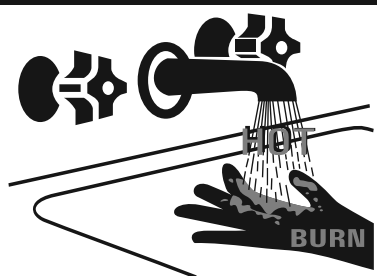

Water temperature over 125°F can cause severe burns instantly or death from scalds.

Children, disabled and elderly are at highest risk of being scalded.

Feel water before bathing or showering.

Temperature limiting valves are available.

In addition to using the lowest possible temperature setting that satisfies your hot water needs, a means such as a mixing valve, should be used at hot water taps used by these people or at the water heater.

Mixing valves are available at plumbing supply or hardware stores. Follow manufacturer’s instructions for installation of the valves. Before changing the factory setting on the thermostat see Table “A”. Using the lowest hot water temperature that meets your needs will also provide the most energy efficient operation of the water heater.

Never allow small children to use a hot water tap, or to draw their own bath water. Never leave a child or handicapped person unattended in a bathtub or shower.

NOTE: A water temperature range of 120°F - 140°F (49°C-60°C) is recommended by most dishwasher manufacturers.

Temperature Settings	Time to Produce 2nd & 3rd Degree Burns on Adult Skin
160°F (71°C)	About 1/2 second
150°F (66°C)	About 1-1/2 seconds
140°F (60°C)	Less than 5 seconds
130°F (54°C)	About 30 seconds
120°F (49°C)	More than 5 minutes
80°F (27°C)	-----

Table “A”

General Information

Closed System/Thermal Expansion

CAUTION - PROPERTY DAMAGE HAZARD

As water is heated, it expands (thermal expansion). In a closed system, the volume of water will grow. As the volume of water grows, there will be a corresponding increase in water pressure due to thermal expansion. Thermal expansion can cause premature tank failure (leakage). This type of failure is not covered under the limited warranty. Thermal expansion can also cause intermittent temperature-pressure relief valve operation: water discharged from the valve due to excessive pressure build up. The temperature / pressure relief valve is not intended for the constant relief of thermal expansion. This condition is not covered under the limited warranty.

A properly-sized thermal expansion tank should be installed on all closed systems to control the harmful effects of thermal expansion. Contact a local plumbing service agency to have a thermal expansion tank installed.

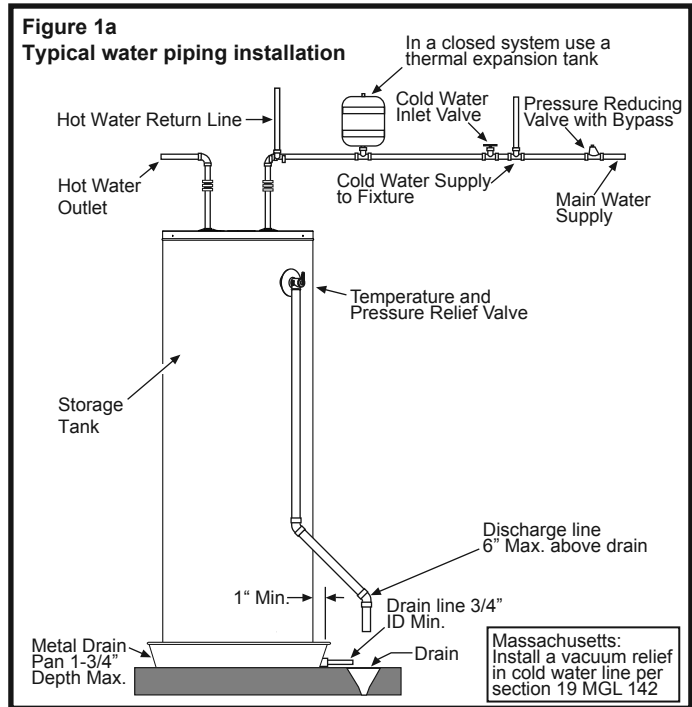

Temperature and Pressure Relief Valve

For protection against excessive pressures and temperatures, a temperature and pressure relief valve must be installed in the opening on the on-demand storage tank. This valve must be design certified by a nationally recognized testing laboratory that maintains periodic inspection of the production of listed equipment or materials as meeting the requirements for Relief Valves for Hot Water Supply Systems, ANSI Z21.22. The function of the temperature and pressure relief valve is to discharge water in large quantities in the event of excessive temperature or pressure developing in the water heater. The valve's relief pressure must not exceed the working pressure the water heater as stated on the data plate.

IMPORTANT: Only a new temperature and pressure relief valve should be used with your water heater. Do not use an old or existing valve as it may be damaged or not adequate for the working pressure of the new water heater. Do not place any valve between the relief valve and the tank.

⚠ WARNING



Explosion Hazard

If the temperature and pressure relief valve is dripping or leaking, have a qualified service technician replace it.

Examples of a qualified service technician include: Licensed plumbers, authorized gas company personnel, and authorized service personnel.

Do not plug valve.

Do not remove valve.

Failure to follow these instructions can result in death, or explosion.

Specifications Residential Series 100/101*

Indoor (i)

Model Number	Input Min. - Max. (BTU)	Flow Rate	Hot water capacity @ 45°F Temp. Rise	Efficiency Rating	Temperature Range
305	15,000 - 199,000 NG 15,000 - 190,000 LP	0.6 - 5.3 GPM (2.3 - 20.1 LPM)	5.3 GPM (20.1 LPM)	84%	98 -140° F (37 - 60° C) [1]
505	15,000 - 199,000 NG 15,000 - 190,000 LP	0.6 - 8.5 GPM (2.3 - 32.0 LPM)	7.4 GPM (28 LPM) NG 7.1 GPM (27 LPM) LP	84%	98 -140° F (37 - 60° C) [2]
705/705 ASME	19,000 - 237,000 NG & LP	0.6 - 9.8 GPM (2.3 - 37 LPM)	8.8 GPM (33.3 LPM)	84%	98 -140° F (37 - 60° C) [2]

Outdoor (e/o)

Model Number	Input Min. - Max. (BTU)	Flow Rate	Hot water capacity @ 45°F Temp. Rise	Efficiency Rating	Temperature Range
305	15,000 - 199,000 NG & LP	0.6 - 5.3 GPM (2.3 - 20.1 LPM)	5.3 GPM (20.1 LPM)	83%	98 -140° F (37 - 60° C) [1]
505	15,000 - 199,000 NG & LP	0.6 - 8.5 GPM (2.3 - 32.0 LPM)	7.3 GPM (27.6 LPM)	83%	98 -140° F (37 - 60° C) [2]
705/705 ASME	19,000 - 237,000 NG & LP	0.6 - 9.8 GPM (2.3 - 37 LPM)	8.7 GPM (32.9 LPM)	83%	98 -140° F (37 - 60° C) [2]

NOTE:

- [1] Minimum activation flow is approximately 0.6 gallons/minute (2.3 liters/min). Max temperature is 160° (71° C) with the commercial controller for commercial and hydronic applications only.
- [2] Max temperature is 185 °F (85 °C) with the commercial controller for commercial and hydronic applications only.

*100 Series is Natural Gas
101 Series is Propane Gas

Specifications

Residential Series

200/201*

Indoor (i)

Model Number	Input Min. - Max. (BTU)	Flow Rate	Hot water capacity @ 45°F Temp. Rise	Efficiency Rating	Temperature Range
305	15,000 - 180,000 NG & LP	0.6 - 7.5 GPM (2.3 - 28.4 LPM)	6.6 GPM (25.0 LPM)	84%	98 -140° F (37 - 60° C) [1]
505	15,000 - 199,000 NG 15,000 - 190,000 LP	0.6 - 9.4 GPM (2.3 - 35.5 LPM)	7.4 GPM (28.0 LPM) NG 7.1 GPM (26.9 LPM) LP	84%	98 -140° F (37 - 60° C) [2]

Outdoor (e/o)

Model Number	Input Min. - Max. (BTU)	Flow Rate	Hot water capacity @ 45°F Temp. Rise	Efficiency Rating	Temperature Range
305	15,000 - 180,000 NG & LP	0.6 - 7.5 GPM (2.3 - 28.4 LPM)	6.6 GPM (25.0 LPM)	83%	98 -140° F (37 - 60° C) [1]
505	15,000 - 199,000 NG & LP	0.6 - 9.4 GPM (2.3 - 35.5 LPM)	7.4 GPM (28.0 LPM)	83%	98 -140° F (37 - 60° C) [2]

NOTE:

[1] Minimum activation flow is approximately 0.6 gallons/minute (2.3 liters/min). Max temperature is 160° (71° C) with the commercial controller for commercial and hydronic applications only.

[2] Max temperature is 185 °F (85 °C) with the commercial controller for commercial and hydronic applications only.

*200 Series is Natural Gas
201 Series is Propane Gas

Schematic Diagrams

Outdoor Model

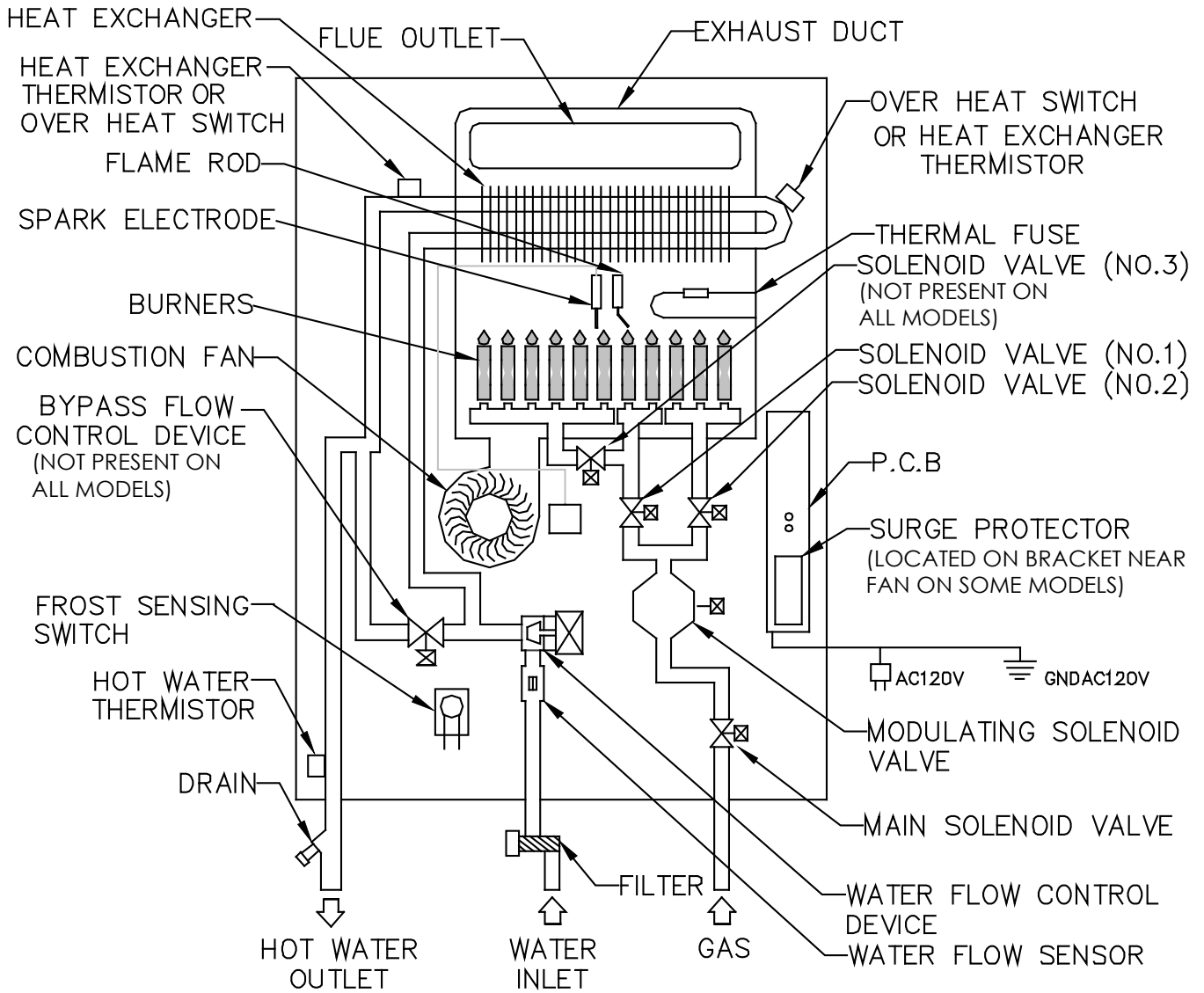

Schematic Diagrams

Indoor Model

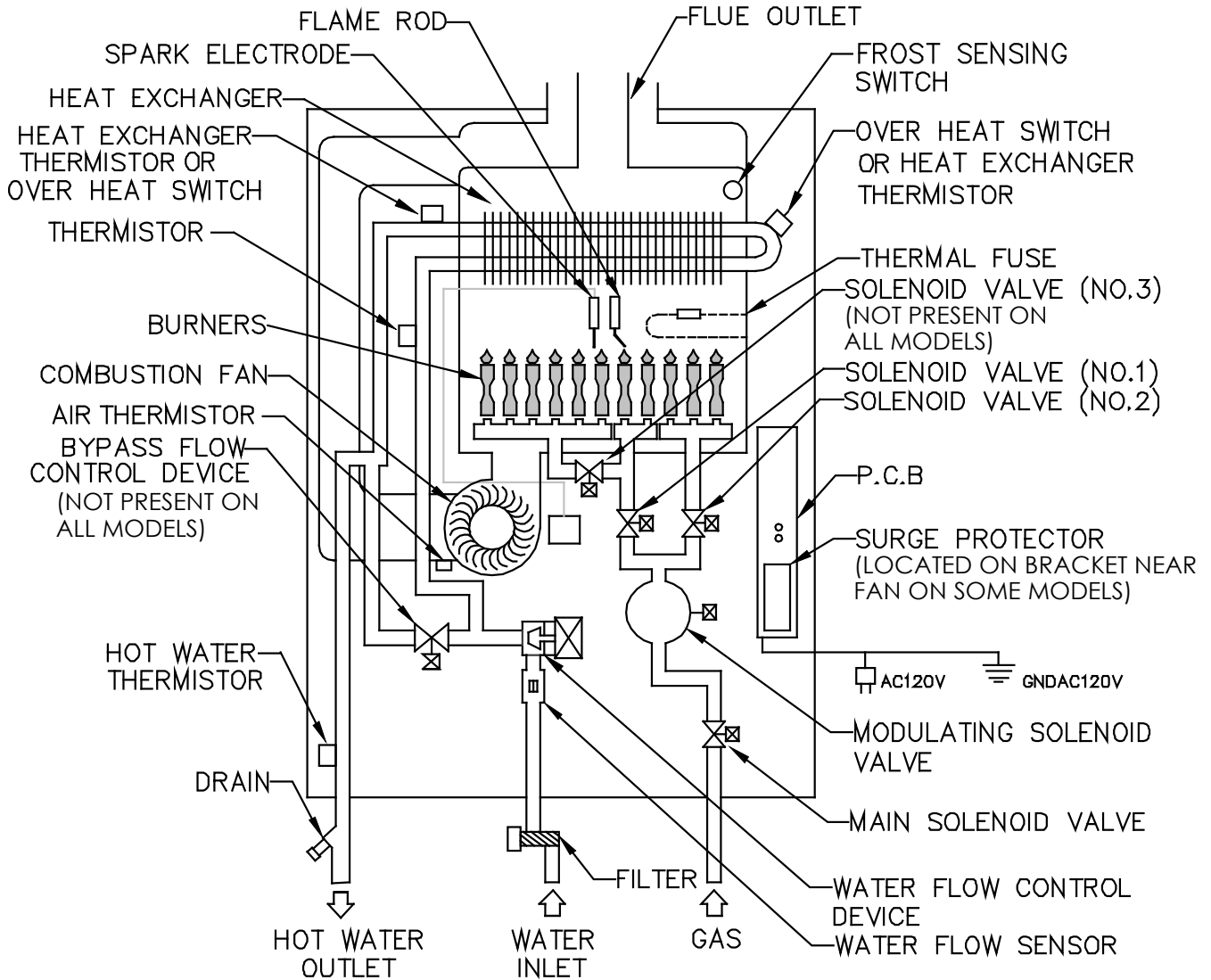

Fault Isolation

The On-Demand water heater has the ability to check its own operation continuously. If a fault occurs, an error code will flash on the display of the remote controller. This assists with diagnosing the fault and may enable you to overcome a problem without a service call.



WARNING

Some of the checks below may need to be done by a qualified service technician. Call a service technician for any remedy that involves gas or electricity. Call a service technician if you have any doubt or reservation about performing the remedy yourself.

Accessing Operating Information

Standard and Commercial Controllers

To display the most recent error codes press and hold the “On/Off” button for 2 seconds. While holding the “On/Off” button press the ▲ button. The last 9 error codes will flash one after the other. To exit this mode press the “On/Off” and ▲ button as before.

To display the water flow through the water heater press and hold the ▲ button for 2 seconds and without releasing the ▲ button press the “On/Off” button.

To display the outlet water temperature press and hold the ▼ button for 2 seconds and without releasing the ▼ button press the “On/Off” button.

Operation

1. Water Flow Begins.

- Water Flow Sensor sends pulses to the PC Board.
- PC Board senses flow greater than 0.6 GPM (approximate).
- Firing Sequence begins.

2. Firing Sequence.

- PC Board monitors inlet/outlet water temperature, temperature set point, and water flow rate.
- Combustion fan energized. Purges combustion chamber.
- Spark igniter begins sparking.
- Gas control valve opens to minimum fire rate.
- Flame rod proves ignition.
- Spark igniter stops sparking.

3. Normal Operation.

- PC Board monitors flame rod, fan motor frequency, outlet water temperature, controller temperature set point and water flow rate.
- Gas control valve modulates gas input to required firing rate.
- Combustion fan speed is adjusted for the required firing rate.
- Water flow control valve is adjusted as needed.

4. Shut-down Sequence.

- PC Board senses flow rate less than 0.5 gpm (approximate).
- Gas control valve closes.
- Water flow control valve resets to standby position.
- Combustion fan runs for a short period of time at low speed.

5. Standby Mode.

- PC Board monitors water temperature and remote controls.
- Freeze protection is activated as needed.

Fault Isolation

Code	Fault	Remedy
02	No burner operation during freeze protection mode	Service Call - Check for possible freeze damage to heat exchanger.
10	Air Supply or Exhaust Blockage	<p>Ensure approved venting materials are being used.</p> <p>Check that nothing is blocking the flue inlet or exhaust.</p> <p>Check all vent components for proper connections.</p> <p>Ensure vent length is within limits.</p> <p>Ensure condensation collar was installed correctly.</p> <p>Verify dip switches are set properly.</p> <p>Check fan for blockage.</p>
11	No Ignition	<p>Check that the gas is turned on at the water heater, gas meter, or cylinder.</p> <p>Ensure gas type and pressure is correct.</p> <p>Ensure gas line, meter, and/or regulator is sized properly.</p> <p>Bleed all air from gas lines.</p> <p>Verify dip switches are set properly.</p> <p>Ensure appliance is properly grounded.</p> <p>Disconnect 2-Unit or Multi-Unit connections to isolate the problem.</p> <p>Ensure igniter is operational.</p> <p>Check igniter wiring harness for damage.</p> <p>Check gas solenoid valves for open or short circuits.</p> <p>Remove burner cover and ensure all burners are properly seated.</p> <p>Remove burner plate and inspect burner surface for condensation or debris.</p>
12	Flame Failure	<p>Check that the gas is turned on at the water heater and gas meter. Check for obstructions in the flue outlet.</p> <p>Ensure gas line, meter, and/or regulator is sized properly.</p> <p>Ensure gas type and pressure is correct.</p> <p>Bleed all air from gas lines.</p> <p>Ensure proper venting material was installed.</p> <p>Ensure condensation collar was installed properly.</p> <p>Ensure vent length is within limits.</p> <p>Verify dip switches are set properly.</p> <p>Ensure appliance is properly grounded.</p> <p>Disconnect keypad.</p> <p>Disconnect all 2-Unit or Multi-Unit connections to isolate the problem.</p> <p>Check power supply for loose connections.</p> <p>Check power supply for proper voltage and voltage drops.</p> <p>Ensure flame rod wire is connected.</p> <p>Remove flame rod and check for carbon build-up; clean with sand paper or emery cloth.</p> <p>Disconnect and reconnect all wiring harnesses on unit and PC board.</p> <p>Check all components for electrical short.</p> <p>Check gas solenoid valves for open or short circuits.</p> <p>Remove burner plate and inspect burner surface for condensation or debris.</p>

Fault Isolation

Code	Fault	Remedy
14	Thermal Fuse	<p>Check gas type of unit and ensure it matches gas type being used.</p> <p>Check for restrictions in air flow around unit and vent terminal.</p> <p>Check for low water flow in a circulating system causing short-cycling.</p> <p>Ensure dip switches are set to the proper position.</p> <p>Check for foreign materials in combustion chamber and/or exhaust piping.</p> <p>Check heat exchanger for cracks and/or separations.</p> <p>Check heat exchanger surface for hot spots which indicate blockage due to scale build-up. Refer to instructions in manual for flushing heat exchanger.</p> <p>Measure resistance of safety circuit.</p> <p>Ensure high fire and low fire manifold pressure is correct.</p> <p>Check for improper conversion of product.</p>
16	Over Temperature Warning	<p>Check for restrictions in air flow around unit and vent terminal.</p> <p>Check for low water flow in a circulating system causing short-cycling.</p> <p>Check for foreign materials in combustion chamber and/or exhaust piping.</p> <p>Check for clogged heat exchanger.</p>
32	Outgoing Water Temperature Sensor Fault	<p>Check sensor wiring for damage.</p> <p>Measure resistance of sensor.</p> <p>Clean sensor of scale build-up.</p> <p>Replace sensor.</p>
33	Heat Exchanger Outgoing Temperature Sensor Fault	<p>Check sensor wiring for damage.</p> <p>Measure resistance of sensor.</p> <p>Clean sensor of scale build-up.</p> <p>Replace sensor.</p>
34	Combustion Air Temperature Sensor Fault	<p>Check for restrictions in air flow around unit and vent terminal.</p> <p>Check sensor wiring for damage.</p> <p>Measure resistance of sensor.</p> <p>Clean sensor of scale build-up.</p> <p>Ensure fan blade is tight on motor shaft and is in good condition.</p> <p>Replace sensor.</p>
52	Modulating Solenoid Valve Signal Abnormal	<p>Check modulating gas solenoid valve wiring harness for loose or damaged terminals.</p> <p>Measure resistance of valve coil.</p>
61	Combustion Fan Failure	<p>Ensure fan will turn freely.</p> <p>Check wiring harness to motor for damaged and/or loose connections.</p> <p>Measure resistance of motor winding.</p>
65	Water Flow Control Fault	<p>The water flow control valve has failed to close during the bath fill function. Immediately turn off the water and discontinue the bath fill function. Contact a state qualified or licensed contractor to service the appliance.</p>
71	SV0, SV1, SV2, and SV3 Solenoid Valve Circuit Fault	<p>Check wiring harness to all solenoids for damage and/or loose connections.</p> <p>Measure resistance of each solenoid valve coil.</p>
72	Flame Sensing Device Fault	<p>Ensure flame rod is touching flame when unit fires.</p> <p>Check all wiring to flame rod for damage.</p> <p>Remove flame rod and check for carbon build-up; clean with sand paper or emery cloth.</p> <p>Check inside burner chamber for any foreign material blocking flame at flame rod.</p> <p>Measure micro amp output of sensor circuit with flame present.</p> <p>Replace flame rod.</p>
LC	Scale Build-up in Heat Exchanger (when checking maintenance code history, "00" is substituted for "LC")	<p>Flush heat exchanger. Refer to instructions in manual.</p> <p>Replace heat exchanger.</p> <p>NOTE: The LC code is the only code that will allow the unit to keep running. The display will alternate between the LC code and the temperature setting. The controller will continue to beep. The LC code will reset if power is turned off and then on.</p>
No code	Nothing happens when water flow is activated.	<p>Clean inlet water supply filter, see page 19 step 12 for cleaning instructions.</p> <p>On new installations ensure hot and cold water lines are not reversed.</p> <p>Check for bleed over. Isolate unit from building by turning off hot water line to building. Isolate the circulating system if present. Open your pressure relief valve; if water is flowing, there is bleed over in your plumbing.</p> <p>Ensure you have at least the minimum flow rate required to fire unit.</p> <p>Ensure turbine spins freely.</p> <p>Measure the resistance of the water flow control sensor.</p>

Electrical Diagnostic Points

305e/o, 305i, 505e/o, 505i

Wire Color	Voltage	Resistance	Connector No.	Pin No.'s
(SV1, SV2, SV3, POV) Gas Valve and Modulating Solenoids				
(Main) Pink - Black	11 - 13 VDC	36.8 - 44.8 ohms	H5	6 ~ 7
(SV1) Black - Yellow			H6	5 ~ 6
(SV2) Black - Blue			H7	4 ~ 6
(SV3) Black - Brown			H8	3 ~ 6
(POV) Pink - Pink	2 - 15 VDC	67 - 81 ohms	H3	9 ~ 10
(M) Water Flow Servo				
Red - Blue	11 - 13 VDC	22 - 26 ohms	F7	9 ~ 10
Gray - Brown	4 - 6 VDC	N/A	F7	5 ~ 7
Gray - Yellow	N/A	N/A	F7	5 ~ 8
NOTE: At the F connector on the PCB: gray wire turns to black, orange wire turns to red				
(QS) Water Flow Sensor				
Black - Red	11 - 13 VDC	5.5 - 6.2 K ohms	F2	1 ~ 3
Yellow - Black	4 - 7 VDC	1 - 1.4 mega ohms	F2	2 ~ 3
Bypass Flow Control (only on 505e/o and 505i)				
Brown - White	2 - 6 VDC (unit in operating mode)	15 - 35 K ohms	G1	1 ~ 5
Orange - White				2 ~ 5
Yellow - White				3 ~ 5
Red - White/Ground				4 ~ 5
(IG) Ignition System				
Gray - Gray	90 - 110 VAC	N/A	C1	1 ~ 2
(FM) Combustion Fan Motor				
Red - Black	6 - 45 VDC	N/A	E1	1 ~ 2
White - Black	5 - 10 VDC	9.2 - 9.4 K ohms	E1	2 ~ 4
Yellow - Black	11 ~ 13 VDC	3.5 - 3.9 K ohms	E1	2 ~ 3
With the meter set on hertz scale, 60-420 hertz should be across the red and yellow wires at terminals 2 and 4.				

Electrical Diagnostic Points

305e/o, 305i, 505e/o, 505i

Wire Color	Voltage	Resistance	Connector No.	Pin No.'s
Thermal Fuse / Overheat Switch				
Red - Red	11 - 13 VDC	below 1 ohm	F6 H1	F6 ~ H12
Flame Rod				
Place one lead of the meter to the flame rod and the other to ground. With the unit running, 5-150 VAC should be read. Set the meter to the μ amp scale and series the meter in line with the flame rod. Proper flame circuit should read 1 μ amp or greater. If not, then remove the flame rod and check for carbon and damage.				
Thermistors				
Check all thermistors by inserting meter leads into each end of the thermistor plug. Set the meter to the 20 K ohm scale and read resistance. Applying heat to the thermistor bulb should decrease the resistance. Applying ice to the thermistor bulb should increase the resistance. Typical resistance values are: 11.4-14 K ohm for 59°F; 6.4-7.8 K ohm for 86°F; 3.6-4.5 K ohm for 113°F; 2.2-2.7 K ohm for 140°F; 0.6-0.8 K ohm for 221°F				
Outgoing Water Thermistor				
White - White	see above		F5	3 ~ 4
Heat Exchanger Temperature Thermistor				
Pink - White	see above		F4	3 ~ 11
Intake Air Thermistor				
Orange - White	see above		F3	3 ~ 12
Surge Protector				
Black - White	108 - 132 VAC	N/A	D2	1 ~ 3
Blue - Brown	108 - 132 VAC	N/A	D1	1 ~ 3
With the power off, check the continuity through the surge protector. Check by placing one meter lead on the top pin #1 and bottom pin #3. Check by placing one meter lead on the top pin #3 and bottom pin #1. If there is continuity across both sets of points, then the surge protector is good.				
Controller				
Terminals B1	10 - 13 VDC	1.5 - 3.0 K ohms	B	1 ~ 3
Frost Protection				
There are electrical heating elements mounted at different points to protect the water heater from freezing.				
heaters located on the hot water outlet line		180 - 207 ohms		
heater located on heat exchanger piping		156 - 180 ohms		
heater located on water flow sensor		24 - 28 ohms		
Amp fuses				
There are two inline 3 amp glass fuses. Remove the fuse and check continuity through it. If there is continuity then the fuse is good.				

Electrical Diagnostic Points

705e/o (ASME),
705i (ASME)

Wire Color	Voltage	Resistance	Connector No.	Pin No.'s
(SV1, SV2, SV3, POV) Gas Valve and Modulating Solenoids				
(Main) Pink - Black	11 - 13 VDC	24 - 28 ohms	H3	6 ~ 7
(SV1) Black - Red		37 - 43 ohms	H4	5 ~ 6
(SV2) Black - Orange		37 - 43 ohms	H5	4 ~ 6
(SV3) Black - Yellow		37 - 43 ohms	H6	3 ~ 6
(POV) Orange - Orange	2 - 15 VDC	67 - 81 ohms	H2	9 ~ 10
(M) Water Flow Servo				
Red - Blue	11 - 13 VDC	22 - 28 ohms	F5	9 ~ 10
Gray - Brown	4 - 6 VDC	N/A	F5	5 ~ 7
Gray - Yellow	N/A	N/A	F5	5 ~ 8
NOTE: At the F connector on the PCB: gray wire turns to black				
(QS) Water Flow Sensor				
Black - Red	11 - 13 VDC	5.5 - 6.2 K ohms	F2	1 ~ 3
Yellow - Black	4 - 7 VDC	1 - 1.4 mega ohms	F2	2 ~ 3
Bypass Flow Control				
Brown - White	2 - 6 VDC (unit in operating mode)	15 - 35 K ohms	G1	1 ~ 5
Orange - White				2 ~ 5
Yellow - White				3 ~ 5
Red - White/Ground				4 ~ 5
(IG) Ignition System				
Gray - Gray	90 - 110 VAC	N/A	C1	1 ~ 2
(FM) Combustion Fan Motor				
Red - Black	6 - 45 VDC	N/A	E1	1 ~ 2
White - Black	5 - 10 VDC	9.2 - 9.4 K ohms	E1	2 ~ 4
Yellow - Black	11 ~ 13 VDC	3.5 - 3.9 K ohms	E1	2 ~ 3
With the meter set on hertz scale, 60-420 hertz should be across the red and yellow wires at terminals 2 and 4.				

Electrical Diagnostic Points

705e/o (ASME),
705i (ASME)

Wire Color	Voltage	Resistance	Connector No.	Pin No.'s
Thermal Fuse / Overheat Switch				
Red - White	11 - 13 VDC	below 1 ohm	F6 H1	F6 ~ H12
Flame Rod				
Place one lead of the meter to the flame rod and the other to ground. With the unit running, 5-150 VAC should be read. Set the meter to the μ amp scale and series the meter in line with the flame rod. Proper flame circuit should read 1 μ amp or greater. If not, then remove the flame rod and check for carbon and damage.				
Thermistors				
Check all thermistors by inserting meter leads into each end of the thermistor plug. Set the meter to the 20 K ohm scale and read resistance. Applying heat to the thermistor bulb should decrease the resistance. Applying ice to the thermistor bulb should increase the resistance. Typical resistance values are: 11.4-14 K ohm for 59°F; 6.4-7.8 K ohm for 86°F; 3.6-4.5 K ohm for 113°F; 2.2-2.7 K ohm for 140°F; 0.6-0.8 K ohm for 221°F				
Outgoing Water Thermistor				
White - White	see above		F4	3 ~ 4
Heat Exchanger Temperature Thermistor				
Pink - White	see above		F3	3 ~ 11
Surge Protector				
Black - White	108 - 132 VAC	N/A	D2	1 ~ 3
Blue - Brown	108 - 132 VAC	N/A	D1	1 ~ 3
With the power off, check the continuity through the surge protector. Check by placing one meter lead on the top pin #1 and bottom pin #3. Check by placing one meter lead on the top pin #3 and bottom pin #1. If there is continuity across both sets of points, then the surge protector is good.				
Controller				
Terminals B1	10 - 13 VDC	1.5 - 3.0 K ohms	B	1 ~ 3
Frost Protection				
There are electrical heating elements mounted at different points to protect the water heater from freezing. Voltage through this circuit should be 120 VAC.				
heater located on the hot water outlet line		180 - 207 ohms		
heater located on heat exchanger piping		156 - 180 ohms		
heater located on water flow sensor		24 - 28 ohms		
Amp fuses				
There are two inline 3 amp glass fuses. Remove the fuse and check continuity through it. If there is continuity then the fuse is good.				

Wiring Diagram

305e/o, 305i, 505e/o, 505i

COLOR CODING

W : White
 BK : Black
 BR : Brown
 R : Red
 BL : Blue
 Y : Yellow
 P : Pink
 O : Orange
 G : Green
 GY : Gray

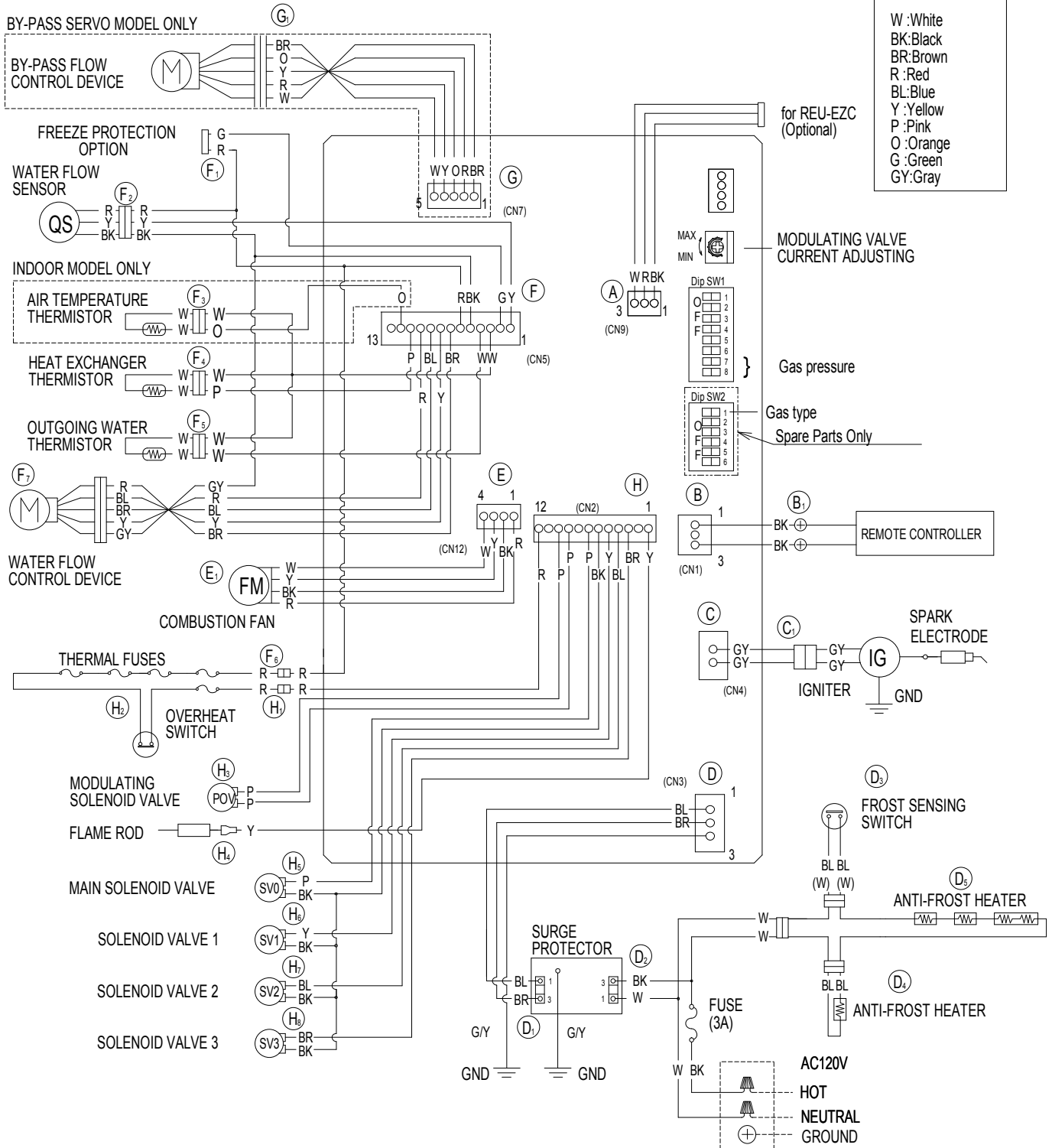

Wiring Diagram

705e/o (ASME),
705i (ASME)

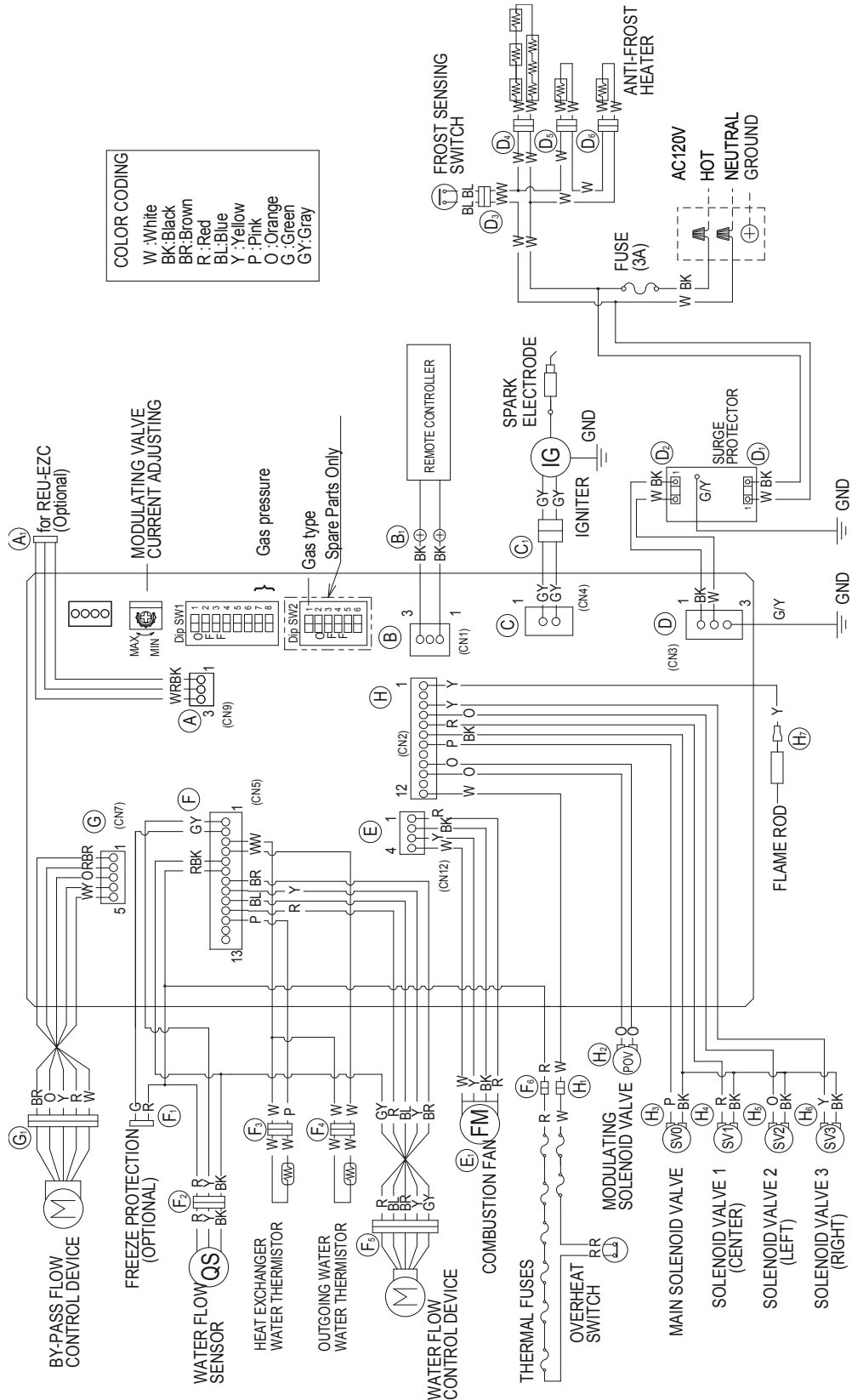

Flushing the Heat Exchanger

An "LC" or "00" error code indicates the unit is beginning to lime up and must be flushed. Failure to flush the appliance will cause damage to the heat exchanger. Damage caused by lime build-up is not covered by the unit's warranty. After flushing, reset the LC fault code by turning off the power to the unit and turning the power back on.

1. Disconnect electrical power to the water heater.
2. Close the shutoff valves on both the hot water and cold water lines (V3 and V4).
3. Connect pump outlet hose (H1) to the cold water line at service valve V2.
4. Connect drain hose (H3) to service valve V1.
5. Pour approximately 4 gallons of virgin, food grade, white vinegar or citric acid into pail.
6. Place the drain hose (H3) and the hose (H2) to the pump inlet into the cleaning solution.
7. Open both service valves (V1 and V2) on the hot water and cold water lines.
8. Operate the pump and allow the cleaning solution to circulate through the water heater for at least 45 minutes.
9. Turn off the pump.
10. Rinse the cleaning solution from the water heater as follows:
 - a. Remove the free end of the drain hose (H3) from the pail.
 - b. Close service valve, (V2), and open shutoff valve, (V4). Do not open shutoff valve, (V3).
 - c. Allow water to flow through the water heater for 5 minutes
 - d. Close service valve, (V1), and open shutoff valve, (V3).
11. Disconnect all hoses.

IN-LINE CLEANING FILTER INSTRUCTIONS:

12. With (V4) closed, remove the in-line filter at the cold water inlet and clean out any residue. Place filter back into unit and open (V4).
13. Restore electrical power to the water heater.

5 gallon pail of virgin, food grade, white vinegar (or virgin, food grade, citric acid).

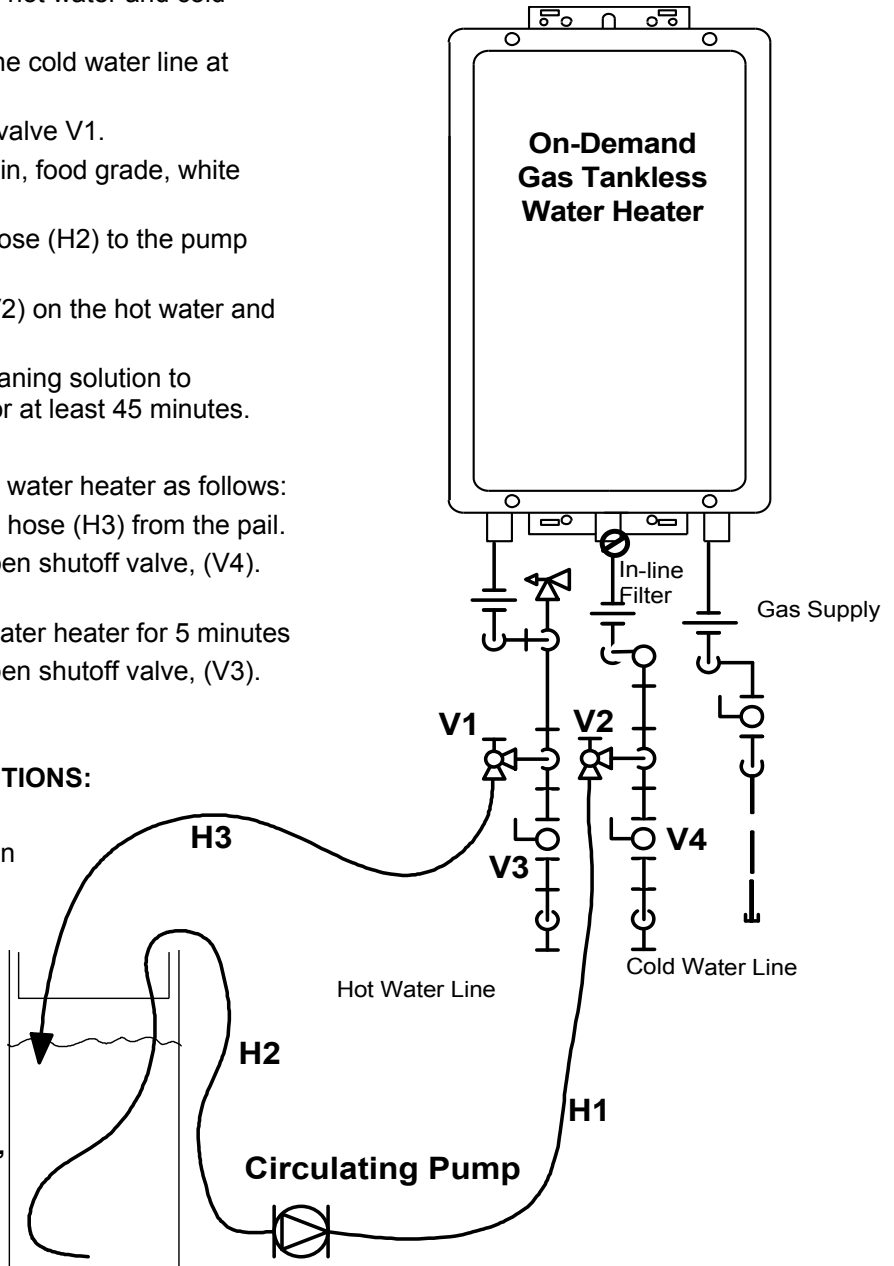

KEY

	3/4" Ball Valve		Pressure Regulator
	3/4" Union		Circulating Pump
	Check Valve		Boiler Drain Valve
	Pressure Relief Valve		Solenoid Valve

Component Replacement Instructions

305e/o, 305i, 505e/o, 505i

Gas Control Assembly

1. Turn off the gas supply.
2. Turn off the 120 V power supply.
3. Remove four screws securing the front panel. Remove front panel.
4. Pull out wire harness connector at the gas manifold assembly. See Figure 1.
5. Move aside the ignition line by pulling it out from the clear plastic tubing.
6. Remove the six screws that attach the gas manifold to the combustion chamber (part of the heat exchanger assembly).
7. Remove the three screws that attach the gas manifold to the gas valve. Pull out the gas manifold.

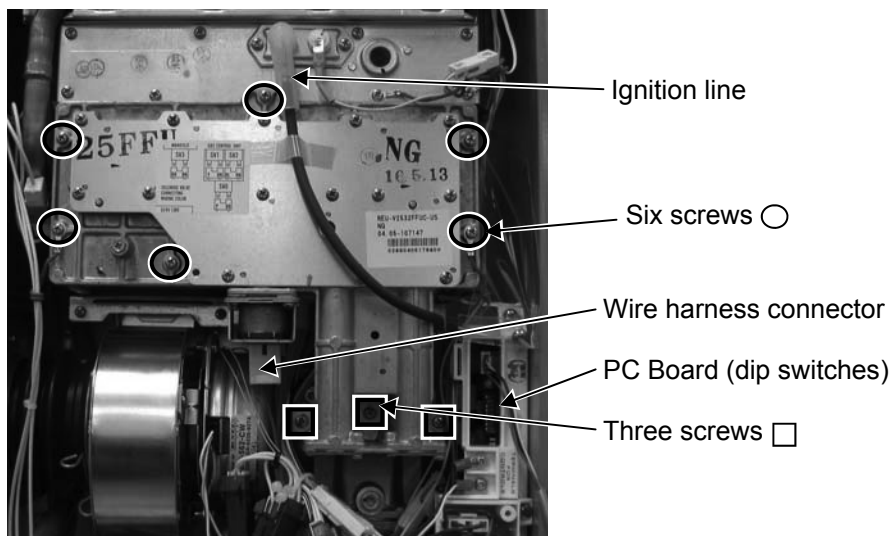

Figure 1

8. Remove the four screws attaching the gas connection to the underneath side of the water heater. See Figure 2.

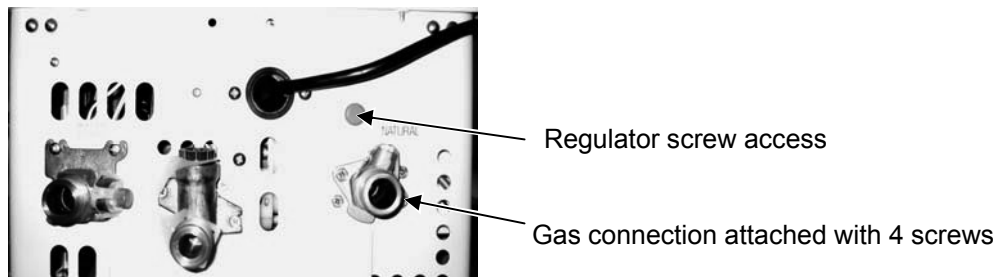

Figure 2

9. Pull the gas connection down to disconnect it from the gas control assembly.
10. Pull out the gas control assembly. Remove the wire harness from the 4 solenoids.

WARNING Failure to correctly assemble the components according to these instructions could result in a gas leak or explosion.

11. Replace the O-ring (included in kit) where the assembly attaches to the gas connection. Make sure the old O-ring is removed and discarded. Install the new gas control assembly.

Component Replacement Instructions

305e/o, 305i, 505e/o, 505i

Gas Control Assembly

12. Attach wire harness to the 4 solenoids as shown in Figure 3 below.

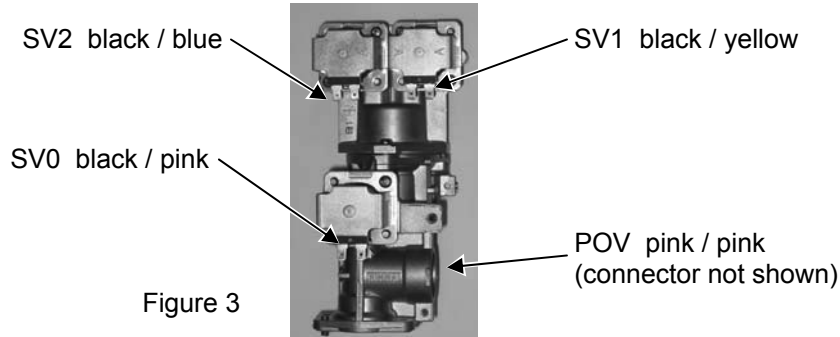

13. Install the gas manifold using 2 new packings (included in kit) between the manifold and the heat exchanger. Replace the two circular gaskets (included in kit) in the gas valve (Figure 5).

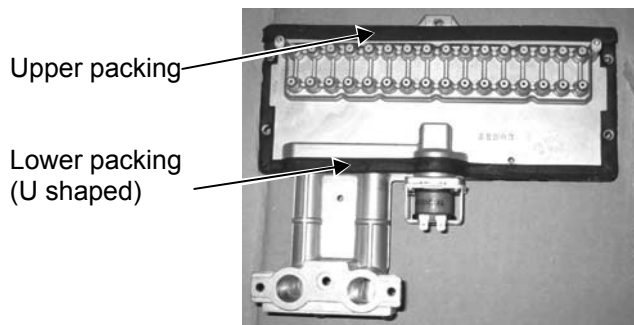

Figure 4

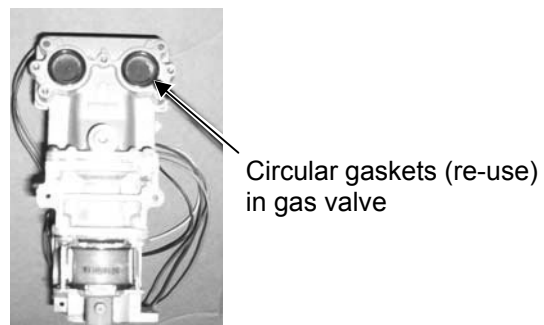

Figure 5

14. Start the three screws that attach the gas manifold to the gas valve. Tighten the six screws that hold the gas manifold to the combustion chamber. Finish tightening the three screws that hold the gas manifold to the gas valve.

15. Attach wiring harness connector (black & brown wires) to the gas manifold.

16. Attach ignition line.

17. Perform the Gas Pressure Setting Procedure.

Component Replacement Instructions

705e/o (ASME),
705i (ASME)

Gas Control Assembly

1. Turn off the gas supply.
2. Turn off the 120 V power supply.
3. Remove four screws securing the front panel. Remove front panel.
4. On indoor models, remove the bracket holding the controller (1 screw). (Figure 6)
5. Move aside the ignition line by pulling it out from the clear plastic tubing. (Figure 6)
6. Remove the 5 screws that attach the gas manifold to the combustion chamber (part of the heat exchanger assembly). (Figure 7)
7. Remove the 2 screws that attach the gas manifold to the gas valve. These screws are machine screws and must be used at these locations. (Figure 7)
8. Pull out the gas manifold and remove the connector at the ignitor at the left side of the gas manifold.
9. Remove the 3 screws attaching the gas connection to the underneath side of the water heater. (Figure 8)
10. Remove the screw attaching the gas valve to the rear of the case.
11. Pull the gas connection down to disconnect it from the gas control assembly.

Bracket screw

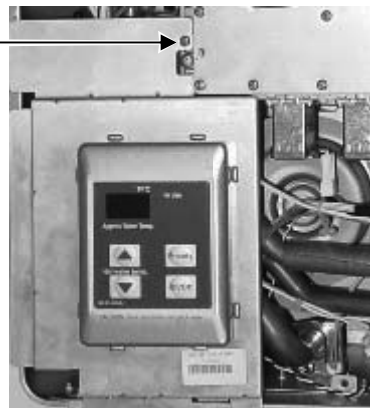

Figure 6
(indoor models)

5 screws ○
(gas manifold)

2 machine screws □
(gas valve)

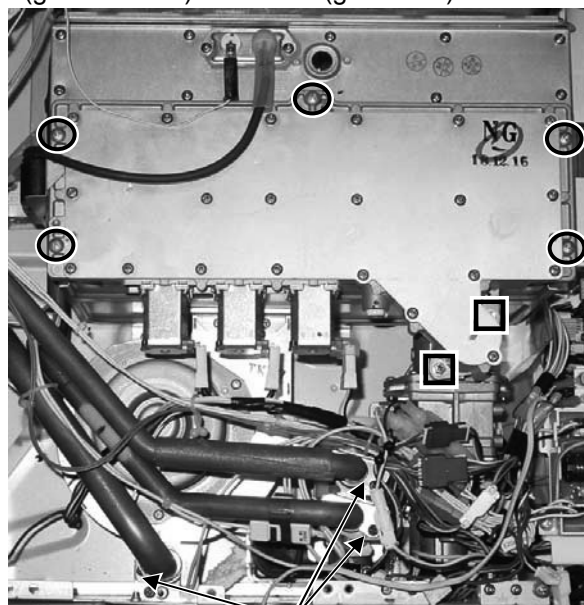

Figure 7

Water line connections



Figure 8

Regulator screw access
Gas connection attached with 3 screws

Component Replacement Instructions

705e/o (ASME),
705i (ASME)

Gas Control Assembly

WARNING Failure to correctly assemble the components according to these instructions could result in a gas leak or explosion.

12. Pull out the gas control assembly. Remove the wire harness from the 2 solenoids.
13. Install the gas valve and attach the wire harness to the 2 solenoids. (Figure 9)

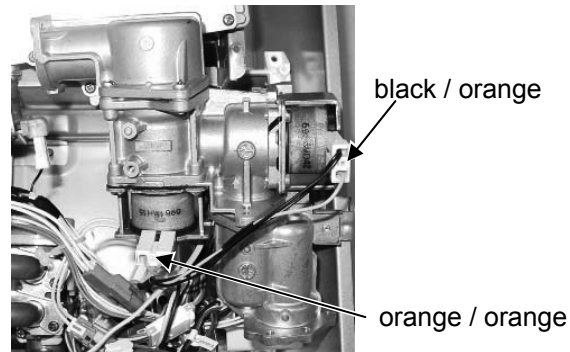

Figure 9

14. Install the gas connection with 3 screws.
15. Replace the circular gasket (included in kit) in the gas valve. (Figure 10)
16. Start the 2 screws that attach the gas manifold to the gas valve. Tighten the 5 screws that hold the gas manifold to the combustion chamber. Finish tightening the 2 screws that hold the gas manifold to the gas valve.
17. Attach ignition line.
18. On indoor models, install the bracket with the controller.
19. Perform the Gas Pressure Setting Procedure.

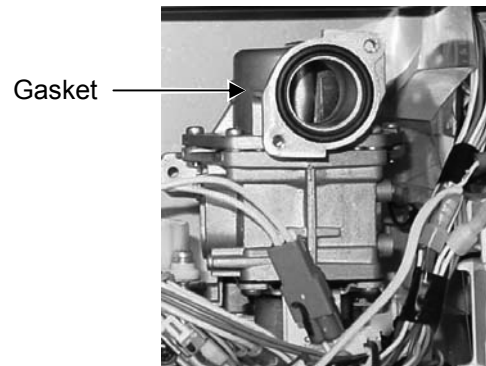

Figure 10

Component Replacement Instructions

305e/o, 505e/o

Fan

1. Turn off the gas supply.
2. Turn off the 120 V power supply.
3. Turn off the water supply.
4. Remove four screws securing the front panel. Remove front panel.
5. Disconnect wire harness at the fan assembly. Disconnect the air temperature thermistor (two white wires) at the connection with the white and orange wires within the wire bundle.
6. Pull out the harness attached to the solenoid on the manifold to make room to pull out the fan assembly.
7. Remove the two screws that attach the fan assembly to the bottom of the burner.

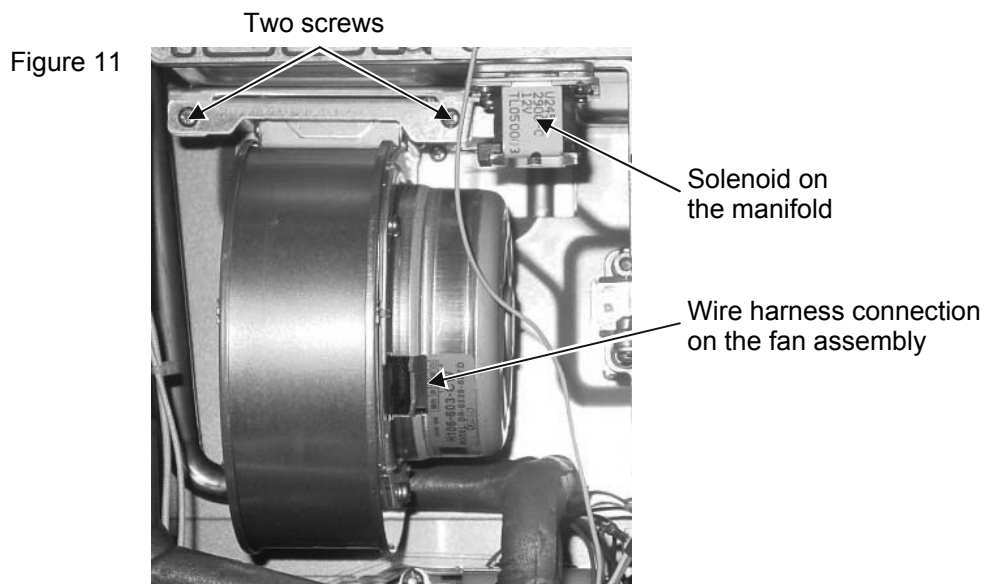

8. Pull out the fan assembly.
9. Install the fan assembly by inserting the tab on the fan assembly into the slot at the base of the heat exchanger and attaching with two screws.
10. Attach the wire harness to the solenoid on the gas manifold (brown, black wires).
11. Attach the wire harness to the fan assembly (white, yellow, black, red wires).
12. Attach the air temperature thermistor (white, white wires) to the wire harness.
13. Install front panel using 4 screws.
14. Turn on water supply, power supply, and gas supply.

Component Replacement Instructions

305i, 505i

Fan

1. Turn off the gas supply.
2. Turn off the 120 V power supply.
3. Turn off the water supply.
4. Remove four screws securing the front panel. Remove front panel.
5. Disconnect wire harness at the fan assembly. Disconnect the air temperature thermistor (two white wires) at the connection with the white and orange wires within the wire bundle.
6. Pull out the harness attached to the solenoid on the manifold to make room to pull out the fan assembly.
7. Loosen the ducting from the fan assembly by pinching open the metal clamp.

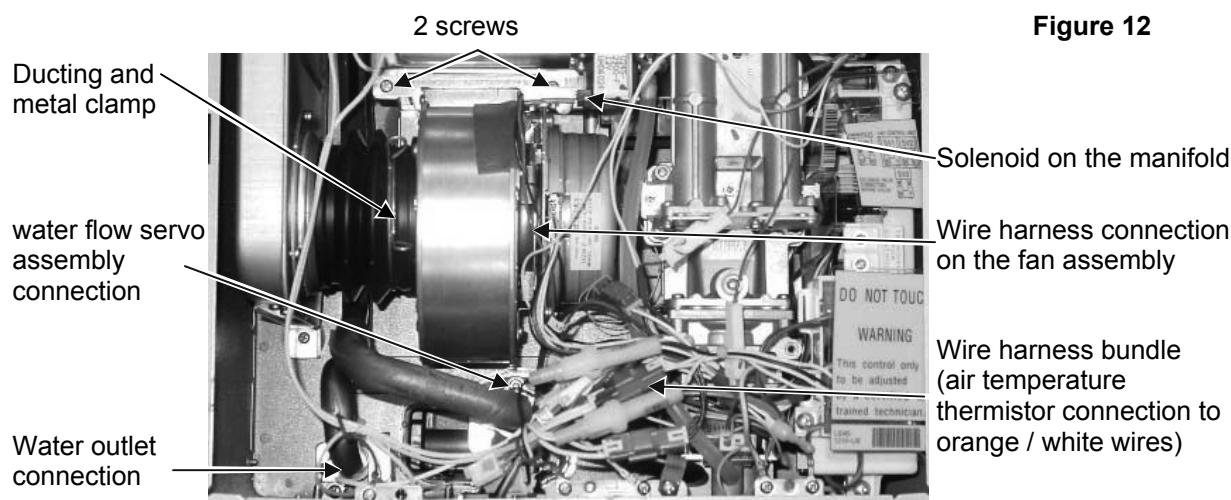

8. Remove the two screws that attach the fan assembly to the bottom of the burner.
9. Pull out the fan assembly.
10. Install the fan assembly by inserting the tab on the fan assembly into the slot at the base of the heat exchanger and attaching with two screws.
11. Push ducting over fan assembly inlet and secure with metal clamp.
12. Attach the wire harness to the solenoid on the gas manifold (brown, black wires).
13. Attach the wire harness to the fan assembly (white, yellow, black, red wires).
14. Attach the air temperature thermistor (white, white wires) to the wire harness.
15. Install front panel using 4 screws.
16. Turn on water supply, power supply, and gas supply.

Component Replacement Instructions

705e/o (ASME),
705i (ASME)

Fan

1. Turn off the gas supply.
2. Turn off the 120 V power supply.
3. Turn off the water supply.
4. Remove four screws securing the front panel. Remove front panel.
5. On indoor models, remove the bracket holding the controller (1 screw). (Figure 13)
6. Disconnect the wire harness at the fan assembly. (Figure 14)
7. Remove the three screws attaching the fan motor to the fan casing. (Figure 14)
8. Pull out the fan motor.
9. Install the new fan motor and tighten with three screws.
10. Attach the wire harness to the fan assembly (white, yellow, black, red wires).
11. On indoor models, install the bracket with the remote controller.
12. Install front panel using 4 screws.
13. Turn on water supply, power supply, and gas supply.

Bracket screw

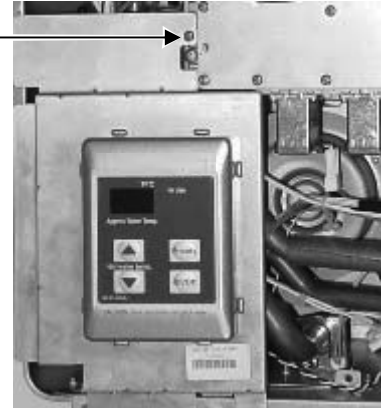

Figure 13
(indoor models)



Wire Harness Connector

3 screws

Figure 14

Component Replacement Instructions

305e/o, 305i, 505e/o, 505i

PC Board

1. Turn off the gas supply.
2. Turn off the 120 V power supply.
3. Turn off the water supply.
4. Remove four screws securing the front panel.
Remove front panel.
5. Remove the plastic guard covering the front of the PC board.
6. Remove the controller connections.
7. If a surge protector with terminals is installed, then remove this board by removing two screws. This board should be re-installed on the replacement PC board.
8. Remove the two screws at the top and bottom of the PC board.
9. Pull out the PC board, remove plastic cover, and remove the connections.
10. Adjust dip switches on the new PC board.

Switches 1-8 (SW1): Configure the dip switches the same as on the original PC board. If necessary, refer to the Dip Switch section or to the Operation and Installation Manual for more information on these dip switches.

Switches 1-6 (SW2): Replacement PC boards have an additional bank of 6 dip switches. Configure according to the diagrams on the following page based on your model and gas type.

11. Attach connections and plastic cover.
12. Insert PC board and attach with two screws.
13. If a surge protector with terminals was installed on the original PC board, remove it and install it on the new PC board. See Figure 15.
14. Attach connections for the remote controller.
15. Attach plastic guard.
16. Perform the Gas Pressure Setting Procedure.

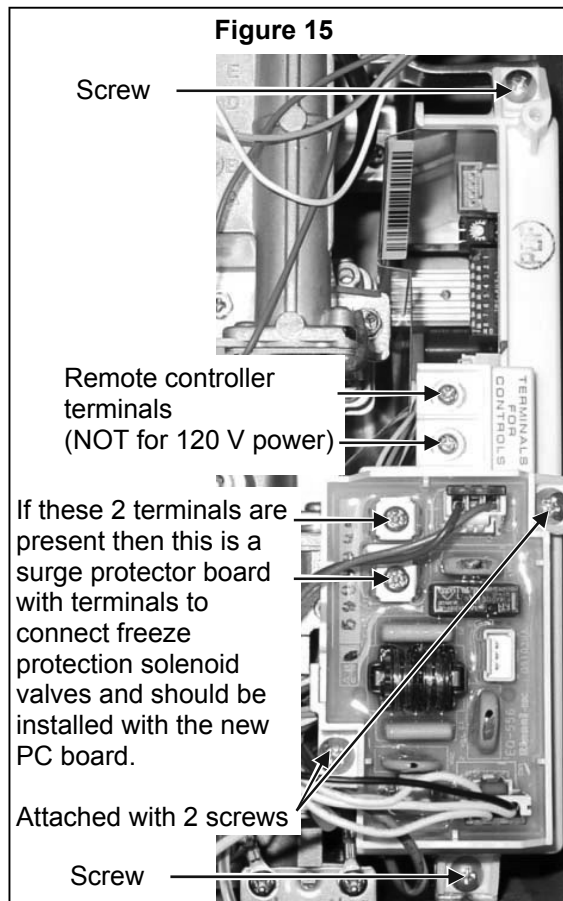

Component Replacement Instructions

305i, 305e, 505i, 505e
100/101 and 200/201 Series

PC Board

SW2 setup for 505i

Propane (LPG) Natural Gas (NG)

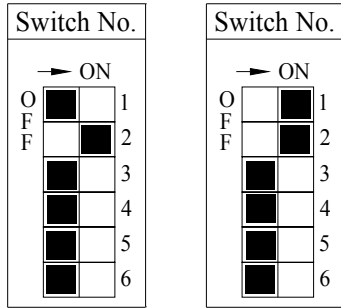

SW2 setup for 505e

Propane (LPG) Natural Gas (NG)

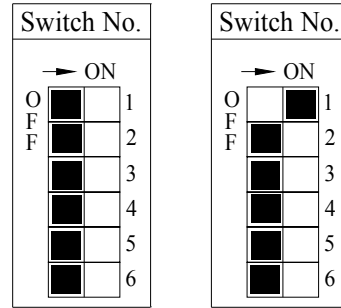

SW2 setup for 305i

Propane (LPG) Natural Gas (NG)

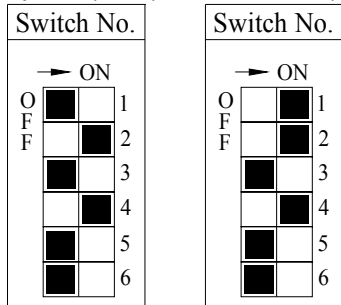

SW2 setup for 305e

Propane (LPG) Natural Gas (NG)

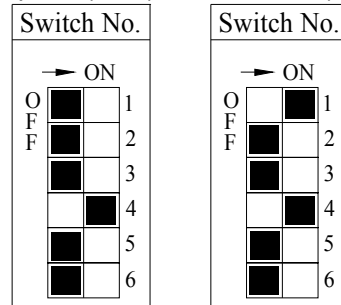

Component Replacement Instructions

705e/o (ASME), 705i (ASME)

PC Board

1. Turn off the gas supply.
2. Turn off the 120 V power supply.
3. Remove four screws securing the front panel. Remove front panel.
4. Remove the surge protector (2 screws)
5. Remove the 2 screws connecting the PC board to the water heater casing.
6. Pull out the PC board and remove the connections.
7. Adjust dip switches on the new PC board.

Switches 1-8 (SW1):

Configure the dip switches the same as on the original PC board. If necessary, refer to the Dip Switch section or to the Operation and Installation Manual for more information on these dip switches.

Switches 1-4 (SW2) or Switches 1-6 (SW2):

Configure according to the diagrams based on your model and gas type.

8. Attach connections and insert PC board. Attach with 2 screws.
9. Attach the surge protector with 2 screws.
10. Perform the Gas Pressure Setting Procedure.

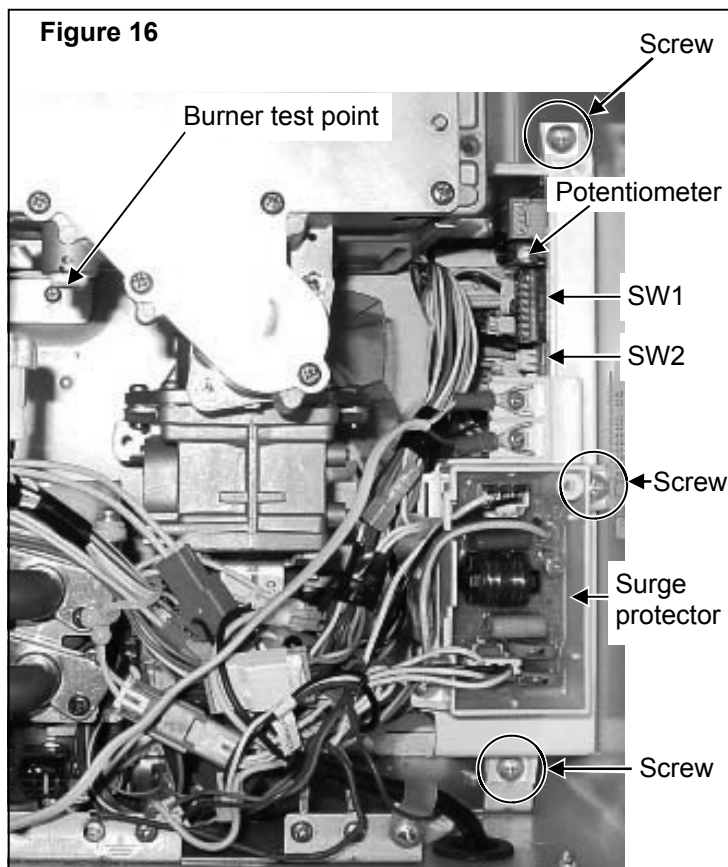

SW2 setup for 705i

Propane (LPG) Natural Gas (NG)

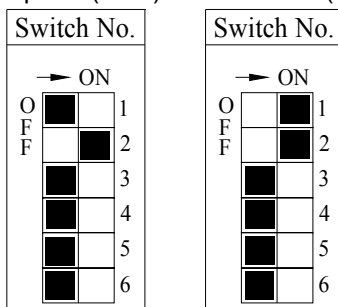

SW2 setup for 705e/o

Propane (LPG) Natural Gas (NG)

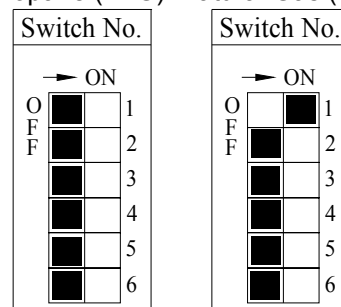

Component Replacement Instructions

305e/o, 305i, 505e/o, 505i
100/101 and 200/201 Series

Water Flow Control Assembly

NOTICE Due to design changes, the new valve may appear different than the installed valve in color, size, and in the number of wires in the harness connections.

1. Turn off the gas supply.
2. Turn off the 120 V power supply.
3. Turn off the water supply. Drain all water from the appliance.
4. Remove four screws securing the front panel. Remove front panel.

Remove the water flow assembly

5. Remove 1 screw and bracket at the water flow assembly. The bracket can be left on the water line. Pull out the water line. (Figure 17)

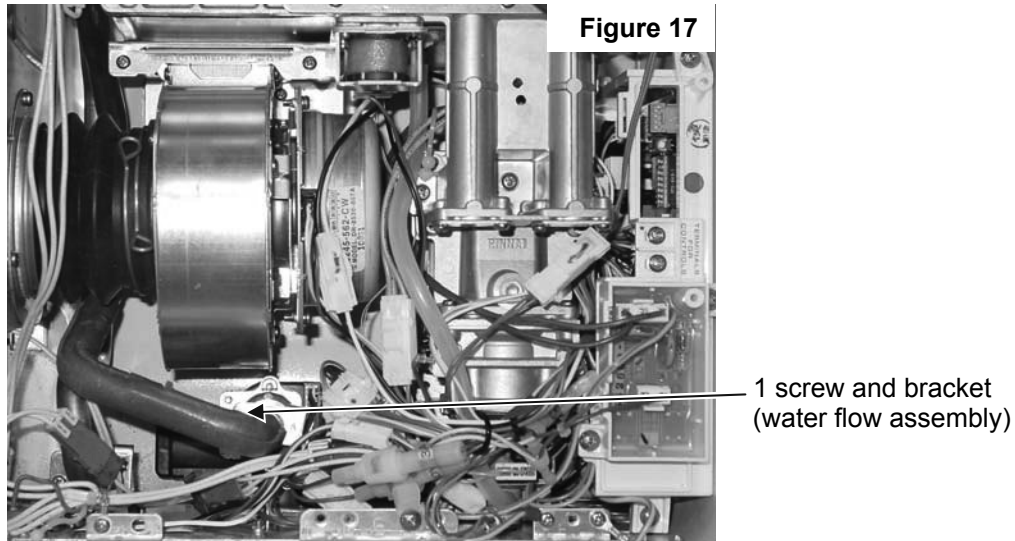

6. Remove the 4 screws attaching the water inlet to the underneath side of the water heater. (Figure 18).

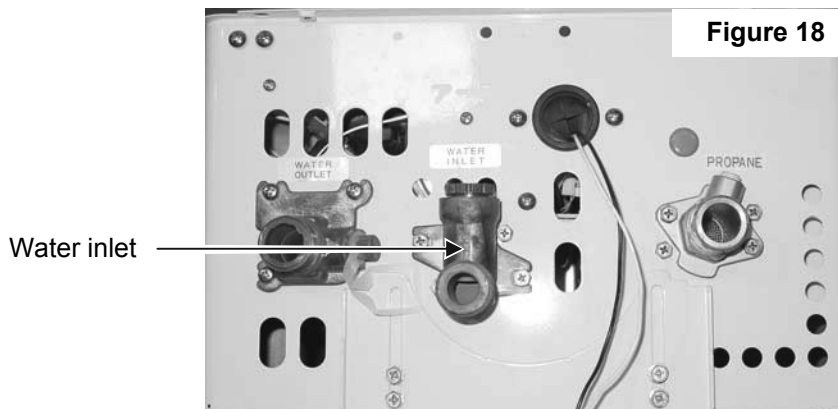

Component Replacement Instructions

305e, 305i, 505e, 505i
100/101 and 200/201 Series

Water Flow Control Assembly

7. Pull out the water flow servo assembly and disconnect the cable harnesses. (Figure 19)
 - A. water flow sensor harness (black/yellow/red wires)
 - B. water flow servo harness (red/blue/brown/yellow/gray or red/blue/brown/orange/yellow/gray wires)
 - C. heating element

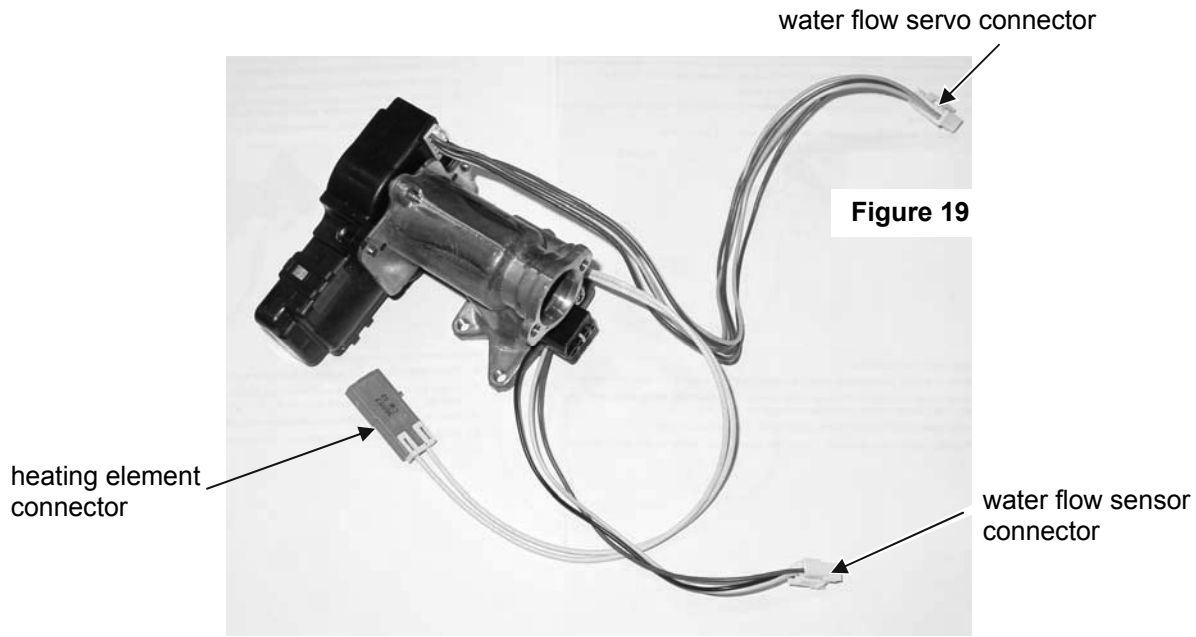

Assemble

8. Place the new water flow assembly inside the water heater and attach the cable harnesses.
9. Replace the O-ring on the water inlet (included in kit). Attach the water flow assembly through the bottom of the compartment to the water inlet using 4 screws. The 2 shorter screws can be installed first to connect the water flow assembly to the bottom of the compartment. Then install the 2 longer screws through the water inlet.
10. Replace the O-ring on the water line (included in kit). Attach the water line to the water flow assembly with 1 screw and bracket.
11. Install the front panel using 4 screws.
12. Turn on the water supply, power supply, and gas supply.
13. Open a hot water tap and ensure there are no leaks at the water heater.

Component Replacement Instructions

505e/o, 505i
100/101 and 200/201 Series

Water Flow Control Assembly

NOTICE

Due to design changes, the new valve may appear different than the installed valve in color, size, and in the number of wires in the harness connections.

1. Turn off the gas supply.
2. Turn off the 120 V power supply.
3. Turn off the water supply. Drain all water from the appliance.
4. Remove four screws securing the front panel. Remove front panel.

Remove Fan Assembly (Figure 20)

5. Disconnect wire harness at the fan assembly. Disconnect the air temperature thermistor (two white wires) at the connection with the white and orange wires within the wire bundle.
6. Pull out the harness attached to the solenoid on the manifold to make room to pull out the fan assembly.
7. Remove the 2 screws that attach the fan assembly to the bottom of the burner.
8. On indoor models, loosen the ducting from the fan assembly by pinching open the metal clamp.
9. Pull out the fan assembly.

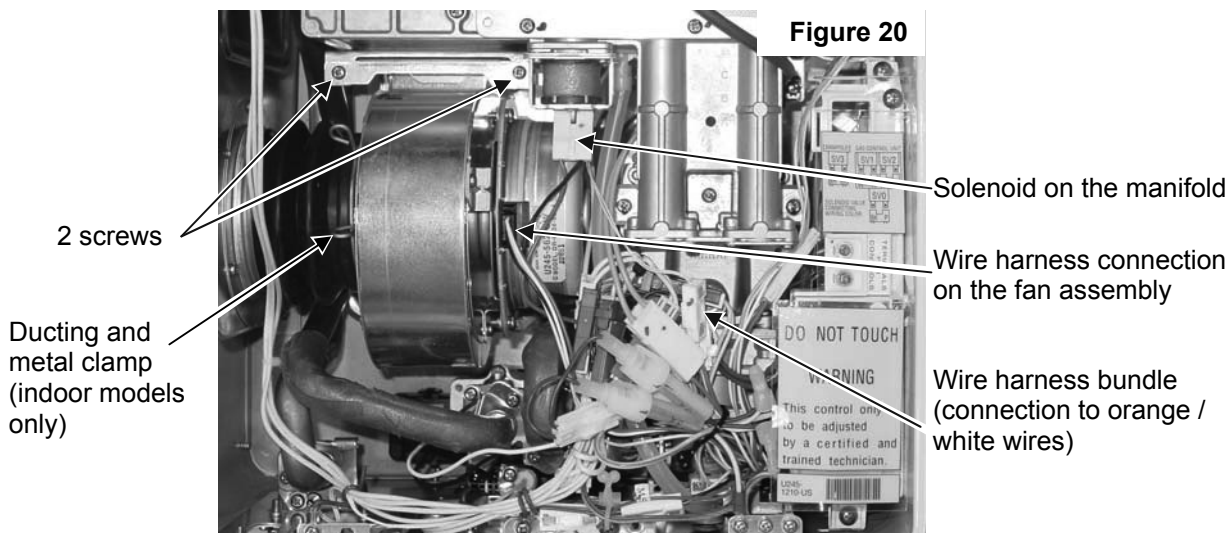

Remove the water flow assembly (Figure 21)

10. Remove 2 screws and 2 brackets at the water flow servo assembly. The brackets can be left on the water lines. Pull out the water lines.

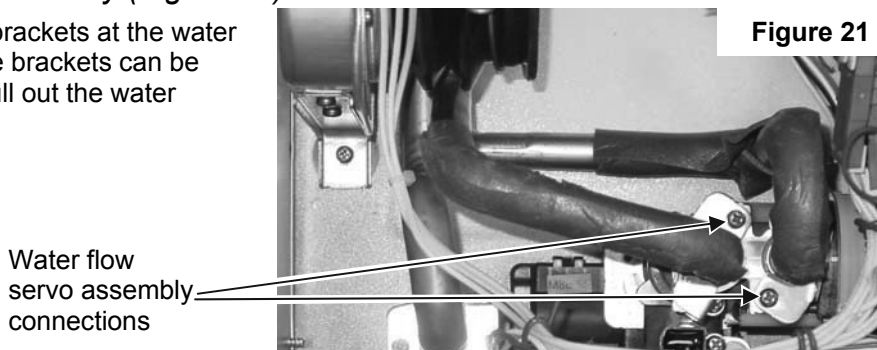

Component Replacement Instructions

505e, 505i
100/101 and 200/201 Series

Water Flow Control Assembly

11. Remove the 4 screws attaching the water inlet to the underneath side of the water heater.

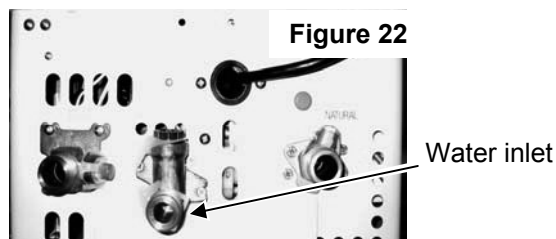

12. Disconnect the cable harnesses (Figure 23):

- water flow sensor harness (black/yellow/red wires)
- bypass servo assembly harness (white/red/yellow/orange/brown wires)
- water flow servo harness (red/blue/brown/yellow/gray or red/blue/brown/orange/yellow/gray wires)
- heating element

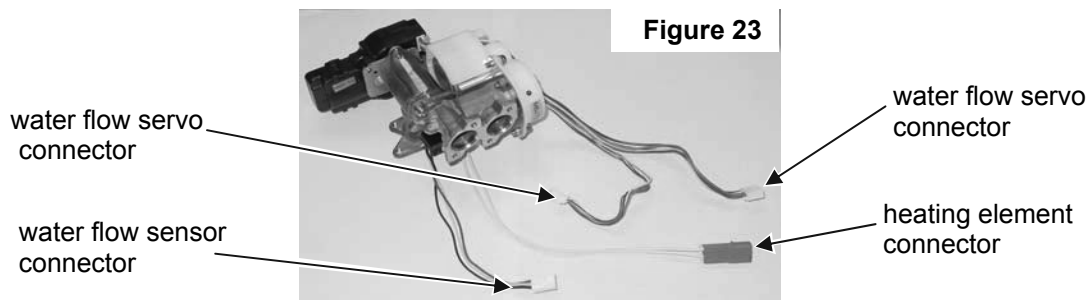

13. Pull out the water flow servo assembly and bypass servo assembly.

14. Remove 2 screws in order to separate the bypass servo assembly from the water flow servo assembly. (Figure 24)

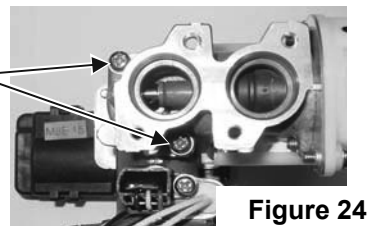

Assemble

15. Replace the O-ring (included in kit) between the water flow servo assembly and the bypass servo assembly. Attach the new water flow servo assembly to the bypass servo assembly with 2 screws.
16. Place inside the water heater and attach the cable harnesses.
17. Replace the O-ring on the water inlet (included in kit). Attach the water flow assembly to the water inlet using 4 screws. The 2 shorter screws can be installed first to connect the water flow assembly to the bottom of the compartment. Then install the 2 longer screws through the water inlet.
18. Replace the O-ring on the water lines (included in kit). Attach the two water lines to the bypass servo assembly with 1 screw each.
19. Install the fan assembly by inserting the tab on the fan assembly into the slot at the base of the heat exchanger and attaching with two screws.
20. On indoor models, push the ducting over the fan assembly inlet and secure with the metal pinch clamp.
21. Attach the wire harness to the fan assembly (white, yellow, black, red wires).
22. Install the front panel using 4 screws.
23. Turn on the water supply, power supply, and gas supply.
24. Open a hot water tap and ensure there are no leaks at the water heater.

Component Replacement Instructions

705e/o (ASME), 705i (ASME)

Water Flow Control Assembly

1. Turn off the gas supply.
2. Turn off the 120 V power supply.
3. Turn off the water supply. Drain all water from the appliance.
4. Remove four screws securing the front panel. Remove front panel.
5. Remove 2 screws and 2 brackets at the water flow servo assembly. Pull out the water lines. (Figure 25)
6. Remove the water flow sensor and the heating element. (Figure 25)
7. Remove the 4 screws attaching the water inlet to the underneath side of the water heater. (Figure 26)
8. Pull out the water flow servo assembly and bypass servo assembly. Remove the wire harness from the water servo valve. (Figure 27)
9. Remove 2 screws in order to separate the bypass servo assembly from the water flow servo assembly. (Figure 27)
10. Replace the O-ring (included in kit) between the water flow servo assembly and the bypass servo assembly. Attach the new water flow servo assembly to the bypass servo assembly with 2 screws.
11. Attach the wire harness to the water servo valve.
12. Place inside the water heater.
13. Attach the water flow assembly to the water inlet using 4 screws. The 2 shorter screws can be installed first to connect the water flow assembly to the bottom of the compartment. Install the 2 longer screws through the water inlet.
14. Insert the heating element and attach the water flow sensor.
15. Replace the O-ring on the water lines (included in kit). Attach the two water lines to the bypass servo assembly with 1 screw each.
16. Install the front panel using 4 screws.
17. Turn on the water supply, power supply, and gas supply.
18. Open a hot water tap and ensure there are no leaks at the water heater.

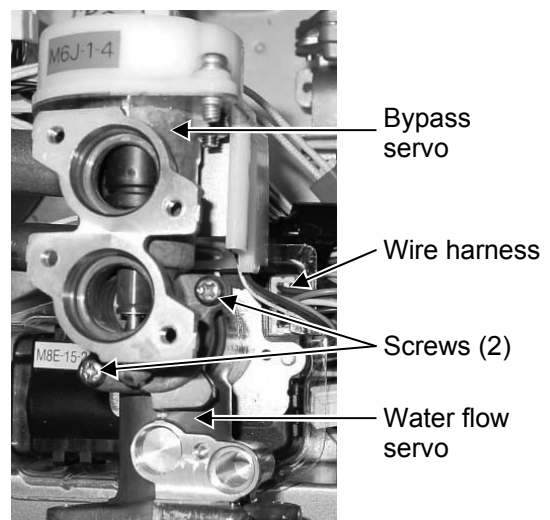
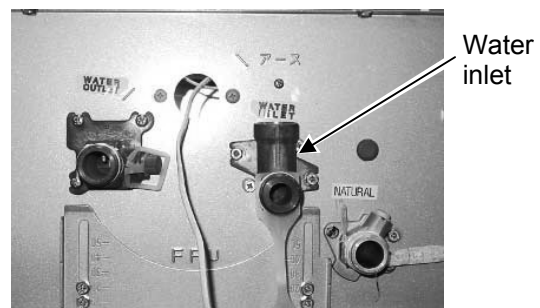
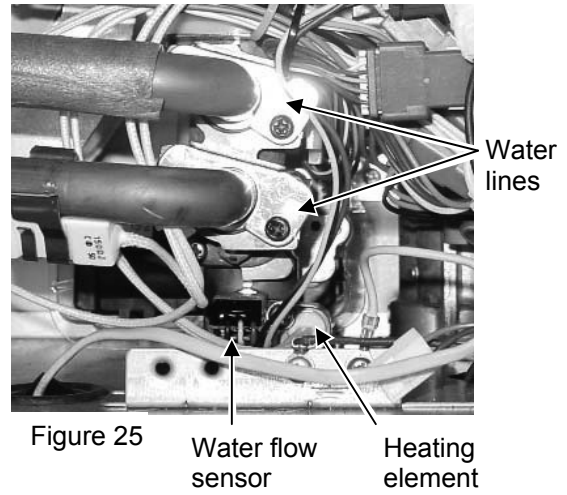

Component Replacement Instructions

305e

Heat Exchanger

1. Turn off the gas supply.
2. Turn off the 120 V power supply.
3. Turn off the water supply. Drain all water from the appliance.
4. Remove four screws securing the front panel. Remove front panel.

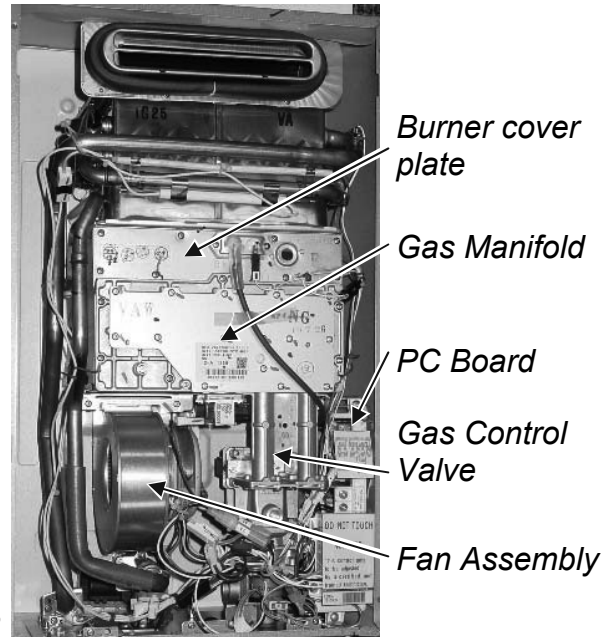

Figure 28

Remove Fan Assembly (Figure 29)

5. Disconnect wire harness at the fan assembly. Disconnect the air temperature thermistor (two white wires) at the connection with the white and orange wires within the wire bundle.
6. Pull out the harness attached to the solenoid on the manifold to make room to pull out the fan assembly.
7. Remove the 2 screws that attach the fan assembly to the bottom of the burner.
8. Pull out the fan assembly.

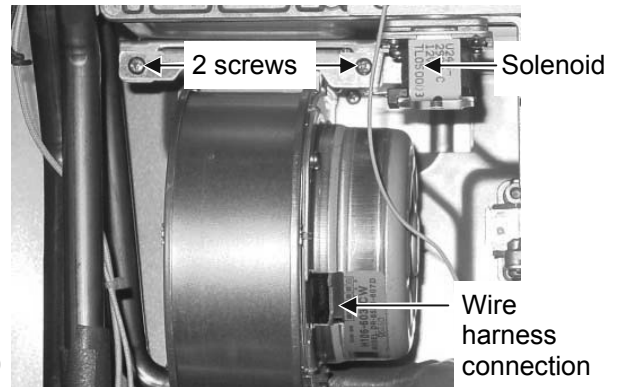

Figure 29

Disconnect Water Lines (Figure 30)

9. Remove 1 screw from the water outlet bracket. Remove the bracket by rotating and moving it up toward the bend in the tube where the diameter is smaller.
10. Remove 1 screw and 1 bracket at the water flow servo assembly.

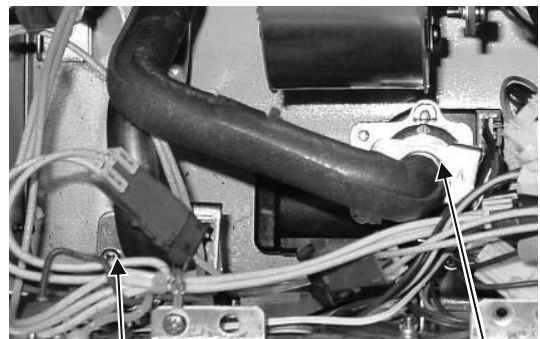

Figure 30

Water outlet connection

Water flow servo assembly connection

Component Replacement Instructions

Heat Exchanger

305e

Disconnect PC Board (Figure 31)

11. Remove 1 screw connecting the PC Board to the heat exchanger assembly.

Remove Gas Manifold (Figure 31)

12. Remove the 6 screws that attach the gas manifold to the combustion chamber (part of the heat exchanger assembly).
13. Remove the 3 screws that attach the gas manifold to the gas valve. These screws are machine screws and must be used at these locations.
14. Pull out the ignition line and remove the gas manifold.

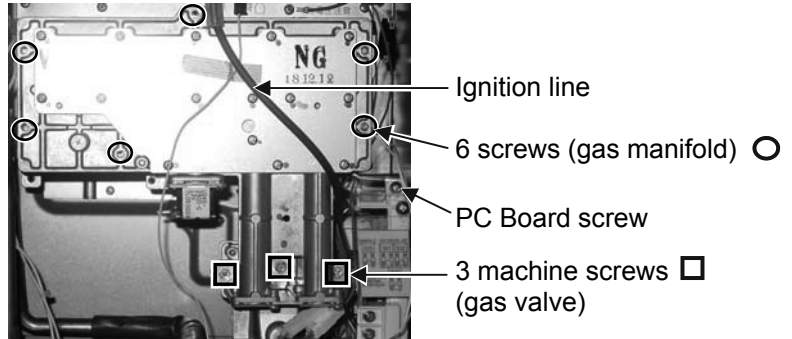

Figure 31

Remove Burner and Burner Cover Plate (Figure 32)

15. Remove the 8 screws attaching the burner cover plate to the combustion chamber. Move the cover plate to the side. It is not necessary to disconnect the wire harness from the burner cover plate.
16. Remove the 2 screws attaching the burner to the heat exchanger. Pull out the burner.
17. Unscrew the ignition line connection. (Figure 32)

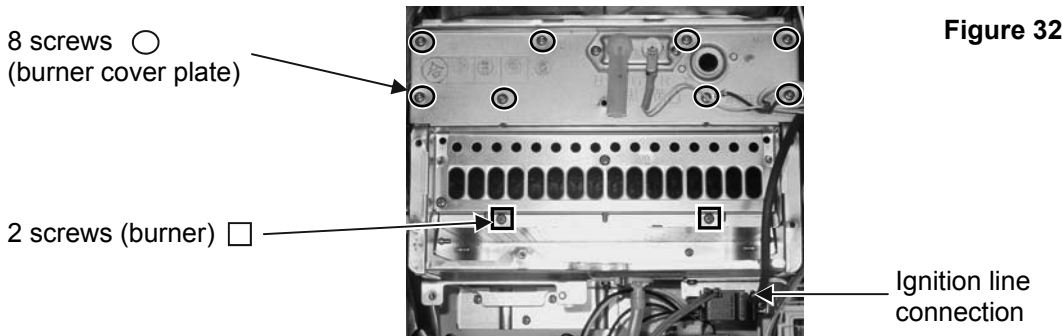

Figure 32

Disconnect Wire Harness Attachments and Screws Holding the Heat Exchanger

18. Remove the wire harness attachments - sensors, heating elements, fusible link brackets. Ensure that the small O-ring in the thermistor is removed.
19. Remove 3 screws behind the fan. (Figure 33)
20. Remove 2 screws above the exhaust. Pull assembly from the unit. (Figure 34)

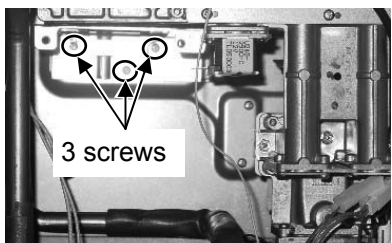

Figure 33

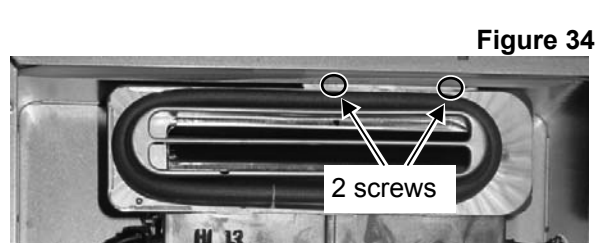

Figure 34

Component Replacement Instructions

Heat Exchanger

305e



WARNING

Failure to correctly assemble the components according to these instructions could result in a gas leak or explosion.

Installation

21. Install the largest O-ring (included in kit) over the water outlet tube and the two smaller O-rings (included in kit) over the bypass servo tubes. (Figure 30)
22. Remove any other attached items and install on the new heat exchanger.
23. Install the new heat exchanger using 2 screws above the exhaust and 3 screws behind the fan. (Figures 33, 34)

Connect Pressure Tube and Wire Harness Attachments

24. Connect wire harness attachments.
25. Connect the pressure tube.
26. Attach the ignition line connection with 1 screw.

Install Burner and Burner Cover Plate (Figure 32)

27. Replace the combustion chamber packing (included in kit) removing any residue from old packing. Insert the burner and place the burner cover plate into position. Attach the burner cover plate first with 8 screws and then attach the burner with 2 screws.

Install Gas Manifold and Connect PC Board

28. Make sure that the two black packings (Figure 35) are intact on the gas control assembly. Attach the gas manifold with 3 machine screws at the gas control assembly. Replace the lower and upper packings (included in kit) for the manifold plate removing any residue.
29. Attach the gas manifold with 6 screws at heat exchanger.
30. Attach the ignition line at the burner cover plate.
31. Attach the PC Board to the heat exchanger with 1 screw.

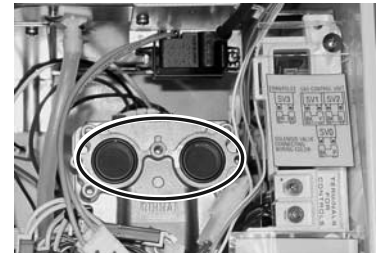

Figure 35

Connect Water Lines (Figure 30)

32. Attach the water outlet line and bracket with 1 screw.
33. Attach the line to the water flow servo assembly with 1 screw and 1 bracket.

Install Fan Assembly (Figure 29)

34. Install the fan assembly by inserting the tab on the fan assembly into the slot at the base of the heat exchanger and attaching with two screws.
35. Attach the wire harness to the solenoid on the gas manifold (brown, black wires).
36. Attach the wire harness to the fan assembly (white, yellow, black, red wires).
37. Attach the air temperature thermistor (white, white wires) to the wire harness.
38. Install the front panel using 4 screws.
39. Turn on the water supply, power supply, and gas supply.
40. Check for gas leaks.

Component Replacement Instructions

505e/o

Heat Exchanger

1. Turn off the gas supply.
2. Turn off the 120 V power supply.
3. Turn off the water supply. Drain all water from the appliance.
4. Remove four screws securing the front panel. Remove front panel.

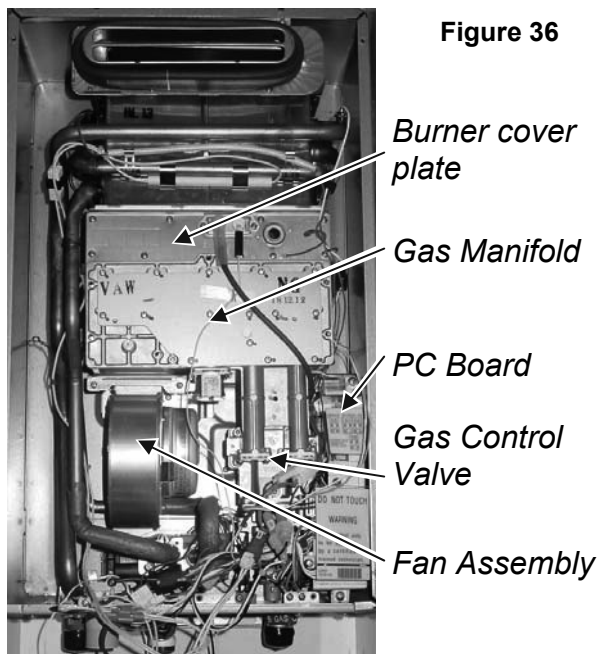

Figure 36

Burner cover plate

Gas Manifold

PC Board

Gas Control Valve

Fan Assembly

Remove Fan Assembly (Figure 37)

5. Disconnect wire harness at the fan assembly. Disconnect the air temperature thermistor (two white wires) at the connection with the white and orange wires within the wire bundle.
6. Pull out the harness attached to the solenoid on the manifold to make room to pull out the fan assembly.
7. Remove the 2 screws that attach the fan assembly to the bottom of the burner.
8. Pull out the fan assembly.

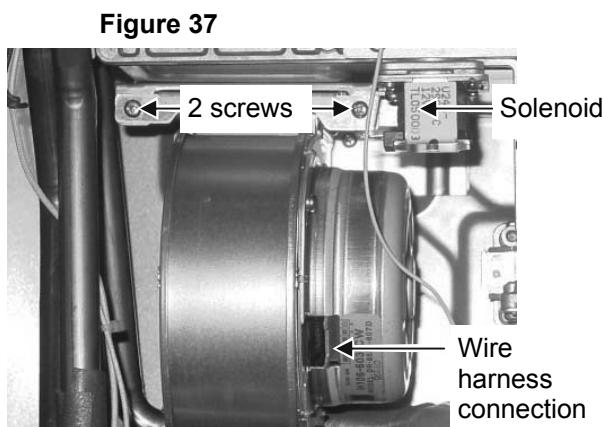

Figure 37

2 screws

Solenoid

Wire harness connection

Disconnect Water Lines (Figure 38)

9. Remove 1 screw from the water outlet bracket. Remove the bracket by rotating and moving it up toward the bend in the tube where the diameter is smaller.
10. Remove 2 screws and 2 brackets at the bypass servo assembly.

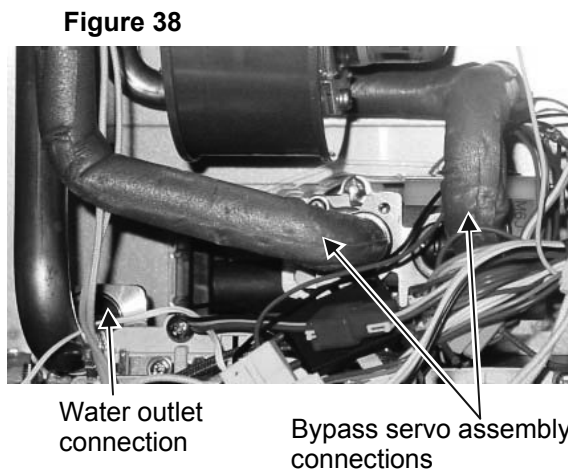

Figure 38

Water outlet connection

Bypass servo assembly connections

Component Replacement Instructions

Heat Exchanger

505e/o

Disconnect PC Board (Figure 39)

11. Remove 1 screw connecting the PC Board to the heat exchanger assembly.

Remove Gas Manifold (Figure 39)

12. Remove the 6 screws that attach the gas manifold to the combustion chamber (part of the heat exchanger assembly).

13. Remove the 3 screws that attach the gas manifold to the gas valve. These screws are machine screws and must be used at these locations.

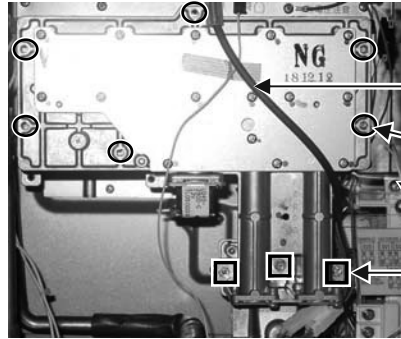

Figure 39

Ignition line

6 screws (gas manifold) ○

PC Board screw

3 machine screws □
(gas valve)

Remove Burner and Burner Cover Plate (Figure 40)

14. Pull out the ignition line and remove the gas manifold.

15. Remove the 8 screws attaching the burner cover plate to the combustion chamber. Move the cover plate to the side. It is not necessary to disconnect the wire harness from the burner cover plate.

16. Remove the 2 screws attaching the burner to the heat exchanger. Pull out the burner.

8 screws ○
(burner cover plate)

2 screws (burner) □

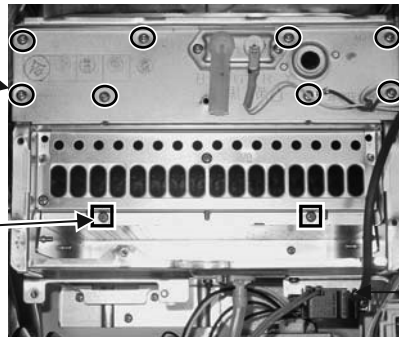

Figure 40

Ignition line
connection

Disconnect Wire Harness Attachments and Screws Holding the Heat Exchanger

17. Unscrew the ignition line connection. (Figure 40)

18. Remove the wire harness attachments - sensors, heating elements, fusible link brackets. Ensure that the small O-ring in the thermistor is removed.

19. Remove 3 screws behind the fan. (Figure 41)

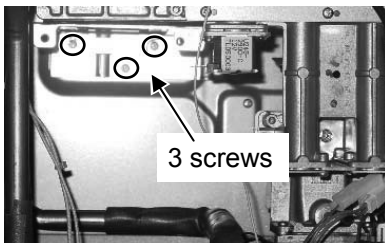

Figure 41

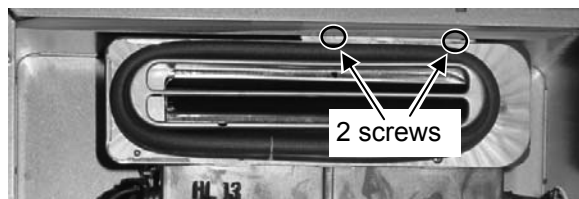

Figure 42

Component Replacement Instructions

505e/o

Heat Exchanger



WARNING

Failure to correctly assemble the components according to these instructions could result in a gas leak or explosion.

Installation

20. Remove 2 screws above the exhaust. Pull assembly from the unit. (Figure 42)
21. Install the largest O-ring (included in kit) over the water outlet tube and the two smaller O-rings (included in kit) over the bypass servo tubes. (Figure 38)
22. Remove any other attached items and install on the new heat exchanger.

Connect Pressure Tube and Wire Harness Attachments

23. Install the new heat exchanger using 2 screws above the exhaust and 3 screws behind the fan. (Figures 41, 42)

Install Burner and Burner Cover Plate (Figure 40)

24. Connect wire harness attachments.
25. Connect the pressure tube. Attach the ignition line connection with 1 screw.

Install Gas Manifold and Connect PC Board

26. Replace the combustion chamber packing (included in kit) removing any residue from old packing. Insert the burner and place the burner cover plate into position. Attach the burner cover plate first with 8 screws and then attach the burner with 2 screws.
27. Make sure that the two black packings (Figure 43) are intact on the gas control assembly. Attach the gas manifold with 3 machine screws at the gas control assembly. Replace the lower and upper packings (included in kit) for the manifold plate removing any residue.

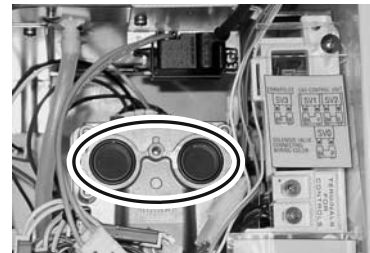

Figure 43

Connect Water Lines (Figure 38)

28. Attach the gas manifold with 6 screws at heat exchanger.
29. Attach the ignition line at the burner cover plate.

Install Fan Assembly (Figure 37)

30. Attach the PC Board to the heat exchanger with 1 screw.
31. Attach the water outlet line and bracket with 1 screw.
32. Attach the two lines to the bypass servo assembly with 1 screw and 1 bracket for each line.
33. Install the fan assembly by inserting the tab on the fan assembly into the slot at the base of the heat exchanger and attaching with two screws.
34. Attach the wire harness to the solenoid on the gas manifold (brown, black wires).
35. Attach the wire harness to the fan assembly (white, yellow, black, red wires).

Component Replacement Instructions

305i

Heat Exchanger

1. Turn off the gas supply.
2. Turn off the 120 V power supply.
3. Turn off the water supply. Drain all water from the appliance.
4. Remove four screws securing the front panel. Remove front panel.

Remove Fan Assembly (Figure 45)

5. Disconnect wire harness at the fan assembly. Disconnect the air temperature thermistor (two white wires) at the connection with the white and orange wires within the wire bundle.
6. Pull out the harness attached to the solenoid on the manifold to make room to pull out the fan assembly.
7. Remove the 2 screws that attach the fan assembly to the bottom of the burner.
8. Loosen the ducting from the fan assembly by pinching open the metal clamp.
9. Pull out the fan assembly.

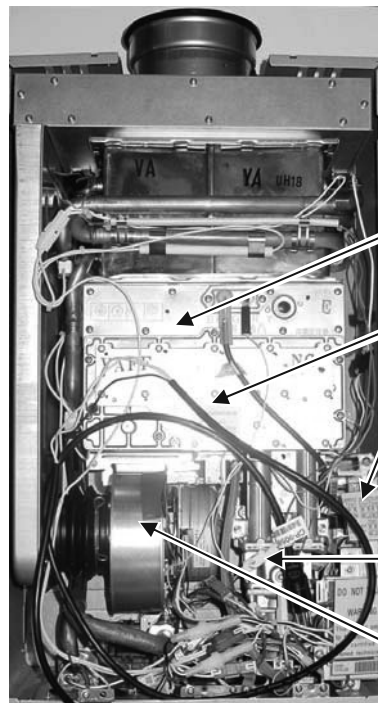

Figure 44

Burner cover plate

Gas Manifold

PC Board

Gas Control Valve

Fan Assembly

Disconnect Water Lines and PC Board (Figure 45)

10. Remove 1 screw from the water outlet bracket. Remove the bracket by rotating and moving it up toward the bend in the tube where the diameter is smaller.
11. Remove the screw and bracket at the water flow servo assembly.
12. Remove 1 screw connecting the PC Board to the heat exchanger assembly.

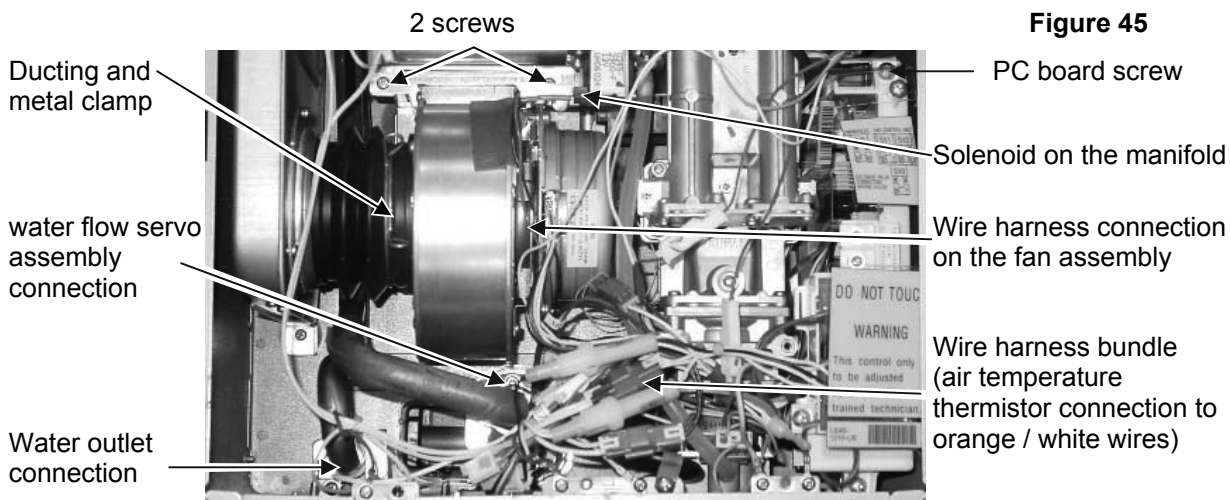

Figure 45

2 screws

Ducting and metal clamp

water flow servo assembly connection

Water outlet connection

PC board screw

Solenoid on the manifold

Wire harness connection on the fan assembly

Wire harness bundle (air temperature thermistor connection to orange / white wires)

Component Replacement Instructions

Heat Exchanger

305i

Remove Gas Manifold (Figure 46)

13. Remove the 6 screws that attach the gas manifold to the combustion chamber (part of the heat exchanger assembly).
14. Remove the 3 screws that attach the gas manifold to the gas valve. These screws are machine screws and must be used at these locations.
15. Pull out the ignition line and remove the gas manifold.

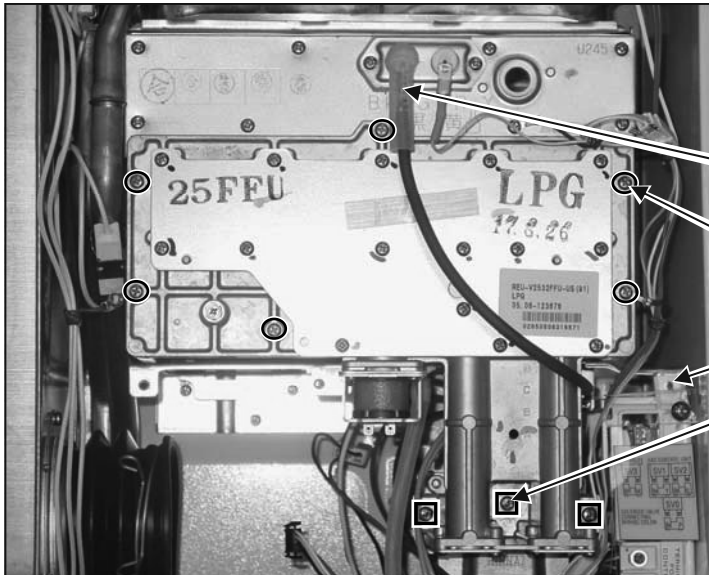

Figure 46

- Ignition line
- 6 screws (gas manifold) ○
- PC Board screw
- 3 machine screws (gas valve) □

Remove Burner and Burner Cover Plate (Figure 47)

16. Remove the 8 screws attaching the burner cover plate to the combustion chamber. Move the cover plate to the side. It is not necessary to disconnect the wire harness from the burner cover plate.
17. Remove the 2 screws attaching the burner to the heat exchanger. Pull out the burner.
18. Disconnect the pressure tube from the heat exchanger and unscrew the ignition line connection.

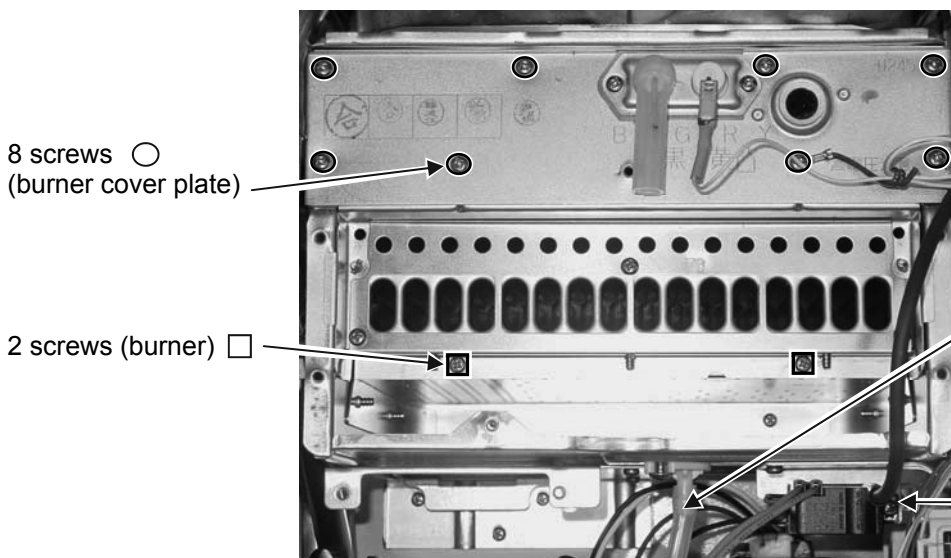

Figure 47

- 8 screws (burner cover plate) ○
- 2 screws (burner) □
- Pressure tube
- Ignition line connection

Component Replacement Instructions

305i

Heat Exchanger

Disconnect Wire Harness Attachments

19. Remove the wire harness attachments - sensors, heating elements, fusible link brackets. Ensure that the small O-ring in the thermistor is removed.

Remove Heat Exchanger and Air Intake/Exhaust

20. Remove 8 screws connecting the assembly to the water heater casing assembly. (Figures 48, 49)

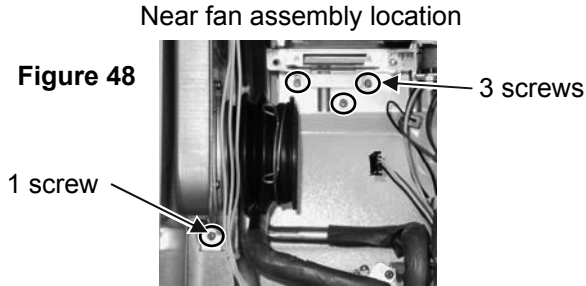

Separate the Heat Exchanger from the Air Intake/Exhaust

21. Pull out the assembly. Remove 3 brackets on the side and back holding the fusible link.

22. Remove the 9 screws at the cover plate over the air intake passage. (Figure 50)

23. Remove the 4 screws attaching the heat exchanger to the air intake/exhaust assembly. (Figure 51)

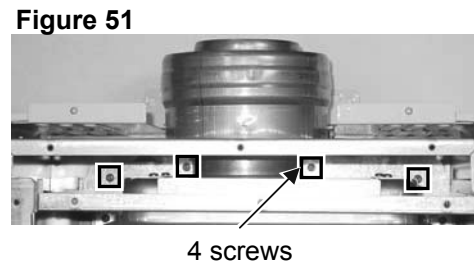
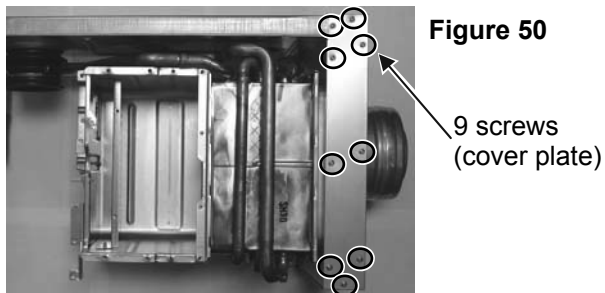

24. Pull apart the heat exchanger and air intake/exhaust assembly. (Figure 52)

25. Remove 4 screws attaching the bracket on top of the heat exchanger. Pull off the bracket. (Figure 53)

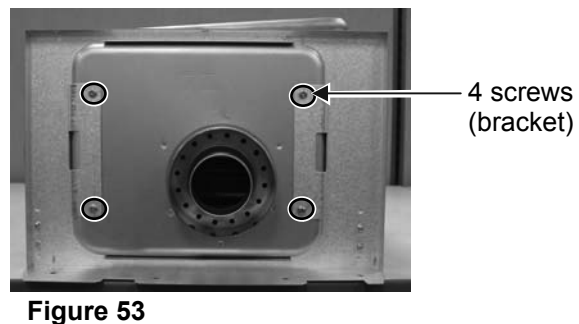
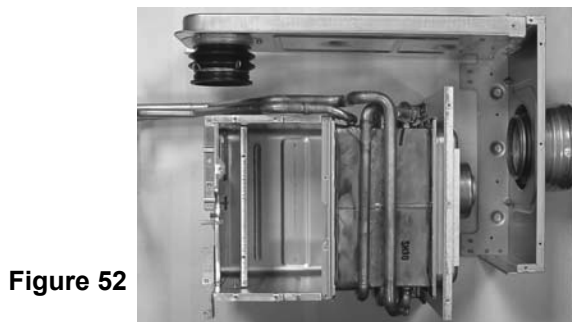

WARNING

Failure to correctly assemble the components according to these instructions could result in a gas leak or explosion.

Component Replacement Instructions

305i

Heat Exchanger

Install Packings and Bracket

26. Install the O-ring (included in kit) over the water outlet tube and the O-ring (included in kit) over the water flow servo tube. (Figure 45)
27. Install the bracket over the replacement heat exchanger. Push evenly on both sides of the bracket. Attach with four screws. (Figure 54)

Combine the Heat Exchanger and the Air Intake/Exhaust Assembly

28. Push the heat exchanger into the air intake/exhaust assembly. Attach with four screws. (Figure 51)
29. Attach the cover plate over the air intake passage with 9 screws. (Figure 51)

Install Heat Exchanger and Air Intake/Exhaust Assembly (Figures 48, 49)

30. Attach the fusible link to the back (2 brackets) and side (1 bracket). Slide the assembly into the casing assembly and attach with 8 screws starting at the top of the water heater.

Connect Pressure Tube and Wire Harness Attachments

31. Connect wire harness attachments.
32. Connect the pressure tube. Attach the ignition line connection with 1 screw. (Figure 47)

Install Burner and Burner Cover Plate (Figure 47)

33. Replace the combustion chamber packing (included in kit) removing any residue from old packing. Insert the burner and place the burner cover plate into position. Attach the burner cover plate first with 8 screws and then attach the burner with 2 screws.

Install Gas Manifold and Connect PC Board

34. Make sure that the two black packings (Figure 54) are intact on the gas control assembly. Attach the gas manifold with 3 machine screws at the gas control assembly. Replace the lower and upper packings (included in kit) for the manifold plate removing any residue.
35. Attach the gas manifold with 6 screws at heat exchanger.
36. Attach the ignition line at the burner cover plate.

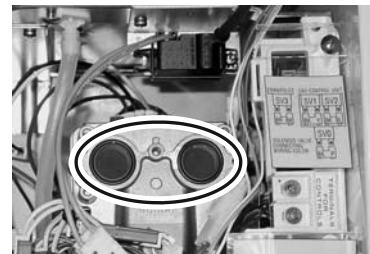

Figure 54

Connect Water Lines (Figure 45)

37. Attach the PC Board to the heat exchanger with 1 screw.
38. Attach the water outlet line and bracket with 1 screw.
39. Attach the two lines to the bypass servo assembly with 1 screw and 1 bracket for each line.

Install Fan Assembly (Figure 45)

40. Install the fan assembly by inserting the tab on the fan assembly into the slot at the base of the heat exchanger and attaching with two screws.
41. Push the ducting over the fan assembly exit and secure with the metal pinch clamp.
42. Attach the wire harness to the solenoid on the gas manifold (brown, black wires).
43. Attach the wire harness to the fan assembly (white, yellow, black, red wires).
44. Attach the air temperature thermistor (white, white wires) to the wire harness.
45. Install the front panel using 4 screws.
46. Turn on the water supply, power supply, and gas supply.
47. Check for gas leaks.

Component Replacement Instructions

505i

Heat Exchanger

1. Turn off the gas supply.
2. Turn off the 120 V power supply.
3. Turn off the water supply. Drain all water from the appliance.
4. Remove four screws securing the front panel. Remove front panel.

Remove Fan Assembly (Figure 56)

5. Disconnect wire harness at the fan assembly. Disconnect the air temperature thermistor (two white wires) at the connection with the white and orange wires within the wire bundle.
6. Pull out the harness attached to the solenoid on the manifold to make room to pull out the fan assembly.
7. Remove the 2 screws that attach the fan assembly to the bottom of the burner.
8. Loosen the ducting from the fan assembly by pinching open the metal clamp.
9. Pull out the fan assembly.

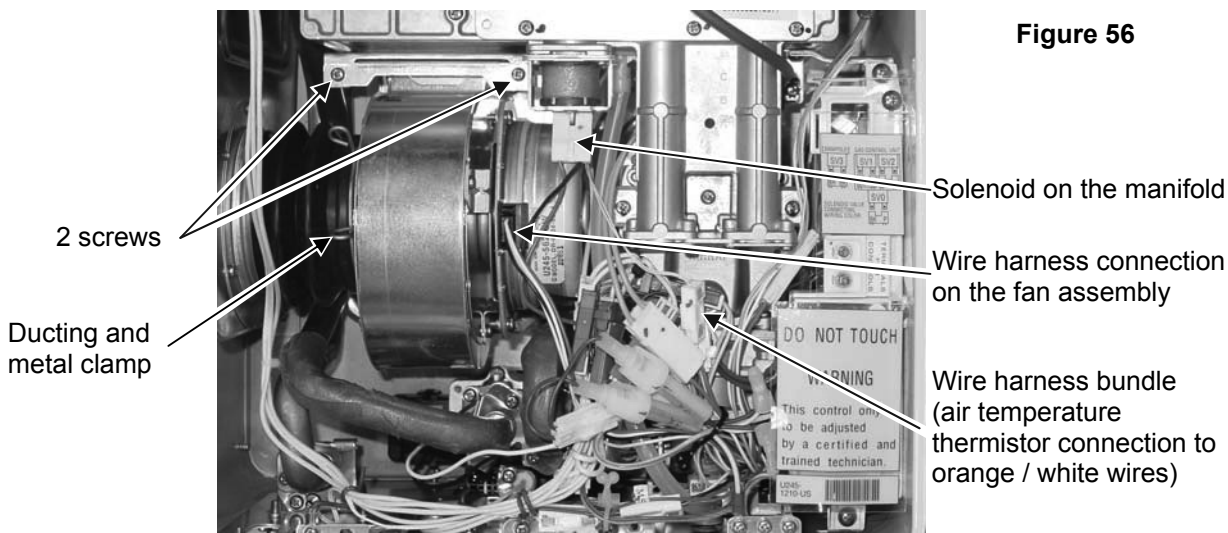
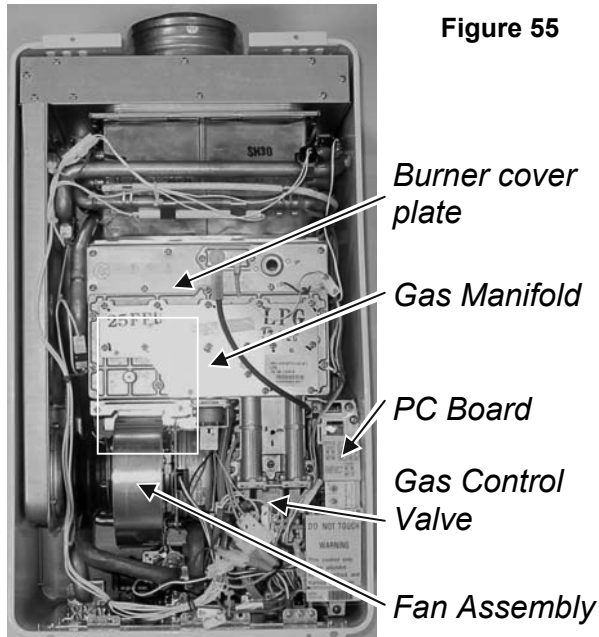

Component Replacement Instructions

505i

Heat Exchanger

Disconnect Water Lines (Figure 57)

10. Remove 1 screw from the water outlet bracket. Remove the bracket by rotating and moving it up toward the bend in the tube where the diameter is smaller.
11. Remove 2 screws and 2 brackets at the bypass servo assembly.

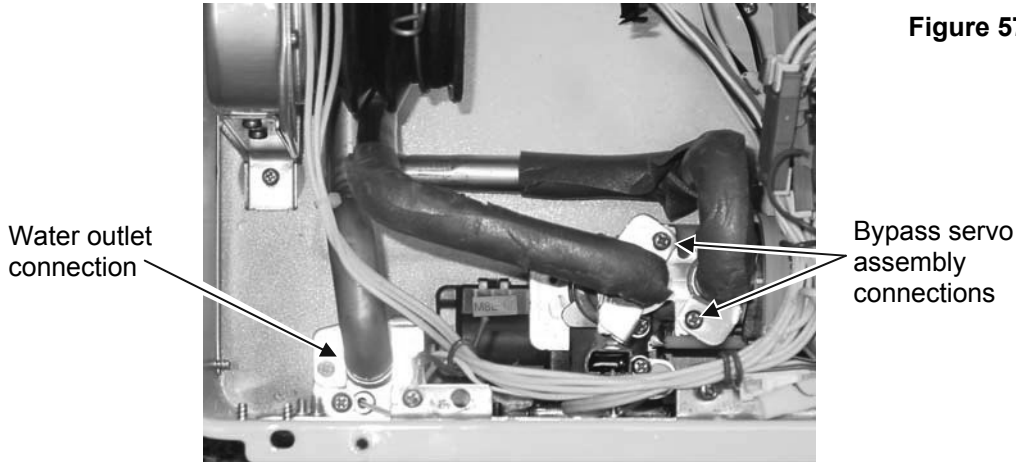

Figure 57

Disconnect PC Board (Figure 58)

12. Remove 1 screw connecting the PC Board to the heat exchanger assembly.

Remove Gas Manifold (Figure 58)

13. Remove the 6 screws that attach the gas manifold to the combustion chamber (part of the heat exchanger assembly).
14. Remove the 3 screws that attach the gas manifold to the gas valve. These screws are machine screws and must be used at these locations.
15. Pull out the ignition line and remove the gas manifold.

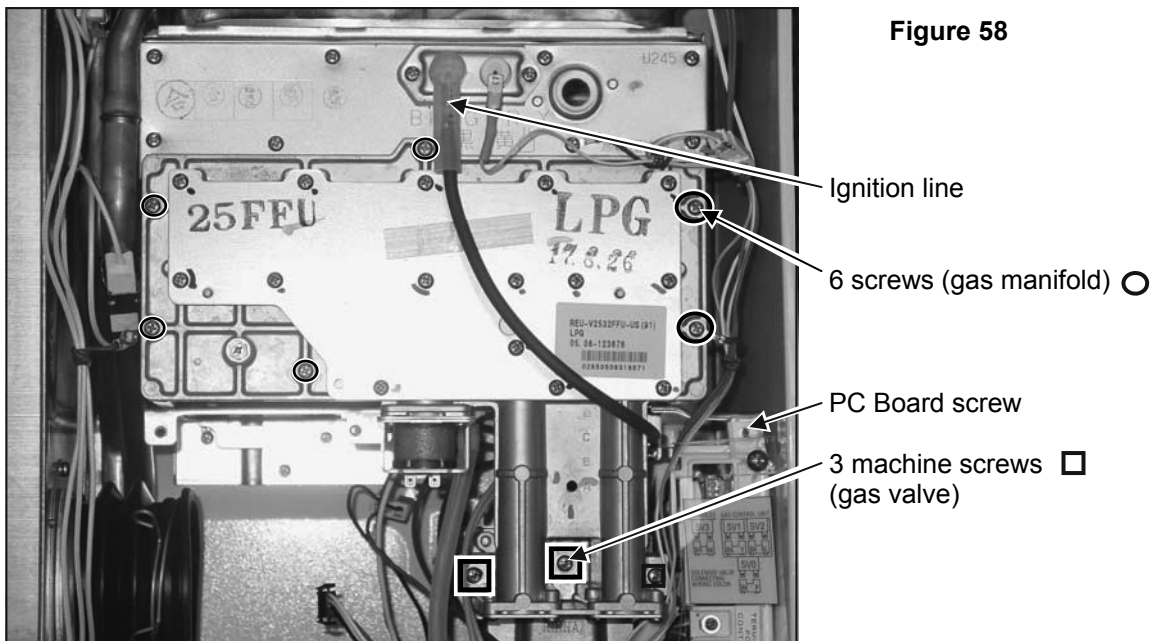

Figure 58

Component Replacement Instructions

505i

Heat Exchanger

Remove Burner and Burner Cover Plate (Figure 59)

16. Remove the 8 screws attaching the burner cover plate to the combustion chamber. Move the cover plate to the side. It is not necessary to disconnect the wire harness from the burner cover plate.
17. Remove the 2 screws attaching the burner to the heat exchanger. Pull out the burner.

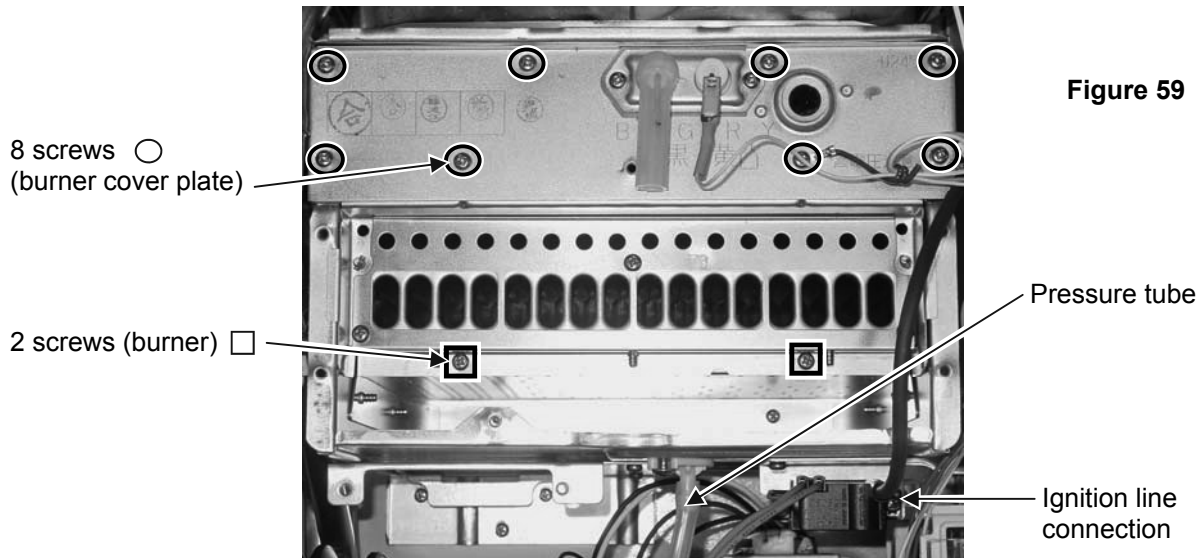

Disconnect Gas Line and Wire Harness Attachments

18. Disconnect the pressure tube from the heat exchanger and unscrew the ignition line connection. (Figure 59)
19. Remove the wire harness attachments - sensors, heating elements, fusible link brackets. Ensure that the small O-ring in the thermistor is removed. (Figure 60)

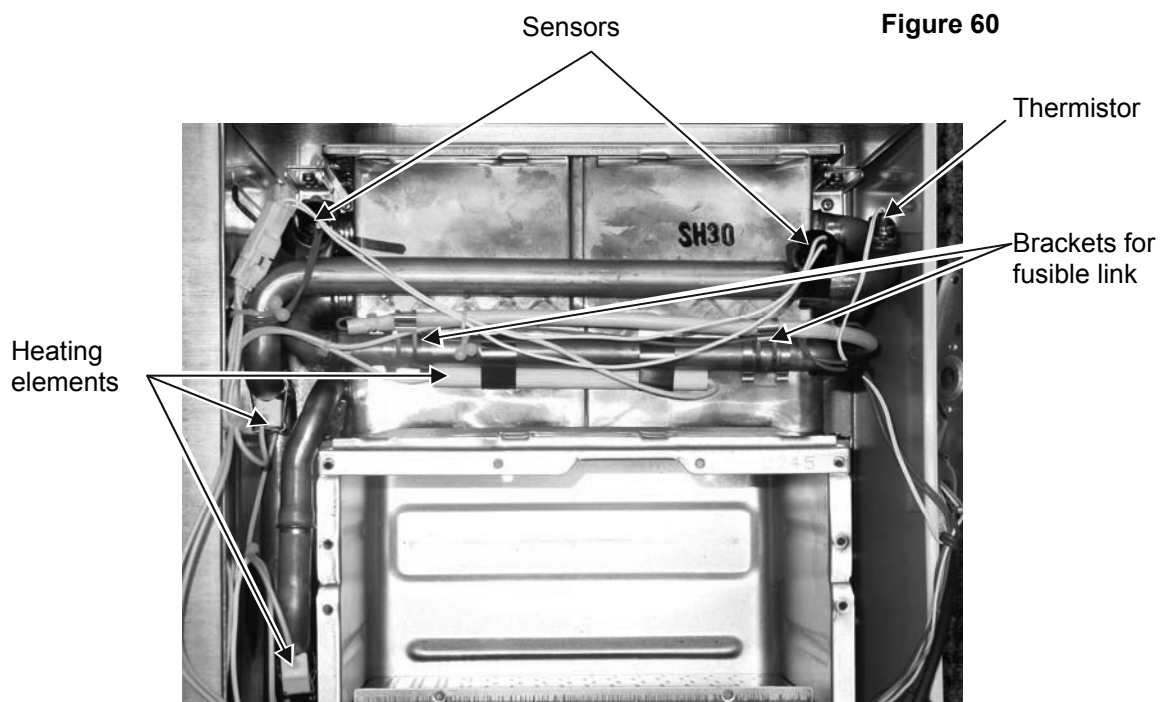

Component Replacement Instructions

505i

Heat Exchanger

Remove Heat Exchanger and Air Intake/Exhaust

20. Remove 8 screws connecting the assembly to the water heater casing assembly. (Figures 61, 62)

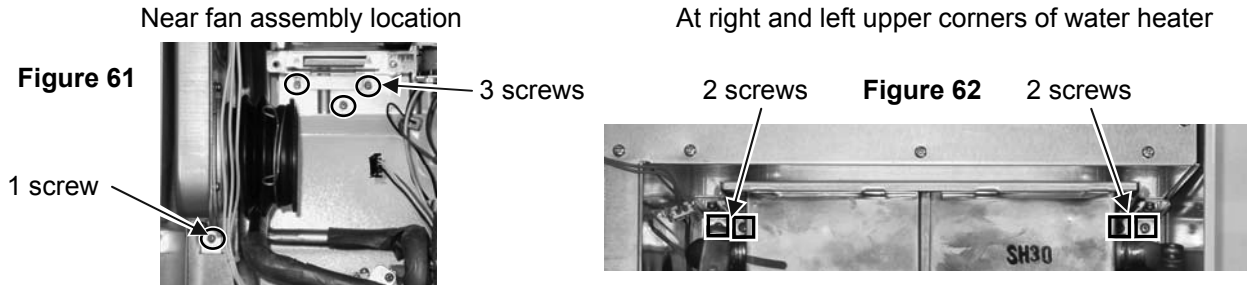

Separate the Heat Exchanger from the Air Intake/Exhaust

21. Pull out the assembly. Remove 3 brackets on the side and back holding the fusible link.

22. Remove the 9 screws at the cover plate over the air intake passage. (Figure 63)

23. Remove the 4 screws attaching the heat exchanger to the air intake/exhaust assembly. (Figure 64)

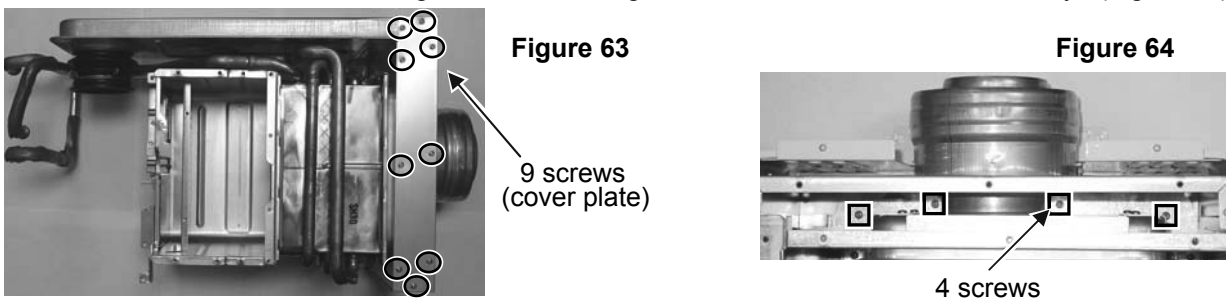

24. Pull apart the heat exchanger and air intake/exhaust assembly. (Figure 65)

25. Remove 4 screws attaching the bracket on top of the heat exchanger. Pull off the bracket. (Figure 66)

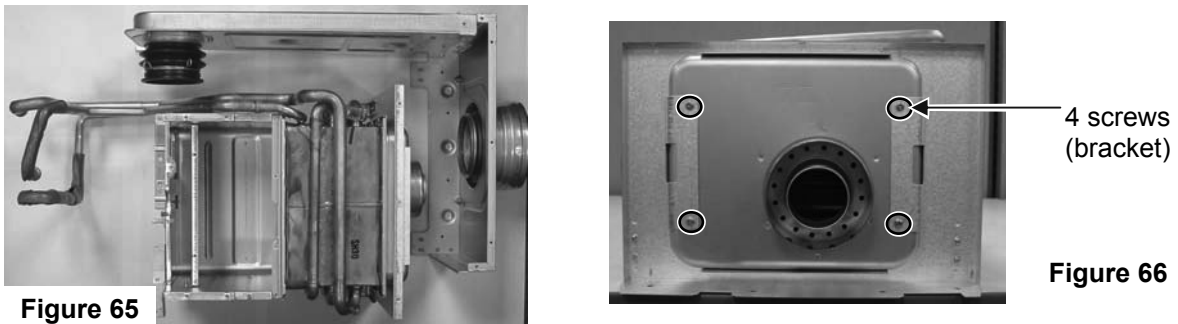

WARNING Failure to correctly assemble the components according to these instructions could result in a gas leak or explosion.

Install Packings and Bracket

26. Install the largest O-ring (included in kit) over the water outlet tube and the two smaller O-rings (included in kit) over the bypass servo tubes. (Figure 57)

27. Install the bracket over the replacement heat exchanger. Push evenly on both sides of the bracket. Attach with four screws. (Figure 66)

Component Replacement Instructions

505i

Heat Exchanger

Combine the Heat Exchanger and the Air Intake/Exhaust

28. Push the heat exchanger into the air intake/exhaust assembly. Attach with four screws. (Figure 64)
29. Attach the cover plate over the air intake passage with 9 screws. (Figure 63)

Install Heat Exchanger and Air Intake/Exhaust Assembly (Figures 61, 62)

30. Attach the fusible link to the back (2 brackets) and side (1 bracket). Slide the assembly into the casing assembly and attach with 8 screws starting at the top of the water heater.

Connect Pressure Tube and Wire Harness Attachments

31. Connect wire harness attachments. (Figure 60)
32. Connect the pressure tube.
33. Attach the ignition line connection with 1 screw. (Figure 59)

Install Burner and Burner Cover Plate (Figure 59)

34. Replace the combustion chamber packing (included in kit) removing any residue from old packing. Insert the burner and place the burner cover plate into position. Attach the burner cover plate first with 8 screws and then attach the burner with 2 screws.

Install Gas Manifold and Connect PC Board

35. Make sure that the two black packings (Figure 67) are intact on the gas control assembly. Attach the gas manifold with 3 machine screws at the gas control assembly. Replace the lower and upper packings (included in kit) for the manifold plate removing any residue.
36. Attach the gas manifold with 6 screws at heat exchanger.
37. Attach the ignition line at the burner cover plate.

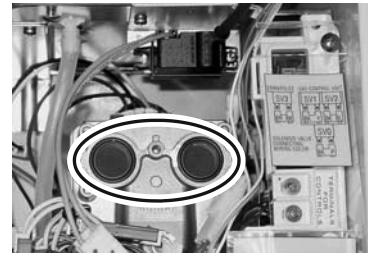

Figure 67

Connect Water Lines (Figure 57)

38. Attach the PC Board to the heat exchanger with 1 screw.
39. Attach the water outlet line and bracket with 1 screw.
40. Attach the two lines to the bypass servo assembly with 1 screw and 1 bracket for each line.

Install Fan Assembly (Figure 56)

41. Install the fan assembly by inserting the tab on the fan assembly into the slot at the base of the heat exchanger and attaching with two screws.
42. Push the ducting over the fan assembly exit and secure with the metal pinch clamp.
43. Attach the wire harness to the solenoid on the gas manifold (brown, black wires).
44. Attach the wire harness to the fan assembly (white, yellow, black, red wires).
45. Attach the air temperature thermistor (white, white wires) to the wire harness.
46. Install the front panel using 4 screws.
47. Turn on the water supply, power supply, and gas supply.
48. Check for gas leaks.

Component Replacement Instructions

705e/o (ASME)

Heat Exchanger

1. Turn off the gas supply.
2. Turn off the 120 V power supply.
3. Turn off the water supply. Drain all water from the appliance.
4. Remove four screws securing the front panel. Remove front panel.
5. Disconnect wire harness at the fan assembly, the electrical connections to the 3 solenoid valves, and the ignition line.
6. Remove 3 screws and brackets securing the water line connections. (Figure 68)
7. Remove the 5 screws that attach the gas manifold to the combustion chamber (part of the heat exchanger assembly). (Figure 68)
8. Remove the 2 screws that attach the gas manifold to the gas valve. These screws are machine screws and must be used at these locations. (Figure 68)
9. Pull out the gas manifold and remove the connector at the ignitor at the left side of the gas manifold.
10. Remove the 9 screws attaching the burner cover plate to the combustion chamber. (Figure 69)
11. Remove the 2 screws attaching the burner to the heat exchanger. Pull out the burner. (Figure 69)
12. Remove the wire harness attachments - sensors, heating elements, fusible link brackets. Ensure that the small O-ring at the thermistor is removed.
13. Remove the 4 screws connecting the heat exchanger to the casing. (Figure 70)
14. Pull out the assembly. Remove the brackets on the side and back holding the fusible link. Slide off the fusible link.

5 screws ○
(gas manifold)

2 machine screws □
(gas valve)

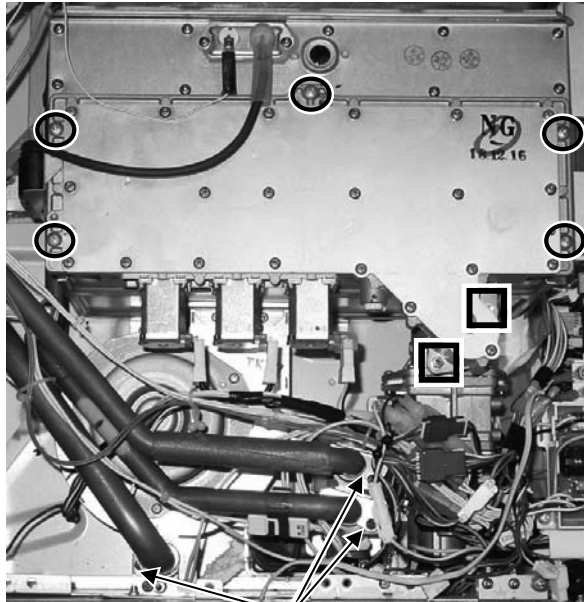

Figure 68

Water line connections



Figure 69 9 screws ○
(burner cover plate)

2 screws □
(burner)

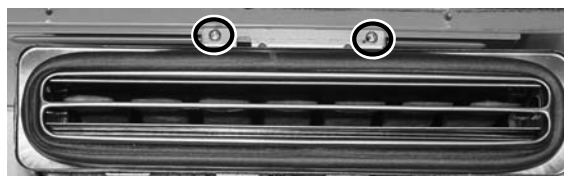

Top screws

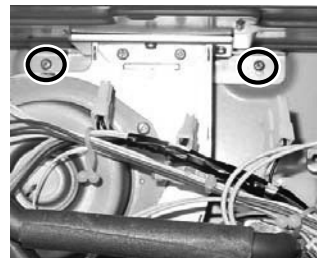

Figure 70 Bottom screws

Component Replacement Instructions

705e/o (ASME)

Heat Exchanger

15. Remove the fan assembly (4 screws) and install it on the new heat exchanger. (Figure 71)
16. Remove the flue outlet (6 screws) and install it on the new heat exchanger. (Figure 72)
17. Install the largest O-ring (included in kit) over the water outlet tube and the two smaller O-rings (included in kit) over the water inlet tubes. (Figure 71)
18. Slide the fusible link between the water outlet and inlet tubes and onto the new heat exchanger. (Figure 71)
19. Attach brackets at the back and side holding the fusible link.
20. Install the 4 screws at the top and bottom of the heat exchanger to the casing. (Figure 70)
21. Insert the burner and place the burner cover plate into position. Attach the burner cover plate first with 9 screws and then attach the burner with 2 screws. (Figure 69)
22. Replace the electrode gasket. (Figure 73)
23. Make sure that the black gasket (Figure 74) is intact on the gas control assembly. Replace the lower and upper gaskets (included in kit) for the manifold plate removing any residue. (Figure 75)
24. Attach the electrical connector to the ignitor on the manifold and attach the gas manifold with 2 machine screws at the gas control assembly. (Figure 68)
25. Attach the gas manifold with 5 screws at heat exchanger. (Figure 68)
26. Connect wire harness attachments.
27. Attach the ignition line at the burner cover plate.
28. Attach the 3 electrical connectors to the solenoid valves.
29. Attach the wire harness to the fan assembly (white, yellow, black, red wires).
30. Attach the brackets to the water line connections. (Figure 68)
31. Install the front panel using 4 screws. Turn on the water supply, power supply, and gas supply. Check for gas leaks.

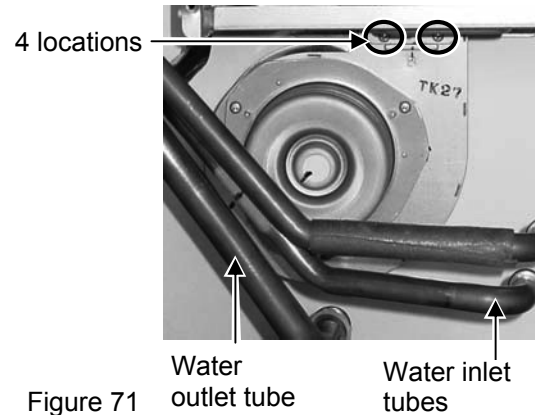

Figure 71



Figure 72

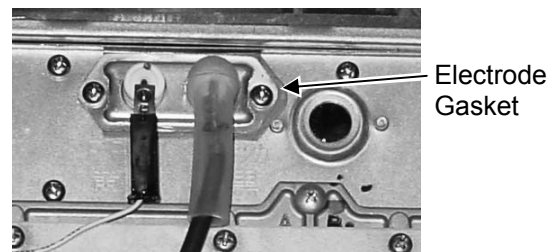

Figure 73

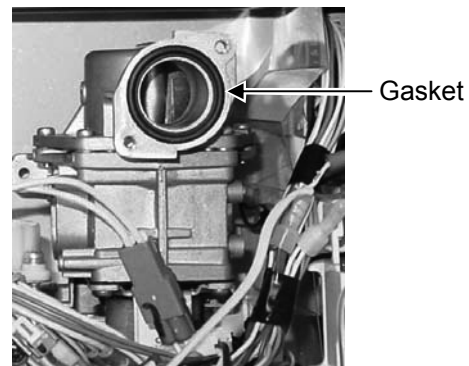

Figure 74

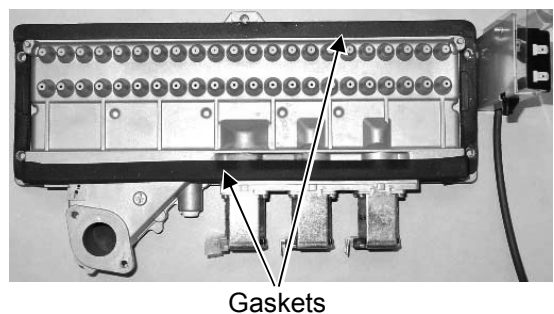

Figure 75

Component Replacement Instructions

Heat Exchanger

705i (ASME)

1. Turn off the gas supply.
2. Turn off the 120 V power supply.
3. Turn off the water supply. Drain all water from the appliance.
4. Remove four screws securing the front panel. Remove front panel.
5. Remove the bracket holding the controller (1 screw). (Figure 76)
6. Disconnect wire harness at the fan assembly, the electrical connections to the 3 solenoid valves, and the ignition line.
7. Remove 3 screws and brackets securing the water line connections. (Figure 77)
8. Remove the 5 screws that attach the gas manifold to the combustion chamber (part of the heat exchanger assembly). (Figure 77)
9. Remove the 2 screws that attach the gas manifold to the gas valve. These screws are machine screws and must be used at these locations. (Figure 77)
10. Pull out the gas manifold and remove the connector at the ignitor at the left side of the gas manifold.
11. Remove the 9 screws attaching the burner cover plate to the combustion chamber. (Figure 78)
12. Remove the 2 screws attaching the burner to the heat exchanger. Pull out the burner. (Figure 78)
13. Remove the wire harness attachments - sensors, heating elements, fusible link brackets. Ensure that the small O-ring at the thermistor is removed.

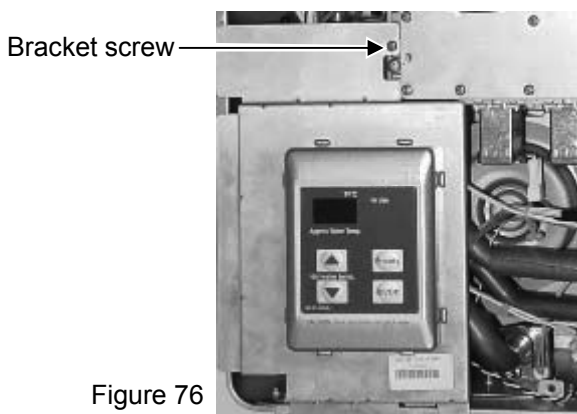

Figure 76

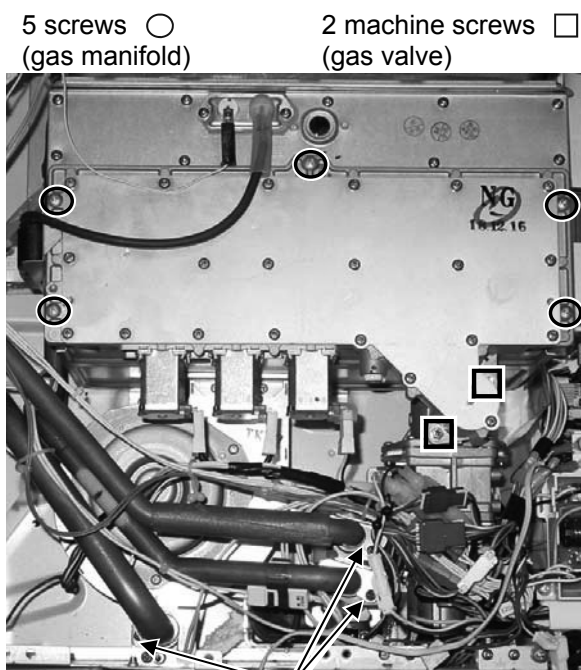

Figure 77

Water line connections

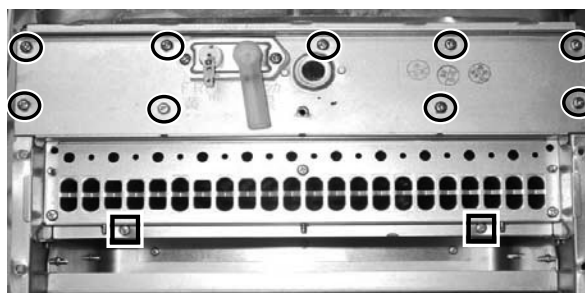

Figure 78

9 screws ○ (burner cover plate) 2 screws □ (burner)

Component Replacement Instructions

705i (ASME)

Heat Exchanger

14. Remove the 3 screws at the seal plate at the top of the water heater. Remove the seal plate and gasket. (Figure 79)
15. Remove flue outlet vent (4 screws). (Figure 80)
16. Remove the 4 screws connecting the heat exchanger to the back of the casing. (Figure 81)
17. Pull out the assembly. (It is hooked on brackets in the casing.) Remove the brackets on the side and back holding the fusible link. Slide off the fusible link.
18. Remove the fan assembly (4 screws) and install it on the new heat exchanger. (Figure 82)
19. Install the largest O-ring (included in kit) over the water outlet tube and the two smaller O-rings (included in kit) over the water inlet tubes. (Figure 82)
20. Slide the fusible link between the water outlet and inlet tubes and onto the new heat exchanger. (Figure 82)
21. Attach brackets at the back and side holding the fusible link. Install the heat exchanger hooking it on the brackets in the back.
22. Install the 4 screws at the top and bottom of the heat exchanger to the back of the casing. (Figure 81)
23. Install the flue outlet vent (4 screws) and seal plate (3 screws) and gasket at the top of the water heater. (Figures 79 and 80)



Figure 79



Figure 80

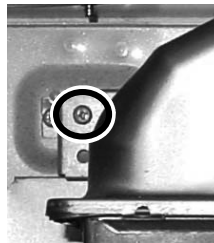

Top left screw

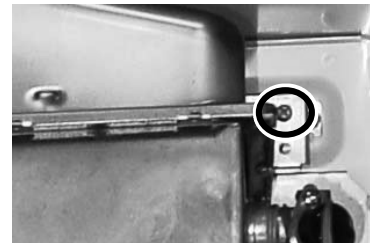

Top right screw

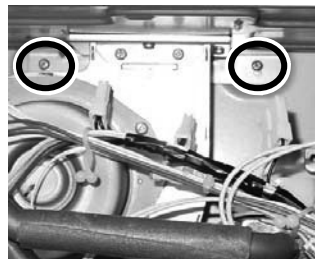

Figure 81 Bottom screws

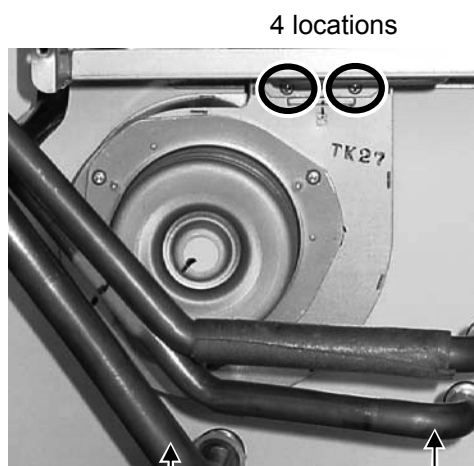

Figure 82

Water outlet tube

Water inlet tubes

Component Replacement Instructions

705i (ASME)

Heat Exchanger

24. Insert the burner and place the burner cover plate into position. Attach the burner cover plate first with 9 screws and then attach the burner with 2 screws. (Figure 78)
25. Replace the electrode gasket. (Figure 83)
26. Make sure that the black gasket (Figure 84) is intact on the gas control assembly. Replace the lower and upper gaskets (included in kit) for the manifold plate removing any residue. (Figure 85)
27. Attach the electrical connector to the ignitor on the manifold and attach the gas manifold with 2 machine screws at the gas control assembly. (Figure 77)
28. Attach the gas manifold with 5 screws at heat exchanger. (Figure 77)
29. Connect wire harness attachments.
30. Attach the ignition line at the burner cover plate.
31. Attach the 3 electrical connectors to the solenoid valves.
32. Attach the wire harness to the fan assembly (white, yellow, black, red wires).
33. Attach the brackets to the water line connections. (Figure 77)
34. Install the front panel using 4 screws.
35. Turn on the water supply, power supply, and gas supply.
36. Check for gas leaks.

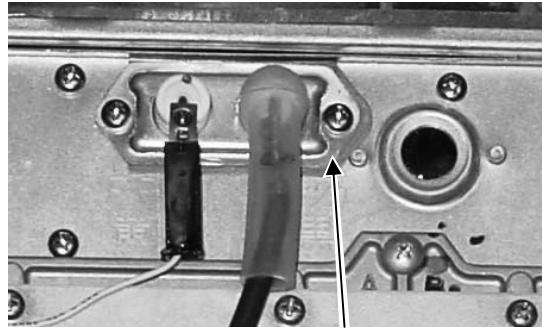

Figure 83 Electrode Gasket

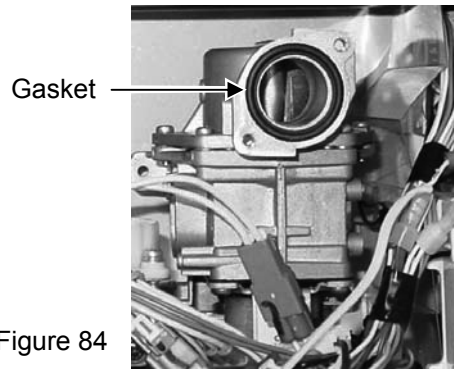

Figure 84

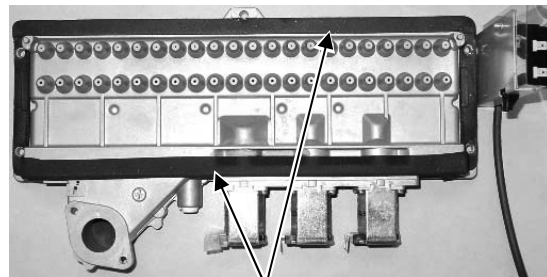

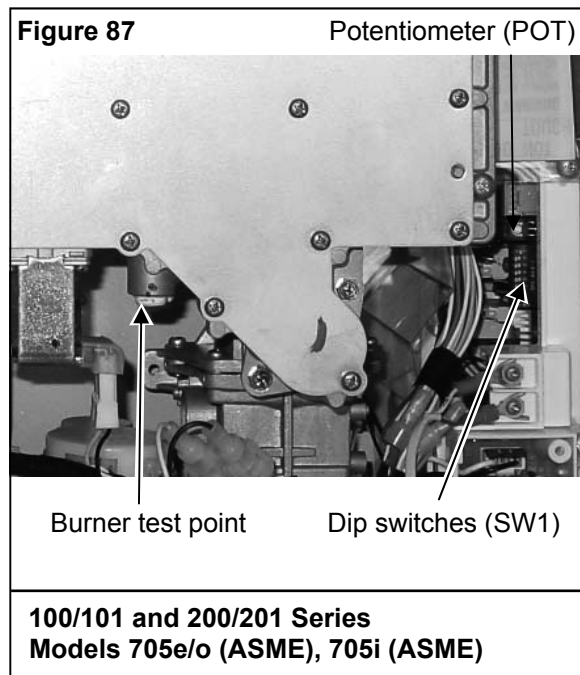
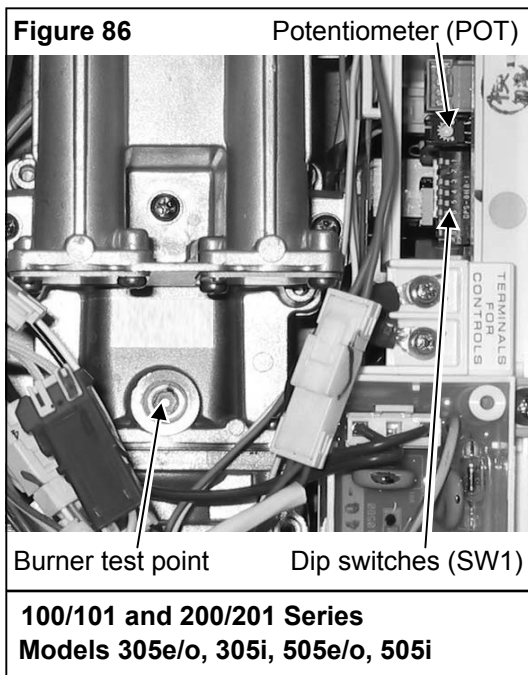

Figure 85 Gaskets

Gas Pressure Setting Procedure

 CAUTION 
Do not touch the areas at or near the heat exchanger or combustion chamber. These areas become very hot and could cause burns.

1. Remove the front panel (four screws).
2. Calibrate the low fire and high fire settings as follows:
 - A. Remove the allen head plug and attach the manometer to the burner test point located on the gas control (Figure 86 or 87).



Gas Pressure Setting Procedure

- B. Turn on the gas supply.
 - C. Turn on the power supply.
 - D. Flow water through the water heater at the maximum flow rate obtainable. (At least 3 gallons per minute is recommended.)
 - E. Move No. 7 dip switch of the SW1 bank to the ON position to calibrate “Forced Low” combustion. (Figure 89)
 - F. Check the burner test point pressure.
 - G. Remove the rubber access plug (Figure 88) and adjust the regulator screw on the modulating valve to obtain the correct low fire manifold pressure. Refer to the data plate on the unit. Install rubber access plug.
 - H. Move No. 7 and No. 8 dip switches of the SW1 bank to the ON position to calibrate “Forced High” combustion. (Figure 90)
 - I. Check the burner test point pressure.
 - J. Adjust the high pressure Potentiometer (POT) (Figure 86 or 87) on the PC Board to obtain the correct high fire manifold pressure. Refer to the data plate on the unit.
 - K. Move No. 7 and No. 8 back to the OFF position to return the appliance to “Normal” combustion. (Figure 91)
 - L. Close hot water taps.
 - M. Turn off gas supply and 120 V power supply.
 - N. Remove manometer and re-install allen head plug.
 - O. Turn on the gas supply and 120 V power supply.
 - P. Operate the unit and check for gas leaks.
3. Install the front panel using four screws.

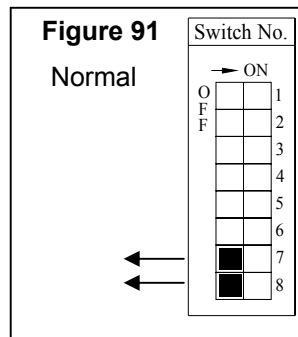
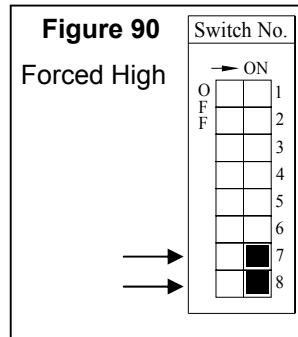
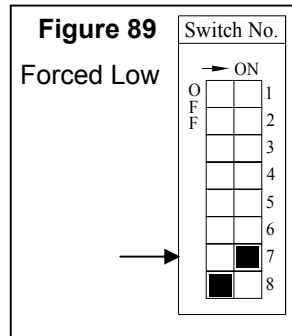
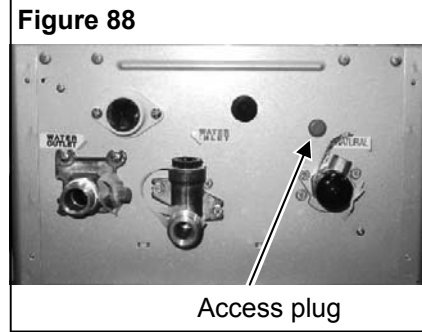

Manifold Gas Pressure Settings

100/101 and 200/201 Series

	Altitude	Natural Gas (Inch - W.C.)		Propane Gas (Inch - W.C.)	
		High Fire	Low Fire	High Fire	Low Fire
305e/o	less than 10200 ft (3109 m)	2.9	0.56	4.2	0.88
505e/o		3.3	0.56	5.1	0.88
705e/o (ASME)		2.8	0.65	3.8	0.80
305i		2.7	0.52	4.4	0.92
505i		3.3	0.52	5.0	0.92
705i (ASME)		3.0	0.67	3.7	0.83

Dip Switch Settings

100/101 and 200/201 Series

SW1 Bank

1	OFF - "Long Flue" ON - "Short Flue" and Outdoor Models "Long flue" is defined as: 0 elbows and length is greater than 21 ft 1 elbow and length is greater than 15 ft 2 elbows and length is greater than 9 ft			
2	Settings dependent on altitude			
3				
	0-2000 ft (0-610 m)	2001-5200 ft (610-1585 m)	5201-7700 ft (1585-2347 m)	7701-10200 ft (2347-3109 m)
	#2: OFF	#2: OFF	#2: ON	#2: ON
	#3: OFF	#3: ON	#3: OFF	#3: ON
4	OFF - if using standard controller			
5	OFF - 120°F default temperature without a controller ON - 140°F default temperature without a controller			
6	OFF position			
7	OFF position - Used for low fire and high fire settings. Refer to the gas pressure setting procedure.			
8				

SW2 Bank (present on replacement PC boards only)

1	OFF - Propane Gas ON - Natural Gas
2	OFF - Outdoor model ON - Indoor model
3	OFF - 305e, 305i, 505e, 505i, 705e/o (ASME), 705i (ASME)
4	OFF - 505e/o, 505i, 705e/o (ASME), 705i (ASME) ON - 305e/o, 305i
5	OFF - 305e, 305i, 505e, 505i, 705e/o (ASME), 705i (ASME)
6	OFF position

Notes

• 500 Tennessee Waltz Parkway • Ashland, TN 37015 •