

## COMMERCIAL GAS WATER HEATERS



500 Tennessee Waltz Parkway  
Ashland City, TN 37015



**MODELS SUF-130- 300/400/500  
SERIES 100 & 101**

**INSTALLATION - OPERATION - SERVICE  
- MAINTENANCE - LIMITED WARRANTY**



**WARNING:** If the information in these instructions is not followed exactly, a fire or explosion may result causing property damage, personal injury or death.

- Do not store or use gasoline or other flammable vapors and liquids in the vicinity of this or any other appliance.
- **WHAT TO DO IF YOU SMELL GAS:**
  - Do not try to light any appliance.
  - Do not touch any electrical switch; do not use any phone in your building.
  - Immediately call your gas supplier from a neighbor's phone. Follow the gas supplier's instructions.
  - If you cannot reach your gas supplier, call the fire department.
- Installation and service must be performed by a qualified installer, service agency or the gas supplier.

Thank you for buying this energy efficient water heater.  
We appreciate your confidence in our products.



### **WARNING**

Read and understand this instruction manual and the safety messages herein before installing, operating or servicing this water heater.

Failure to follow these instructions and safety messages could result in death or serious injury.

This manual must remain with the water heater.

**PLACE THESE INSTRUCTIONS ADJACENT TO HEATER AND NOTIFY OWNER TO KEEP FOR FUTURE REFERENCE.**





# TABLE OF CONTENTS

SAFE INSTALLATION, USE AND SERVICE.....	3	Supply Gas Line Installation.....	37
GENERAL SAFETY INFORMATION.....	4	Supply Gas Regulator Installation.....	38
Precautions.....	4	Electrical Wiring.....	39
INTRODUCTION.....	6	Power Supply Connections.....	39
Qualifications.....	6	Enable/Disable Circuit.....	39
iCOMM™ & BACnet Compatible.....	6	Water Line Connections.....	40
Preparing For The Installation.....	6	T&P Valve Discharge Pipe.....	40
FEATURES AND COMPONENTS.....	7	TEMPERATURE REGULATION.....	41
Basic Operation.....	7	High Temperature Limit Control (ECO).....	41
Top View.....	8	Thermostat Control.....	41
Side Views.....	9	CONTROL SYSTEM OPERATION.....	42
INSTALLATION CONSIDERATIONS.....	10	Control System Navigation.....	42
Rough In Dimensions.....	10	The Desktop Screen.....	42
Recovery Capacities.....	10	Status Icons.....	43
Locating The Water Heater.....	11	User Settings & Control System Menus.....	45
Clearance To Combustible Materials.....	11	Temperatures Menu.....	45
Service Clearance.....	11	Heater Status Menu.....	46
Insulation Blankets.....	12	Display Settings.....	47
INSTALLATION REQUIREMENTS.....	13	Heater Information.....	47
Gas Pressure Requirements.....	13	Current Fault.....	48
Supply Gas Line.....	13	Fault History.....	48
Supply Gas Regulator.....	13	Fault Occurrence.....	48
Power Supply.....	13	Restore Factory Defaults.....	48
Mixing Valves.....	14	Service Contact Information.....	49
Dishwashing Machines.....	14	START UP.....	50
Closed Water Systems.....	14	Initial Start Up.....	50
Thermal Expansion.....	14	Supply Gas Pressure Adjustment.....	51
Temperature-Pressure Relief Valve.....	15	Manifold Gas Pressure Adjustment.....	51
Condensate Drain.....	16	Checking The Firing Rate.....	52
Air Requirements.....	17	High Altitude Installations.....	52
Commonwealth of Massachusetts.....	20	LIGHTING THE WATER HEATER.....	53
VENTING INSTALLATION.....	21	Lighting & Operation Label.....	53
General Venting Information.....	21	TROUBLESHOOTING.....	54
Category IV Appliance.....	21	Installation Checklist.....	54
Power Vent Configuration.....	21	Sequence Of Operation.....	54
Direct Vent Configuration.....	21	Sequence Of Operation Flow Chart.....	55
General Venting Instructions.....	21	Operational Problems.....	56
Venting Requirements.....	22	Rough Starting, Rough Operation.....	56
Maximum Equivalent Lengths.....	22	Momentary Ignition.....	56
Minimum Equivalent Lengths.....	22	Not Enough Or No Hot Water.....	56
Maximum Number Of Elbows.....	22	Fault And Alert Conditions.....	57
Venting Installation Sequence.....	23	Fault Conditions.....	57
Power Vent Installation.....	23	Alert Conditions.....	57
Direct Vent Installation.....	23	Resetting Control System Lock Outs.....	57
Vertical Termination Installation.....	24	Diagnostic Checks.....	57
Sidewall Termination Installation.....	26	Fault And Alert Messages.....	58
Concentric Termination Installation.....	27	MAINTENANCE.....	60
Multiple Concentric Termination Clearances.....	30	Maintenance Schedule.....	60
Multiple Concentric Termination Arrangements.....	31	DIAGRAMS.....	63
Venting Arrangements.....	32	CCB - Central Control Board Layout.....	63
Termination Clearances Sidewall Power Vent.....	34	SUF 130 300 Wiring Diagram.....	64
Termination Clearances Sidewall Direct Vent.....	35	SUF 130 400, 500 Wiring Diagram.....	65
WATER HEATER INSTALLATION.....	36	Circulation Pump Wiring Diagrams.....	66
Condensate Drain Installation.....	36	Water Piping Diagrams.....	67
		LIMITED WARRANTY.....	74

# SAFE INSTALLATION, USE AND SERVICE

The proper installation, use and servicing of this water heater is extremely important to your safety and the safety of others. Many safety-related messages and instructions have been provided in this manual and on your own water heater to warn you and others of a potential injury hazard. Read and obey all safety messages and instructions throughout this manual. It is very important that the meaning of each safety message is understood by you and others who install, use, or service this water heater.

	<p>This is the safety alert symbol. It is used to alert you to potential personal injury hazards. Obey all safety messages that follow this symbol to avoid possible injury or death.</p>
---	---

	<p>DANGER indicates an imminently hazardous situation which, if not avoided, will result in injury or death.</p>
	<p>WARNING indicates a potentially hazardous situation which, if not avoided, could result in injury or death.</p>
	<p>CAUTION indicates a potentially hazardous situation which, if not avoided, could result in minor or moderate injury.</p>
	<p>CAUTION used without the safety alert symbol indicates a potentially hazardous situation which, if not avoided, could result in property damage.</p>

All safety messages will generally tell you about the type of hazard, what can happen if you do not follow the safety message, and how to avoid the risk of injury.

The California Safe Drinking Water and Toxic Enforcement Act requires the Governor of California to publish a list of substances known to the State of California to cause cancer, birth defects, or other reproductive harm, and requires businesses to warn of potential exposure to such substances.

This product contains a chemical known to the State of California to cause cancer, birth defects, or other reproductive harm. This appliance can cause low level exposure to some of the substances listed in the Act.

## APPROVALS



# GENERAL SAFETY INFORMATION

## PRECAUTIONS

DO NOT USE THIS APPLIANCE IF ANY PART HAS BEEN UNDER WATER. Immediately call a qualified service agency to inspect the appliance and to make a determination on what steps should be taken next.

If the unit is exposed to the following, do not operate heater until all corrective steps have been made by a qualified service agency.

1. External fire.
2. Damage.
3. Firing without water.

## GROUNDING INSTRUCTIONS

This water heater must be grounded in accordance with the National Electrical Code and/or local codes. These must be followed in all cases. Failure to ground this water heater properly may also cause erratic control system operation.

This water heater must be connected to a grounded metal, permanent wiring system; or an equipment grounding conductor must be run with the circuit conductors and connected to the equipment grounding terminal or lead on the water heater.

## HYDROGEN GAS FLAMMABLE

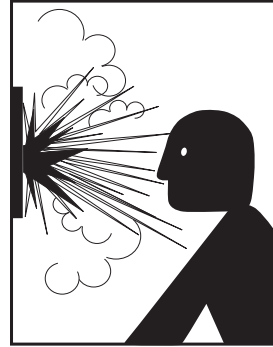

### **! WARNING**

#### **Explosion Hazard**

- Flammable hydrogen gases may be present.
- Keep all ignition sources away from faucet when turning on hot water.

Hydrogen gas can be produced in a hot water system served by this appliance that has not been used for a long period of time (generally two weeks or more). Hydrogen gas is extremely flammable. To reduce the risk of injury under these conditions, it is recommended that a hot water faucet served by this appliance be opened for several minutes before using any electrical appliance connected to the hot water system. If hydrogen is present there will probably be an unusual sound such as air escaping through the pipe as the water begins to flow. THERE SHOULD BE NO SMOKING OR OPEN FLAME NEAR THE FAUCET AT THE TIME IT IS OPEN.

**Verify the power to the water heater is turned off before performing any service procedures.**



### **! WARNING**

Read and understand this instruction manual and the safety messages herein before installing, operating or servicing this water heater.

Failure to follow these instructions and safety messages could result in death or serious injury.

This manual must remain with the water heater.

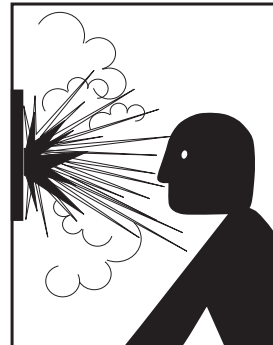

### **! WARNING**

#### **Explosion Hazard**

- Overheated water can cause water tank explosion.
- Properly sized temperature and pressure relief valve must be installed in the opening provided.

### **! DANGER**

Water temperature over 125°F (52°C) can cause severe burns instantly resulting in severe injury or death.

Children, the elderly and the physically or mentally disabled are at highest risk for scald injury.

Feel water before bathing or showering.

Temperature limiting devices such as mixing valves must be installed when required by codes and to ensure safe temperatures at fixtures.

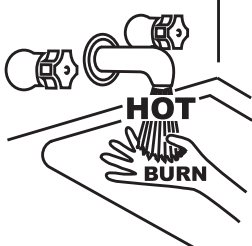

## CAUTION

**Improper installation, use and service may result in property damage.**

- Do not operate water heater if flood damaged.
- Inspect and anode rods regularly, replace if damaged.
- Install in location with drainage.
- Fill tank with water before operation.
- Properly sized thermal expansion tanks are required on all closed water systems.

Refer to this manual for installation and service.

# GENERAL SAFETY INFORMATION

## ⚠️ WARNING

### Fire or Explosion Hazard

- Do not store or use gasoline or other flammable vapors and liquids in the vicinity of this or any other appliance.
- Avoid all ignition sources if you smell gas.
- Do not expose water heater controls to excessive gas pressure.
- Use only the gas shown on the water heater rating label.
- Maintain required clearances to combustibles.
- Keep ignition sources away from faucets after extended periods of non-use.



Read instruction manual before installing, using or servicing water heater.



## ⚠️ WARNING

### Breathing Hazard - Carbon Monoxide Gas



- Do not obstruct water heater air intake with insulating blanket.
- Gas and carbon monoxide detectors are available.
- Install water heater in accordance with the instruction manual.

Breathing carbon monoxide can cause brain damage or death. Always read and understand instruction manual.

## CAUTION

### Property Damage Hazard

- All water heaters eventually leak.
- Do not install without adequate drainage.

## ⚠️ WARNING

### Electrical Shock Hazard



- Turn off power to the water heater before performing any service.
- Label all wires prior to disconnecting when performing service. Wiring errors can cause improper and dangerous operation.
- Verify proper operation after servicing.
- Failure to follow these instructions can result in personal injury or death.

## ⚠️ WARNING

### Fire Hazard



For continued protection against risk of fire:

- Do not install water heater on carpeted floor.
- Do not operate water heater if flood damaged.

## ⚠️ WARNING

### Fire and Explosion Hazard



- Use joint compound or Teflon tape compatible with propane gas.
- Leak test before placing the water heater in operation.
- Disconnect gas piping and main gas shutoff valve before leak testing.
- Install sediment trap in accordance with NFPA 54.

## ⚠️ WARNING

### Fire and Explosion Hazard



- Do not use water heater with any gas other than the gas shown on the rating label.
- Excessive gas pressure to gas valve can cause serious injury or death.
- Turn off gas lines during installation.
- Contact a qualified installer or service agency for installation and service.

## ⚠️ WARNING

### Jumping out control circuits or components can result in property damage, personal injury or death.

- Service should only be performed by a qualified service agent using proper test equipment.
- Altering the water heater controls and/or wiring in any way could result in permanent damage to the controls or water heater and is not covered under the limited warranty.
- Altering the water heater controls and/or wiring in any way could result in altering the ignition sequence allowing gas to flow to the main burner before the hot surface igniter is at ignition temperature causing delayed ignition which can cause a fire or explosion.



Any bypass or alteration of the water heater controls and/or wiring will result in voiding the appliance warranty.





# INTRODUCTION

Thank You for purchasing this water heater. Properly installed and maintained, it should give you years of trouble free service.

## ABBREVIATIONS USED

Abbreviations found in this Instruction Manual include :

- ANSI - American National Standards Institute
- ASME - American Society of Mechanical Engineers
- GAMA - Gas Appliance Manufacturer's Association
- NEC - National Electrical Code
- NFPA - National Fire Protection Association
- UL - Underwriters Laboratory
- CSA - Canadian Standards Association

## QUALIFICATIONS

### QUALIFIED INSTALLER OR SERVICE AGENCY

Installation and service of this water heater requires ability equivalent to that of a Qualified Agency (as defined by ANSI below) in the field involved. Installation skills such as plumbing, air supply, venting, gas supply and electrical supply are required in addition to electrical testing skills when performing service.

**ANSI Z223.1 2006 Sec. 3.3.83:** "Qualified Agency" - "Any individual, firm, corporation or company that either in person or through a representative is engaged in and is responsible for (a) the installation, testing or replacement of gas piping or (b) the connection, installation, testing, repair or servicing of appliances and equipment; that is experienced in such work; that is familiar with all precautions required; and that has complied with all the requirements of the authority having jurisdiction."

If you are not qualified (as defined by ANSI above) and licensed or certified as required by the authority having jurisdiction to perform a given task do not attempt to perform any of the procedures described in this manual. If you do not understand the instructions given in this manual do not attempt to perform any procedures outlined in this manual.

### ICOMM™ & BACNET COMPATIBLE

This water heater is compatible with the iCOMM™ remote monitoring system. The iCOMM™ system hardware and monitoring service is purchased separately. It allows users to monitor critical operational, diagnostic and energy usage data from a secure web site.

The iCOMM™ system can automatically notify selected personnel via email and/or cellular phone text messages if operational problems or user defined Alert Conditions occur.

iCOMM™ system hardware is compatible with BACnet compliant supervisory controls and building management systems. For more information call 888 928-3702.

## PREPARING FOR THE INSTALLATION

1. Read the entire manual before attempting to install or operate the water heater. Pay close attention to the General Safety Information on page 4 and 5. If you don't follow the safety rules, the water heater may not operate safely. It could cause property damage, injury and/or death.

This manual contains instructions for the installation, operation, and maintenance of the water heater. It also contains warnings throughout the manual that you must read and be aware of. All warnings and all instructions are essential to the proper operation of the water heater and your safety.

Detailed installation diagrams are also found in this manual. These diagrams will serve to provide the installer with a reference. It is essential that all venting, water piping, gas piping and wiring be installed as shown.

Particular attention should be given to the installation of thermometers at the locations indicated in the piping diagrams as these are necessary for checking the operation of the water heater.

The principal components of the water heater are identified in Features And Components on page 7 in this manual. Use this reference to locate and identify various components on the water heater.

See the Installation Checklist and Troubleshooting on page 54. By using this checklist the user may be able to make minor operational adjustments and avoid unnecessary service calls. However, service and diagnostic procedures should only be performed by a Qualified Service Agency.

**NOTE:** Costs to correct installation errors are not covered under the limited warranty.

2. Be sure to turn off power when working on or near the electrical system of the water heater. Never touch electrical components with wet hands or when standing in water.
3. The installation must conform to all instructions contained in this manual and the local code authority having jurisdiction. These shall be carefully followed in all cases. Authorities having jurisdiction should be consulted before installation begins if there are any questions regarding compliance with local, state or national codes.

In the absence of local codes, the installation must comply with the current editions of the National Fuel Gas Code, ANSI Z223.1/NFPA 54 and the National Electrical Code, NFPA 70 or CAN/CSA-B149.1, the Natural Gas and Propane Installation Code and CSA C22.1, the Canadian Electrical Code. All documents are available from the Canadian Standards Association, 8501 East Pleasant Valley Road, Cleveland, OH 44131. NFPA documents are also available from the National Fire Protection Association, 1 Batterymarch Park, Quincy, MA 02269.

4. If after reading this manual you have any questions or do not understand any portion of the instructions, call the toll free number on the back cover of this manual for technical assistance. In order to expedite your request, please have the full Model, Serial and Series number of the water heater you are working with available for the technician. This information is located on the water heater's rating label.
5. Carefully plan the placement of the water heater. Examine the location to ensure that it complies with the requirements in Locating The Water Heater on page 11 and the Rough In Dimensions on page 10.
6. For installation in California this water heater must be braced or anchored to avoid falling or moving during an earthquake. See instructions for correct installation procedures. Instructions may be obtained from California Office of the State Architect, 1102 Q Street, Suite 5100, Sacramento, CA 95811.
7. Massachusetts Code requires this water heater to be installed in accordance with Massachusetts 248-CMR 2.00: State Plumbing Code and 248-CMR 5. See Commonwealth of Massachusetts on page 20.

# FEATURES AND COMPONENTS

## BASIC OPERATION

The water heaters covered in this manual have a helical coil shaped heat exchanger that is submerged in the storage tank. The water heater's Main Burner is a radial design burner, it is mounted on the top and fires downward through the heat exchanger. This is a forced draft burner; hot burning gases are forced through the heat exchanger under pressure and exit through the exhaust/vent connection located at the bottom of the water heater. See Figure 1 and Figure 2.

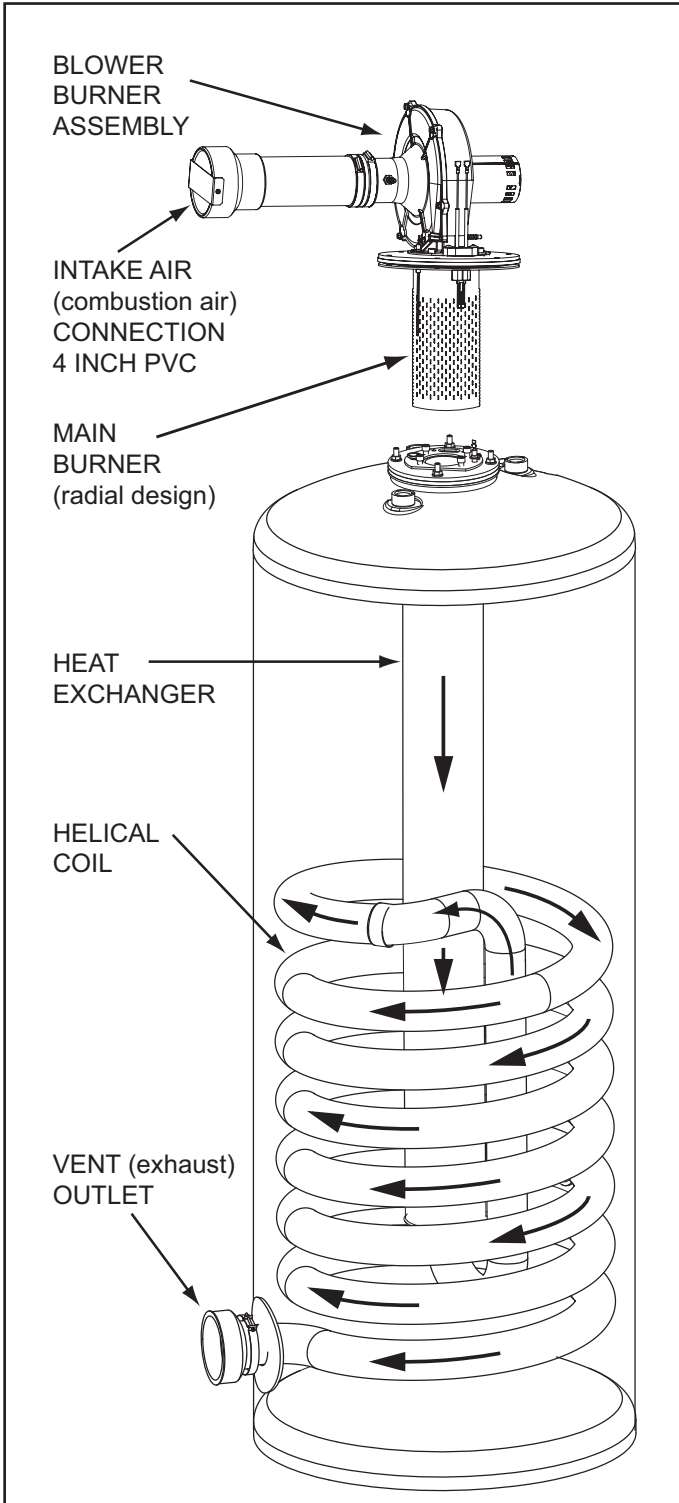

Figure 1

## BLOWER/BURNER ASSEMBLY DETAIL

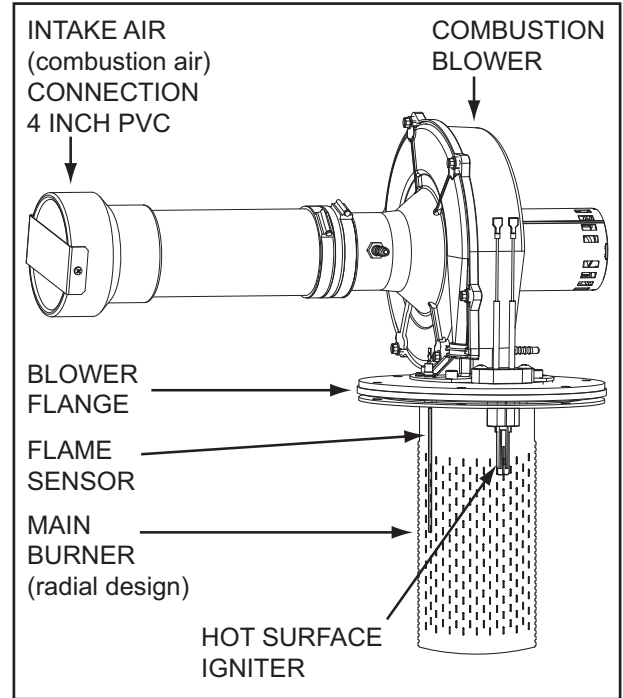

Figure 2

### Hot Surface Igniter

The control system energizes the Hot Surface Igniter with 120 VAC during the igniter warm up period. When the igniter is energized it produces sufficient heat,  $>1800^{\circ}\text{F}$  ( $>982^{\circ}\text{C}$ ), to ignite the Main Burner.

**NOTE:** Care must be taken when handling the igniter to prevent breakage.

During the igniter warm up period prior to ignition the control system monitors the igniter current and must sense a minimum of 2.0 AC amps for SUF 130 300 & 400 models and 2.7 AC amps for SUF 130 500 models. See the Sequence Of Operation on page 54.

### Flame Sensor

The control system also monitors the flame sensor to confirm a flame is present at the Main Burner. If a flame is not verified during the ignition trial period (3-5 seconds) the control system will immediately de-energize the 24 VAC Gas Valve. See the Sequence Of Operation Flow Chart on page 55.

## TOP VIEW

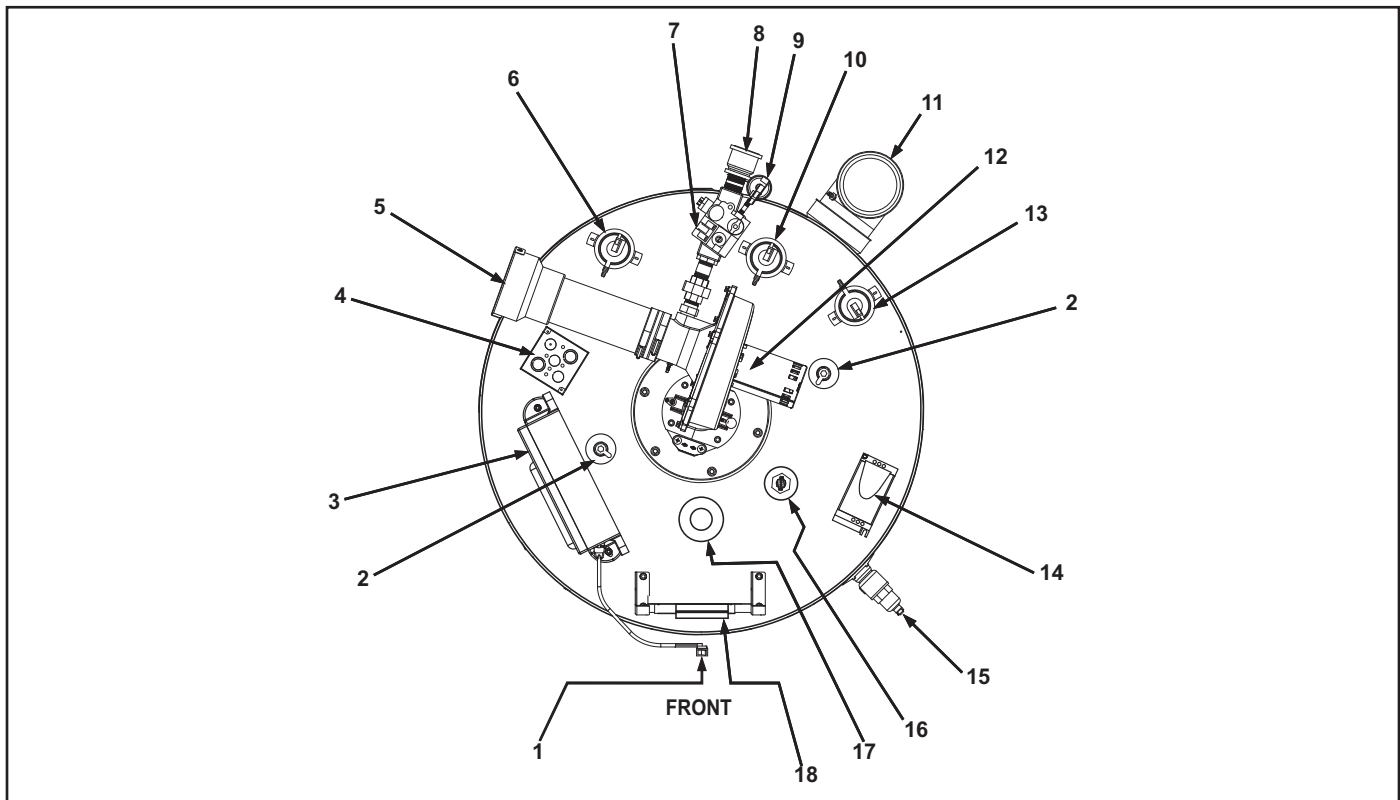

Figure 3

### TOP VIEW COMPONENTS

1. Water Heater's 120 VAC on/off switch.
2. Powered anode rods. The water heater's covered in this manual are equipped with two powered (non sacrificial) anode rods. Protective current is fed by the control system to the titanium electrodes at the end of each anode rod. This current flows through the water to the conductive surfaces inside the storage tank which diminishes the corrosive effect (rusting) of water when it comes in contact with steel.
3. Central Control Board (CCB) enclosure. This enclosure houses the control system's main circuit board. The CCB regulates water temperature and controls all water heater functions, see Control System Operation on page 42.
4. 120 VAC junction box. Incoming power supply and ground connections are made here. See Power Supply on page 13.
5. Intake air connection - 4 inch PVC.
6. Blocked Intake Air switch. Normally closed contacts that open on fall in pressure. This switch is used to insure intake (combustion) air to the water heater is not restricted. The control system monitors this switch and will disable heating operation if its contacts are open during a heating cycle.
7. Water heater's 24 VAC Gas Valve.
8. Supply gas line connection. See the requirements for the Supply Gas Line on page 13.
9. Low Gas Pressure switch. Normally open contacts that close on a rise in pressure. This switch is used to insure supply gas pressure is above minimum requirements. The control system monitors this switch and will disable heating operation if its contacts are open during a heating cycle. See Table 4 and the Gas Pressure Requirements on page 13.
10. Blower Prover switch. Normally open contacts that close on a rise in pressure. This switch is used to insure the Combustion Blower is operating properly. The control system monitors this switch and will disable heating operation if its contacts are closed before the Combustion Blower is energized or open any time during a heating cycle. See Sequence Of Operation on page 54.
11. Vent connection (exhaust elbow) - 4 inch PVC.
12. Combustion Blower.
13. Blocked Exhaust (vent) switch. Normally closed contacts that open on a rise in pressure. This switch is used to insure the Exhaust (vent) piping connected to the water heater is not restricted. The control system monitors this switch and will disable heating operation if its contacts are open during a heating cycle.
14. VFD (variable frequency drive) blower motor drive. Used on SUF 130 400 and SUF 130 500 models only.
15. Temperature-Pressure Relief Valve. See Temperature-Pressure Relief Valve on page 15.
16. Upper Temperature Probe, 1 of 2 temperature probes. The water heater's control system monitors this probe to detect water temperature in the upper portion of the storage tank.  
The Upper Temperature Probe also houses the ECO (energy cut out) switch. This is a non adjustable high temperature limit switch. The ECO switch contacts are normally closed and will open on a temperature rise. See High Temperature Limit Control (ECO) on page 41.
17. Water outlet connection 1 1/2" NPT.
18. UIM (user interface module). The UIM includes the display circuit board, the control system's LCD display and operational buttons. Used to adjust various user settings and view operational information. See Control System Operation on page 42.



## SIDE VIEWS

1. Cleanout access panel, covers water heater cleanout opening.
2. CCB enclosure - see Figure 3 on page 8 for description.
3. 120 VAC junction box. Incoming power supply and ground connections are made here - see requirements for Power Supply on page 13.
4. Intake air connection - 4 inch PVC.
5. Supply gas line connection. See Supply Gas Line on page 13.
6. Low Gas Pressure switch, see description under Figure 3 on page 8. See Table 4 and the Gas Pressure Requirements on page 13.
7. Water heater 24 VAC Gas Valve.
8. Water outlet pipe - 1 1/2" NPT connection.
9. VFD (variable frequency drive) blower motor drive - - see Figure 3 on page 8 for description.
10. UIM (user interface module). The UIM includes the display circuit board, the control system's LCD display and

operational buttons. Used to adjust various user settings and view operational information. See Control System Operation on page 42.

11. Temperature-Pressure Relief Valve. See Temperature-Pressure Relief Valve on page 15.
12. Temperature-Pressure Relief Valve discharge pipe - see T&P Valve Discharge Pipe Requirements: on page 15.
13. Lower Temperature Probe, 1 of 2 temperature probes. The water heater's control system monitors this probe to detect water temperature in the lower portion of the storage tank.
14. Water inlet pipe - 1 1/2" NPT connection.
15. Water heater drain valve.
16. Combustion Blower.
17. Vent connection (exhaust elbow) - 4 inch PVC.
18. Condensate trap with 1/2 inch PVC drain connection. See Figure 9 on page 16 and Condensate Drain Installation on page 36.

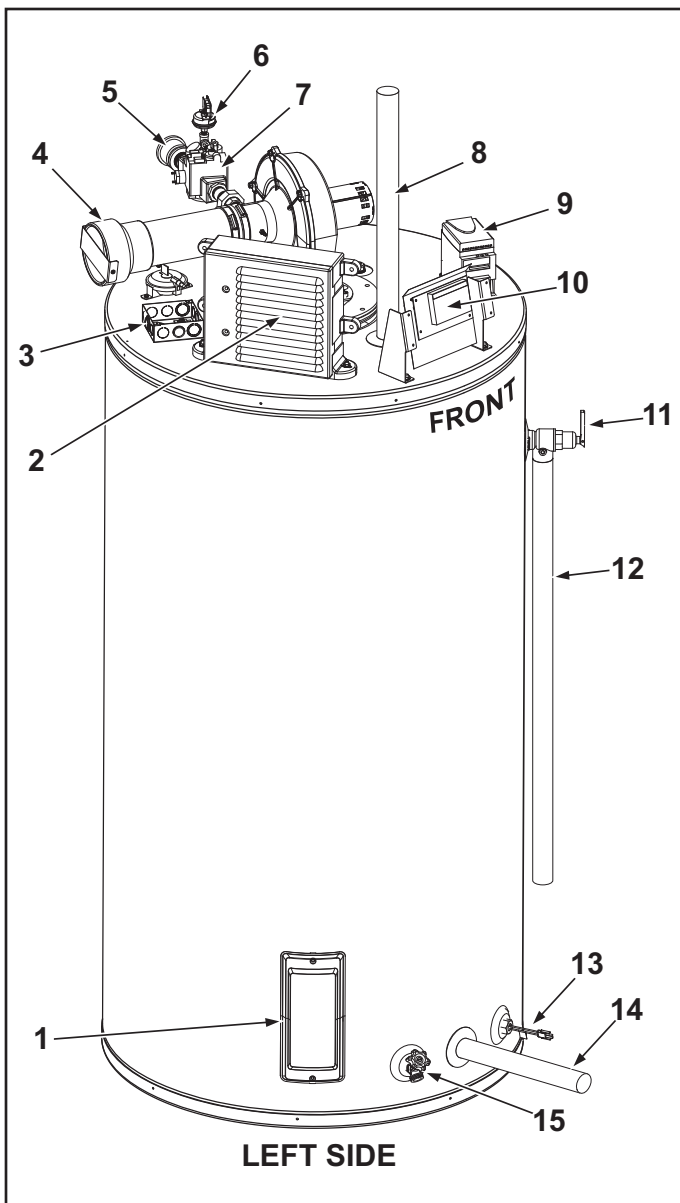

Figure 4

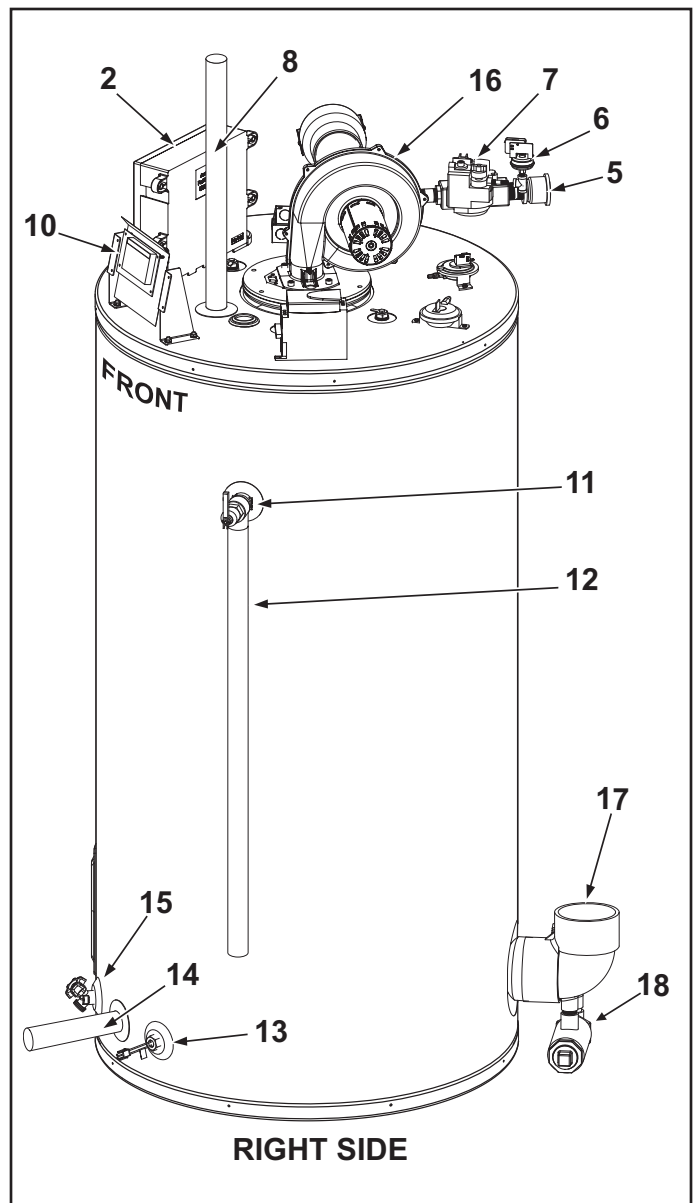

Figure 5

# INSTALLATION CONSIDERATIONS

## ROUGH IN DIMENSIONS

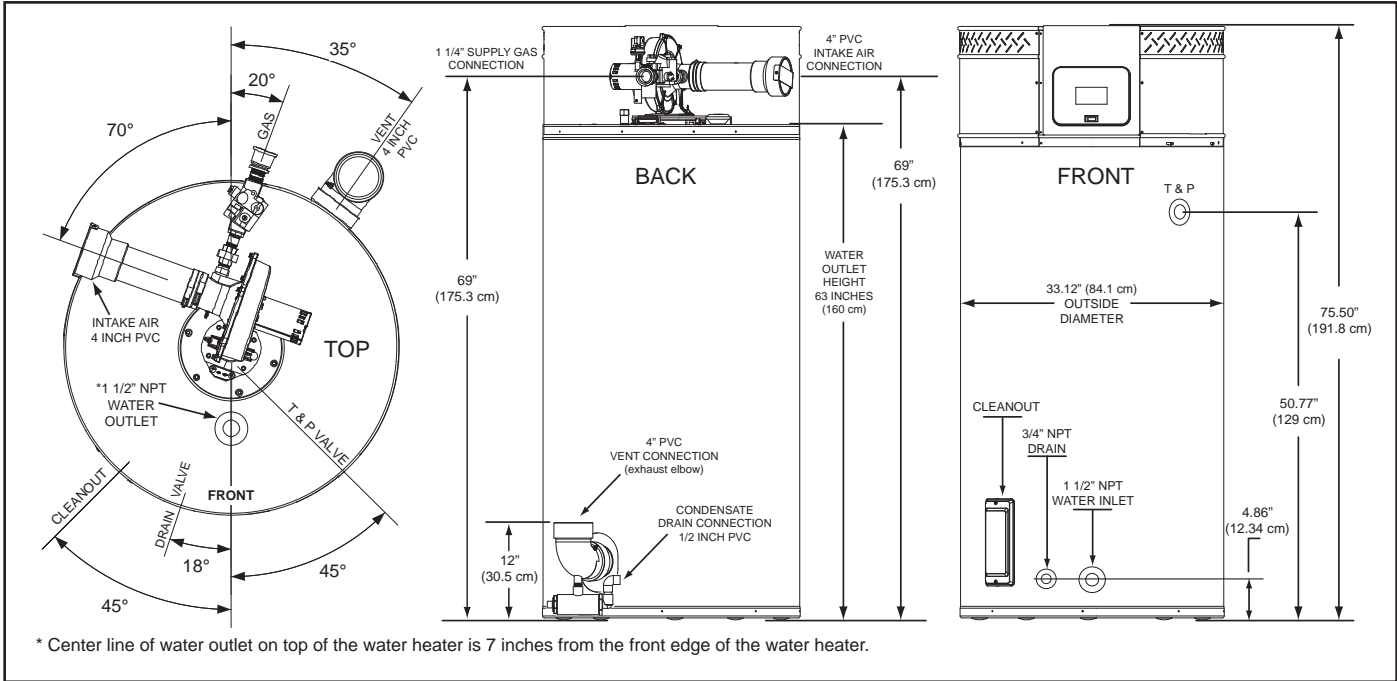

Figure 6

These designs comply with the current edition of the American National Standard for Gas Water Heaters, Volume III, ANSI Z21.10.3 / CSA 4.3 as an automatic circulating tank water heater, and automatic storage water heaters.

## GAS LINE CONNECTION SIZE

TABLE 1

MODEL	SERIES	NATURAL GAS	PROPANE GAS
SUF 130 300	100/101	1 1/4" NPT	1 1/4" NPT
SUF 130 400	100/101	1 1/4" NPT	1 1/4" NPT
† SUF 130 500	100/101	1 1/4" NPT	1 1/4" NPT

† This table shows connections sizes only. SUF 130 500 natural gas models require a 1 1/2" minimum supply gas line - see Table 5 on page 13 for minimum required supply gas line sizes. Depending on the installed equivalent length, and/or the number of appliances connected, the supply gas line size may have to be increased beyond the minimum required sizes - see Gas Line Sizing on

page 37.

## STORAGE CAPACITIES

TABLE 2

MODEL	U. S. GALLONS	LITERS
SUF 130 300	130	492
SUF 130 400	130	492
SUF 130 500	130	492

## RECOVERY CAPACITIES

TABLE 3

Model	Type of Gas	U. S. GALLONS/HR & LITERS/HR AT TEMPERATURE RISE INDICATED															
		Input		°F	20°F	30°F	40°F	50°F	60°F	70°F	80°F	90°F	100°F	110°F	120°F	130°F	140°F
		Btu/hr	kW	°C	11°C	17°C	22°C	28°C	33°C	39°C	44°C	50°C	56°C	61°C	67°C	72°C	78°C
SUF 130 300	Natural	300,000	88	GPH	1746	1164	873	699	582	499	436	388	349	318	291	269	250
	LPH			6610	4406	3304	2644	2203	1888	1652	1469	1322	1201	1102	1017	945	
SUF 130 400	Natural	399,900	117	GPH	2328	1552	1164	931	776	665	582	517	466	423	388	359	332
	LPH			8813	5875	4406	3525	2938	2518	2203	1958	1763	1602	1469	1356	1259	
SUF 130 500	Natural	499,900	146	GPH	2878	1919	1439	1151	959	822	720	640	576	523	480	443	411
	LPH			10894	7263	5447	4358	3631	3113	2724	2421	2179	1981	1816	1676	1556	

Recovery capacities are based on 96% thermal efficiency for SUF 130 300, SUF 130 400 and 95% thermal efficiency for SUF 130 500.



## LOCATING THE WATER HEATER

Carefully choose a location for the new water heater. The placement is a very important consideration for the safety of the occupants in the building and for the most economical use of the appliance.

<b>CAUTION</b>	
<b>Property Damage Hazard</b>	
<ul style="list-style-type: none"><li>• All water heaters eventually leak.</li><li>• Do not install without adequate drainage.</li></ul>	

Whether replacing an existing water heater or installing the water heater in a new location observe the following critical points:

1. The water heater must be located indoors.
2. The water heater must not be located in an area where it will be subject to freezing temperatures.
3. Locate the water heater so it is protected and not subject to physical damage by a moving vehicle.
4. Locate the water heater on a level surface.
5. Locate the water heater near a floor drain. The water heater should be located in an area where leakage of the tank or connections will not result in damage to the area adjacent to the water heater or to lower floors of the structure. When such locations cannot be avoided, it is recommended that a metal drain pan, adequately drained, be installed under the appliance.
6. Locate the water heater close to the point of major hot water usage.
7. Locate the water heater close to a 120 VAC power supply. See Power Supply on page 13 for requirements.
8. Locate the water heater where an adequate supply of fresh air for combustion and ventilation can be obtained. See Air Requirements on page 17.
9. Locate the water heater where the vent and intake air piping, when installed, will remain within the maximum equivalent lengths allowed. See Venting Requirements on page 22.
10. Do not locate the water heater where noise (such as the Combustion Blower) during normal operation will be objectionable in adjacent areas.
11. Do not locate the water heater where the subsequent installation of the vent (exhaust) or intake air terminations would be objectionable due to noise at the termination(s). This includes locations close to or across from windows and doors. See Venting Installation on page 21.

<b>WARNING</b>		
<b>Fire or Explosion Hazard</b>		
<ul style="list-style-type: none"><li>• Do not store or use gasoline or other flammable vapors and liquids in the vicinity of this or any other appliance.</li><li>• Avoid all ignition sources if you smell gas.</li><li>• Do not expose water heater controls to excessive gas pressure.</li><li>• Use only the gas shown on the water heater rating label.</li><li>• Maintain required clearances to combustibles.</li><li>• Keep ignition sources away from faucets after extended periods of non-use.</li></ul>		
	<p>Read instruction manual before installing, using or servicing water heater.</p>	

There is a risk in using fuel burning appliances such as gas water heaters in rooms, garages or other areas where gasoline, other flammable liquids or engine driven equipment or vehicles are stored, operated or repaired. Flammable vapors are heavy and travel along the floor and may be ignited by the water heater's igniter or Main Burner flames causing fire or explosion.

Flammable items, pressurized containers or any other potential fire hazardous articles must never be placed on or adjacent to the water heater.

### CLEARANCE TO COMBUSTIBLE MATERIALS

The water heaters covered in this manual are approved for installation on combustible flooring. The clearance to combustible and non combustible construction materials is 0 inches on the back and sides of the water heater. These water heaters are also approved for installation in an alcove.

**NOTE:** Adequate clearance for servicing should be maintained on all installations. See Service Clearance below.

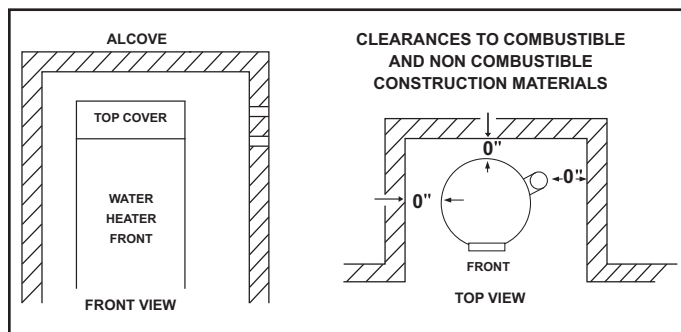

Figure 7

### SERVICE CLEARANCE

A service clearance of 24 inches (61 cm) should be maintained from serviceable parts such as the T&P valve, control system components, gas valve, clean out opening, drain valve, the vent connection (exhaust elbow) and the condensate drain. Leave as much room as possible above the water heater and near the exhaust elbow for this reason. See Figure 9 on page 16.

### INTAKE AIR AND VENT PIPE CLEARANCES

The minimum clearance from combustible materials for the vent (exhaust) and intake air piping shall be 0 inches. Vent or intake air piping passing through a combustible wall or ceiling must be a continuous run (no joints).

## EXTENDED VENT TERMINATIONS

The water heaters covered by this manual can be installed using 4 inch pipe for the intake air and/or vent piping up to a maximum of 70 equivalent feet (21.3 m). The intake air and/or vent piping can be extended up to 120 equivalent feet (36.5 m) by installing 6 inch pipe. See the Venting Requirements on page 22.

The water heater ships from the factory with two (2) 4 inch terminations that are 45° PVC elbows with a debris screen installed. When 6 inch intake air or vent pipe is installed, factory supplied 6 inch terminations must be used.

Contact your local distributor or call the parts department phone number listed on the back cover of this manual to order 6 inch termination(s).

## OPTIONAL CONCENTRIC TERMINATIONS

The water heaters covered by this manual can be installed in a Direct Vent configuration using optional concentric terminations.

SUF 130 300 models installed using 4 inch vent/intake air piping use the 4 inch concentric termination. SUF 130 300 models installed using 6 inch vent/intake air piping use the 6 inch concentric termination. SUF 130 400 and 500 models must use the 6 inch concentric termination on all installations. See the Venting Requirements on page 22 and Concentric Termination Installation on page 27.

Concentric terminations must be ordered separately. Contact your local distributor or call the parts department phone number listed on the back cover of this manual to order.

- 4" Concentric Termination Part # 9006328005
- 6" Concentric Termination Part # 9006144005

## HARD WATER

Where hard water conditions exist, water softening or the threshold type of water treatment is recommended. This will protect the dishwashers, coffee urns, water heaters, water piping and other equipment.

See Maintenance on page 60 for sediment and lime scale removal procedures.

## CIRCULATION PUMPS

A circulating pump is used when a system requires a circulating loop or there is a storage tank used in conjunction with the water heater. See the Water Piping Diagrams beginning on page 67 for installation location of circulating pumps.

See Circulation Pump Wiring Diagrams on page 66 for electrical hookup information. Install in accordance with the current edition of the National Electrical Code, NFPA 70 or the Canadian Electrical Code, CSA C22.1.

All-bronze circulators are recommended for used with commercial water heaters.

Some circulating pumps are manufactured with sealed bearings and do not require further lubrication. Some circulating pumps must be periodically oiled. Refer to the pump manufacturer's instructions for lubrication requirements.

## INSULATION BLANKETS

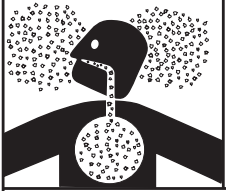
<b>! WARNING</b>	
<b>Breathing Hazard - Carbon Monoxide Gas</b>	
	<ul style="list-style-type: none"><li>• Do not obstruct water heater air intake with insulating blanket.</li><li>• Gas and carbon monoxide detectors are available.</li><li>• Install water heater in accordance with the instruction manual.</li></ul>
Breathing carbon monoxide can cause brain damage or death. Always read and understand instruction manual.	

Insulation blankets are available to the general public for external use on gas water heaters but are not necessary with these products. The purpose of an insulation blanket is to reduce the standby heat loss encountered with storage tank heaters. The water heaters covered by this manual meet or exceed the Energy Policy Act standards with respect to insulation and standby heat loss requirements, making an insulation blanket unnecessary.

Should you choose to apply an insulation blanket to this heater, you should follow these instructions. See the Features and Components section of this manual for identification of components mentioned below. Failure to follow these instructions can restrict the air flow required for proper combustion, potentially resulting in fire, asphyxiation, serious personal injury or death.

- **DO NOT** apply insulation to the top of the water heater, as this will interfere with safe operation of the blower assembly.
- **DO NOT** cover the control system LCD on top of the water heater.
- **DO NOT** cover the Temperature-Pressure Relief Valve.
- **DO NOT** cover the instruction manual. Keep it on the side of the water heater or nearby for future reference.
- **DO** obtain new warning and instruction labels from the manufacturer for placement on the blanket directly over the existing labels.
- **DO** inspect the insulation blanket frequently to make certain it does not sag, thereby obstructing combustion air flow.

# INSTALLATION REQUIREMENTS

## GAS PRESSURE REQUIREMENTS

**TABLE 4**

MODEL	*MANIFOLD PRESSURE		†MINIMUM SUPPLY PRESSURE		‡MAXIMUM SUPPLY PRESSURE	
	NATURAL GAS	PROPANE GAS	NATURAL GAS	PROPANE GAS	NATURAL GAS	PROPANE GAS
SUF 130 300	4" W. C. (1.0 kPa)	10" W. C. (2.49 kPa)	5.2" W. C. (1.29 kPa)	11" W. C. (2.74 kPa)	10" W. C. (2.49 kPa)	12" W. C. (2.99 kPa)
SUF 130 400	4" W. C. (1.0 kPa)	10" W. C. (2.49 kPa)	5.2" W. C. (1.29 kPa)	11" W. C. (2.74 kPa)	10" W. C. (2.49 kPa)	12" W. C. (2.99 kPa)
SUF 130 500	4" W. C. (1.0 kPa)	10" W. C. (2.49 kPa)	5.2" W. C. (1.29 kPa)	11" W. C. (2.74 kPa)	10" W. C. (2.49 kPa)	12" W. C. (2.99 kPa)

\* Manifold gas pressure; reading can only be taken while gas is flowing. Reading taken should be  $\pm 0.3$ " W. C. of the listed value. These water heaters are certified for use without modification for altitudes up to 10,000 feet. For elevations above 10,000 feet (3,048 meters) see High Altitude Installations on page 52.

† Minimum supply gas pressure; readings are taken while gas is not flowing (static pressure) AND while gas is flowing (dynamic pressure). Supply pressure must never fall below the minimum values. Supply gas pressures should be measured with all gas fired appliances connected to a common main firing at full capacity. If supply pressure drops more than 1.5" W. C. as gas begins to flow the supply gas system (gas line/regulator) may be restricted or undersized. See Table 5 and the Supply Gas Regulator requirements below. See Supply Gas Line Installation on page 37 and Supply Gas Regulator Installation on page 38 for sizing and installation instructions also.

‡ Maximum supply gas pressure; reading are taken while gas is not flowing (static pressure) AND while gas is flowing (dynamic pressure). Supply pressure must never exceed this maximum value.

## SUPPLY GAS LINE

The high efficiency water heaters covered in this manual require an adequate volume of fuel gas for proper operation. A lack of fuel gas volume can lead to ignition failure, rough starting and rough operation. Increasing the supply gas pressure DOES NOT necessarily increase the volume of gas supplied to the water heater and must remain below the maximum supply gas pressures shown in Table 4.

The minimum supply gas line sizes shown in Table 5 must be observed on all installations to help insure an adequate volume of fuel gas is provided. DO NOT use flexible gas piping.

Supply gas lines serving more than one appliance may require larger sizes than what is shown in Table 5. See Gas Line Sizing on page 37.

### MINIMUM SUPPLY GAS LINE SIZE

**TABLE 5**

MODEL	*NATURAL GAS	PROPANE GAS
SUF 130 300	1 1/4" NPT	1 1/4" NPT
SUF 130 400	1 1/4" NPT	1 1/4" NPT
† SUF 130 500	1 1/2" NPT	1 1/4" NPT

† Note that SUF 130 500 natural gas models require a 1 1/2" minimum supply gas line size. Depending on the installed equivalent length, and/or the number of appliances connected, the supply gas line size may have to be increased beyond the minimum required sizes shown in this table - see Gas Line Sizing on page 37.

## SUPPLY GAS REGULATOR

The high efficiency water heaters covered by this manual require a supply gas regulator to be installed in the supply gas line serving the water heater for proper operation. Supply gas regulators are required on high and low pressure gas supply systems.

**NOTE:** On multiple water heater installations each water heater shall have its own dedicated supply gas regulator installed in the supply gas line serving the water heater.

Supply gas regulators must be rated at or above the input Btu/hr rating of the water heater they supply. Supply gas regulators shall have inlet and outlet connections not less than the minimum supply gas line size for the water heater they serve as shown in Table 5. The Maxitrol 325-7L or equivalent is recommended.

See Supply Gas Regulator Installation on page 38.

## POWER SUPPLY

The water heaters covered in this manual require a 120 VAC, 1Ø (single phase), 60Hz, 15 amp power supply and must also be electrically grounded in accordance with local codes or, in the absence of local codes, with the National Electrical Code, ANSI/NFPA 70 or the Canadian Electrical Code, CSA C22.1.

### POWER FLUCTUATIONS AND ELECTRICAL NOISE

The water heater's control system requires a source of stable clean electricity for proper operation. Connecting the water heater to a branch circuit that is subject to fluctuations in voltage level or electrical line noise such as EMI (electro magnetic interference) or RFI (radio frequency interference) may cause erratic control system operation and malfunction.

A high quality power supply filter/suppressor such as the Kleen Line model SELF/T-10 Series SC-L or equivalent must be installed if the above conditions exist. Call the technical support phone number listed on the back cover of this manual for more information.

**NOTE:** Malfunctions caused by the power supply and the costs to install power supply filters are not covered under the limited warranty.

### DEDICATED POWER WIRING AND BREAKERS

Dedicated power supply wires, ground wiring and dedicated circuit breakers often prevent electrical line noise and should be considered when installing the water heater.

### POLARITY SENSITIVE

The control system on the water heaters covered in this manual is polarity sensitive; electronic flame sensing requires correct polarity. The control system is programmed to monitor the incoming power supply. If the Hot and Neutral wires in the 120 VAC power supply are reversed, the control system will declare a Fault condition and lock out, heating operation will be disabled until the power supply is correctly wired. The control system will display the "AC Reversed" Fault message on the LCD.

See Electrical Wiring on page 39 for installation instructions.



## MIXING VALVES

⚠ DANGER

Water temperature over 125°F (52°C) can cause severe burns instantly resulting in severe injury or death.

Children, the elderly and the physically or mentally disabled are at highest risk for scald injury.

Feel water before bathing or showering.

Temperature limiting devices such as mixing valves must be installed when required by codes and to ensure safe temperatures at fixtures.

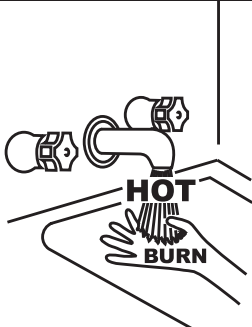

Water heated to a temperature which will satisfy clothes washing, dish washing, and other sanitizing needs can scald and cause permanent injury upon contact. Short repeated heating cycles caused by small hot water uses can cause temperatures at the point of use to exceed the water heater's temperature setting by up to 20°F (11°C).

Some people are more likely to be permanently injured by hot water than others. These include the elderly, children, the infirm and the physically/mentally disabled. Table 6 shows the approximate time-to-burn relationship for normal adult skin. If anyone using hot water provided by the water heater being installed fits into one of these groups or if there is a local code or state law requiring a certain water temperature at the point of use, then special precautions must be taken.

In addition to using the lowest possible temperature setting that satisfies the demand of the application a Mixing Valve should be installed at the water heater (see Figure 8) or at the hot water taps to further reduce system water temperature.

Mixing valves are available at plumbing supply stores. Consult a Qualified Installer or Service Agency. Follow mixing valve manufacturer's instructions for installation of the valves.

**TABLE 6**

Water Temperature	Time to Produce 2nd & 3rd Degree Burns on Adult Skin
180°F (82°C)	Nearly instantaneous
170°F (77°C)	Nearly instantaneous
160°F (71°C)	About 1/2 second
150°F (66°C)	About 1-1/2 seconds
140°F (60°C)	Less than 5 seconds
130°F (54°C)	About 30 seconds
120°F (49°C)	More than 5 minutes

## DISHWASHING MACHINES

All dishwashing machines meeting the National Sanitation Foundation requirements are designed to operate with water flow pressures between 15 and 25 pounds per square inch (103 kPa and 173 kPa). Flow pressures above 25 pounds per square inch (173 kPa), or below 15 pounds per square inch (103 kPa), will result in improperly sanitized dishes. Where pressures are high, a water pressure reducing or flow regulating control valve should be used in the 180°F (82°C) line to the dishwashing machine and should be adjusted to deliver water pressure between these limits.

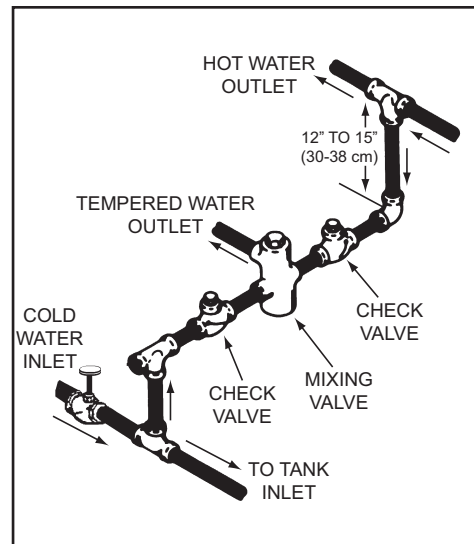

**Figure 8**

The National Sanitation Foundation also recommends circulation of 180°F (82°C) water. Where this is done, the circulation should be very gentle so that it does not cause any unnecessary turbulence inside the water heater. The circulation should be just enough to provide 180°F (82°C) water at the point of take-off to the dishwashing machine.

Adjust flow by throttling a full port ball valve installed in the circulating line on the outlet side of the pump. Never throttle flow on the suction side of a pump. See the Water Piping Diagrams beginning on page 67.

**NOTE:** To comply with NSF Standard 5 installation requirements the bottom of the water heater must be sealed to the floor with a silicone based sealant or elevated 6 inches above the floor.

## CLOSED WATER SYSTEMS

Water supply systems may, because of code requirements or such conditions as high line pressure, among others, have installed devices such as pressure reducing valves, check valves, and back flow preventers. Devices such as these cause the water system to be a closed system.

## THERMAL EXPANSION

As water is heated, it expands (thermal expansion). In a closed system the volume of water will grow when it is heated. As the volume of water grows there will be a corresponding increase in water pressure due to thermal expansion. Thermal expansion can cause premature tank failure (leakage). This type of failure is not covered under the limited warranty. Thermal expansion can also cause intermittent Temperature-Pressure Relief Valve operation: water discharged from the valve due to excessive pressure build up. This condition is not covered under the limited warranty. The Temperature-Pressure Relief Valve is not intended for the constant relief of thermal expansion.

A properly sized thermal expansion tank must be installed on all closed systems to control the harmful effects of thermal expansion. Contact a local plumbing service agency to have a thermal expansion tank installed.

See Water Line Connections on page 40 and the Water Piping Diagrams beginning on page 67.

## TEMPERATURE-PRESSURE RELIEF VALVE

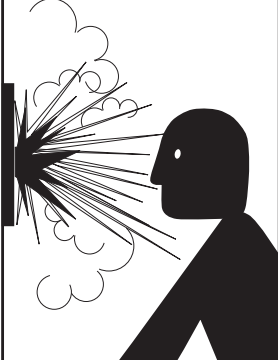
	<b>⚠ WARNING</b>
	<b>Explosion Hazard</b> <ul style="list-style-type: none"><li>• Temperature-Pressure Relief Valve must comply with ANSI Z21.22- CSA 4.4 and ASME code.</li><li>• Properly sized temperature-pressure relief valve must be installed in opening provided.</li><li>• Can result in overheating and excessive tank pressure.</li><li>• Can cause serious injury or death.</li></ul>

This water heater is provided with a properly rated/sized and certified combination Temperature-Pressure Relief Valve (T&P valve) by the manufacturer. The valve is certified by a nationally recognized testing laboratory that maintains periodic inspection of production of listed equipment of materials as meeting the requirements for Relief Valves for Hot Water Supply Systems, ANSI Z21.22 • CSA 4.4, and the code requirements of ASME.

If replaced, the new T&P valve must meet the requirements of local codes, but not less than a combination Temperature-Pressure Relief Valve rated/sized and certified as indicated in the above paragraph. The new valve must be marked with a maximum set pressure not to exceed the marked hydrostatic working pressure of the water heater (150 psi = 1,035 kPa) and a discharge capacity not less than the water heater Btu/hr or kW input rate as shown on the water heater's model rating label.

**NOTE:** In addition to the factory installed Temperature-Pressure Relief Valve on the water heater, each remote storage tank that may be installed and piped to a water heating appliance must also have its own properly sized, rated and approved Temperature-Pressure Relief Valve installed. Call the toll free technical support phone number listed on the back cover of this manual for technical assistance in sizing a Temperature-Pressure Relief Valve for remote storage tanks.

For safe operation of the water heater, the Temperature-Pressure Relief Valve must not be removed from its designated opening nor plugged. The Temperature-Pressure Relief Valve must be installed directly into the fitting of the water heater designed for the relief valve. Install discharge piping so that any discharge will exit the pipe within 6 inches (15.2 cm) above an adequate floor drain, or external to the building. In cold climates it is recommended that it be terminated at an adequate drain inside the building. Be certain that no contact is made with any live electrical part. The discharge opening must not be blocked or reduced in size under any circumstances. Excessive length, over 30 feet (9.14 m), or use of more than four elbows can cause restriction and reduce the discharge capacity of the valve.

No valve or other obstruction is to be placed between the Temperature-Pressure Relief Valve and the tank. Do not connect discharge piping directly to the drain unless a 6" (15.2 cm) air gap is provided. To prevent bodily injury, hazard to life, or property damage, the relief valve must be allowed to discharge water in adequate quantities should circumstances demand. If the discharge pipe is not connected to a drain or other suitable means, the water flow may cause property damage.

## CAUTION

### Water Damage Hazard

- Temperature-Pressure Relief Valve discharge pipe must terminate at adequate drain.

#### T&P Valve Discharge Pipe Requirements:

- Shall not be smaller in size than the outlet pipe size of the valve, or have any reducing couplings or other restrictions.
- Shall not be plugged or blocked.
- Shall not be exposed to freezing temperatures.
- Shall be of material listed for hot water distribution.
- Shall be installed so as to allow complete drainage of both the Temperature-Pressure Relief Valve and the discharge pipe.
- Must terminate a maximum of six inches above a floor drain or external to the building. In cold climates, it is recommended that the discharge pipe be terminated at an adequate drain inside the building.
- Shall not have any valve or other obstruction between the relief valve and the drain.

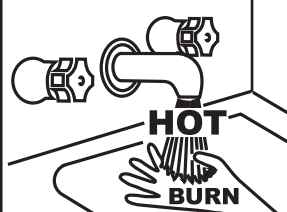
<b>⚠ DANGER</b>	<ul style="list-style-type: none"><li>• Burn hazard.</li><li>• Hot water discharge.</li><li>• Keep clear of Temperature-Pressure Relief Valve discharge outlet.</li></ul>
	

The Temperature-Pressure Relief Valve must be manually operated at least twice a year. Caution should be taken to ensure that (1) no one is in front of or around the outlet of the Temperature-Pressure Relief Valve discharge line, and (2) the water manually discharged will not cause any bodily injury or property damage because the water may be extremely hot. If after manually operating the valve, it fails to completely reset and continues to release water, immediately close the cold water inlet to the water heater, follow the draining instructions in this manual, and replace the Temperature-Pressure Relief Valve with a properly rated/sized new one.

**NOTE:** The purpose of a Temperature-Pressure Relief Valve is to prevent excessive temperatures and pressures in the storage tank. The T&P valve is not intended for the constant relief of thermal expansion. A properly sized thermal expansion tank must be installed on all closed systems to control thermal expansion, see Closed Water Systems and Thermal Expansion on page 14.

If you do not understand these instructions or have any questions regarding the Temperature-Pressure Relief Valve call the toll free number listed on the back cover of this manual for technical assistance.

## CONDENSATE DRAIN

The water heaters covered in this manual are condensing appliances and require a building drain to be located in close proximity to allow the condensate to drain safely.

Condensate drains from the water heater at the exhaust elbow located at the bottom. The field installed condensate drain line must not be elevated above the condensate drain connection on the condensate trap, see Figure 9. If the condensate does not drain properly it will build up in the exhaust (vent) elbow. This will restrict the flow of flue gases and cause the Blocked Exhaust pressure switch to open its contacts. The control system monitors all pressure switches, if the Blocked Exhaust Switch contacts are open the control system will lock out and disable heating operation. The "Blocked Exhaust" Fault message will be displayed on the control system's LCD, see Fault And Alert Conditions beginning on page 57.

**NOTE:** If the "Blocked Exhaust" Fault message is ever displayed on the control system LCD, check the condensate drain first and ensure it is not blocked.

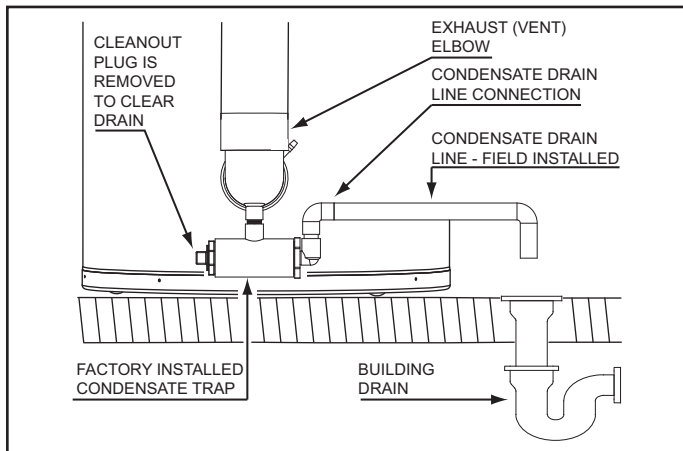



Figure 9

## CONDENSATE DRAIN WATER TRAP

# ! WARNING

Breathing Hazard - Carbon Monoxide Gas



- Ensure a functioning water trap is installed in the condensate drain.
- Gas and carbon monoxide detectors are available.
- Install water heater in accordance with the instruction manual.

Breathing carbon monoxide can cause brain damage or death. Always read and understand instruction manual.

Do not remove the factory installed condensate trap for any reason, see Figure 9. The water heater's vent pipe is under a slight positive pressure. The water trap prevents flue gases from escaping into the installed space. See Condensate Drain Installation on page 36.

## CONDENSATE PH LEVEL

The condensate drains from the water heater's covered in this manual have PH levels between 4.3 and 5.0. Install a commercially available neutralizing kit if required by local codes.

**NOTE:** Lower PH levels are acidic. Do not connect a metal drain line, such as copper, to the water heater for this reason. See Condensate Drain Installation on page 36.

## COMBUSTIBLE MATERIAL STORAGE

# ! WARNING

Fire or Explosion Hazard

- Do not store or use gasoline or other flammable vapors and liquids in the vicinity of this or any other appliance.
- Avoid all ignition sources if you smell gas.
- Do not expose water heater controls to excessive gas pressure.
- Use only the gas shown on the water heater rating label.
- Maintain required clearances to combustibles.
- Keep ignition sources away from faucets after extended periods of non-use.



Read instruction manual before installing, using or servicing water heater.



Keep appliance area clear and free of combustible materials, gasoline and other flammable vapors and liquids.

## CONTAMINATED AIR

# ! WARNING

Breathing Hazard - Carbon Monoxide Gas



- Install water heater in accordance with the Instruction Manual and NFPA 54 or CAN/CSA-B149.1.
- To avoid injury, combustion and ventilation air must be taken from outdoors.
- Do not place chemical vapor emitting products near water heater.

Breathing carbon monoxide can cause brain damage or death. Always read and understand instruction manual.

Corrosion of the flue ways and vent system may occur if air for combustion contains certain chemical vapors. Such corrosion may result in failure and risk of asphyxiation.

Combustion air that is contaminated can greatly diminish the life span of the water heater and water heater components such as hot surface igniters and burners. Propellants of aerosol sprays, beauty shop supplies, water softener chemicals and chemicals used in dry cleaning processes that are present in the combustion, ventilation or ambient air can cause such damage.

Do not store products of this sort near the water heater. Air which is brought in contact with the water heater should not contain any of these chemicals. If necessary, uncontaminated air should be obtained from remote or outdoor sources. The limited warranty is voided when failure of water heater is due to a corrosive atmosphere. (See limited warranty for complete terms and conditions).

If the water heater will be used in beauty shops, barber shops, cleaning establishments, or self-service laundries with dry cleaning equipment, it is imperative that the water heater(s) be installed in a Direct Vent configuration so that all air for combustion is derived directly from the outdoor atmosphere through a sealed intake air pipe. See Venting Installation on page 21.

## AIR REQUIREMENTS

<b>⚠ WARNING</b>	
<b>Breathing Hazard - Carbon Monoxide Gas</b>	
	<ul style="list-style-type: none"><li>• Install water heater in accordance with the Instruction Manual and NFPA 54 or CAN/CSA-B149.1.</li><li>• To avoid injury, combustion and ventilation air must be taken from outdoors.</li><li>• Do not place chemical vapor emitting products near water heater.</li></ul>
Breathing carbon monoxide can cause brain damage or death. Always read and understand instruction manual.	

For safe operation an adequate supply of fresh uncontaminated air for combustion and ventilation must be provided.

An insufficient supply of air can cause recirculation of combustion products resulting in contamination that may be hazardous to life. Such a condition often will result in a yellow, luminous burner flame, causing sooting of the combustion chamber, burners and flue tubes and creates a risk of asphyxiation.

Do not install the water heater in a confined space unless an adequate supply of air for combustion and ventilation is brought in to that space using the methods described in the Confined Space section that follows.

Never obstruct the flow of ventilation air. If you have any doubts or questions at all, call your gas supplier. Failure to provide the proper amount of combustion air can result in a fire or explosion and cause property damage, serious bodily injury or death.

### UNCONFINED SPACE

An Unconfined Space is one whose volume IS NOT LESS THAN 50 cubic feet per 1,000 Btu/hr (4.8 cubic meters per kW) of the total input rating of all appliances installed in the space. Rooms communicating directly with the space, in which the appliances are installed, through openings not furnished with doors, are considered a part of the unconfined space.

Makeup air requirements for the operation of exhaust fans, kitchen ventilation systems, clothes dryers and fireplaces shall also be considered in determining the adequacy of a space to provide combustion, ventilation and dilution air.

### UNUSUALLY TIGHT CONSTRUCTION

In unconfined spaces in buildings, infiltration may be adequate to provide air for combustion, ventilation and dilution of flue gases. However, in buildings of unusually tight construction (for example, weather stripping, heavily insulated, caulked, vapor barrier, etc.) additional air must be provided using the methods described in the Confined Space section that follows.

### CONFINED SPACE

A Confined Space is one whose volume IS LESS THAN 50 cubic feet per 1,000 Btu/hr (4.8 cubic meters per kW) of the total input rating of all appliances installed in the space.

Openings must be installed to provide fresh air for combustion, ventilation and dilution in confined spaces. The required size for the openings is dependent on the method used to provide fresh air to the confined space AND the total Btu/hr input rating of all appliances installed in the space.

### DIRECT VENT APPLIANCES

Appliances installed in a Direct Vent configuration that derive all air for combustion from the outdoor atmosphere through sealed intake air piping are not factored in the total appliance input Btu/hr calculations used to determine the size of openings providing fresh air into confined spaces.

### EXHAUST FANS

Where exhaust fans are installed, additional air shall be provided to replace the exhausted air. When an exhaust fan is installed in the same space with a water heater, sufficient openings to provide fresh air must be provided that accommodate the requirements for all appliances in the room and the exhaust fan. Undersized openings will cause air to be drawn into the room through the water heater's vent system causing poor combustion. Sooting, serious damage to the water heater and the risk of fire or explosion may result. It can also create a risk of asphyxiation.

### LOUVERS AND GRILLES

The free areas of the fresh air openings in the instructions that follow do not take in to account the presence of louvers, grilles or screens in the openings.

The required size of openings for combustion, ventilation and dilution air shall be based on the "net free area" of each opening. Where the free area through a design of louver or grille or screen is known, it shall be used in calculating the size of opening required to provide the free area specified. Where the louver and grille design and free area are not known, it shall be assumed that wood louvers will have 25% free area and metal louvers and grilles will have 75% free area. Non motorized louvers and grilles shall be fixed in the open position.



## FRESH AIR OPENINGS FOR CONFINED SPACES

The following instructions shall be used to calculate the size, number and placement of openings providing fresh air for combustion, ventilation and dilution in confined spaces. The illustrations shown in this section of the manual are a reference for the openings that provide fresh air into confined spaces only. **DO NOT** refer to these illustrations for the purpose of vent installation. See Venting Installation on page 21 for complete venting installation instructions.

### OUTDOOR AIR THROUGH TWO OPENINGS

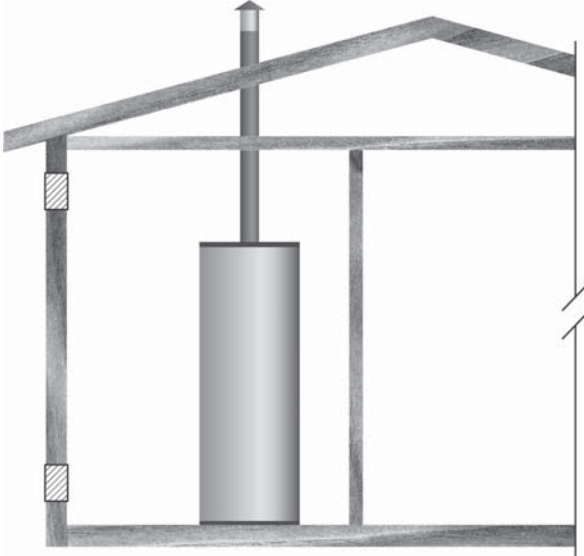

Figure 10

The confined space shall be provided with two permanent openings, one commencing within 12 inches (300 mm) of the top and one commencing within 12 inches (300 mm) of the bottom of the enclosure. The openings shall communicate directly with the outdoors. See Figure 10.

Each opening shall have a minimum free area of 1 square inch per 4,000 Btu/hr (550 mm<sup>2</sup> per kW) of the aggregate input rating of all appliances installed in the enclosure. Each opening shall not be less than 100 square inches (645 cm<sup>2</sup>).

### OUTDOOR AIR THROUGH ONE OPENING

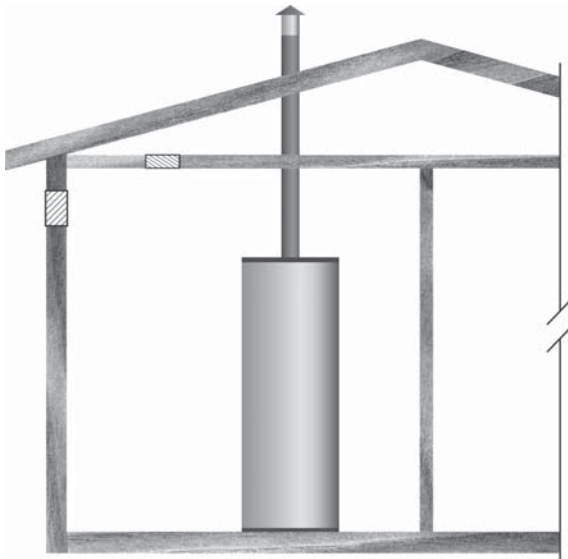

Figure 11

Alternatively a single permanent opening, commencing within 12 inches (300 mm) of the top of the enclosure, shall be provided. See Figure 11. The water heater shall have clearances of at least 1 inch (25 mm) from the sides and back and 6 inches (150 mm) from the front of the appliance. The opening shall directly communicate with the outdoors or shall communicate through a vertical or horizontal duct to the outdoors or spaces that freely communicate with the outdoors and shall have a minimum free area of the following:

1. 1 square inch per 3000 Btu/hr (700 mm<sup>2</sup> per kW) of the total input rating of all appliances located in the enclosure, and
2. Not less than the sum of the areas of all vent connectors in the space.

### OUTDOOR AIR THROUGH TWO HORIZONTAL DUCTS

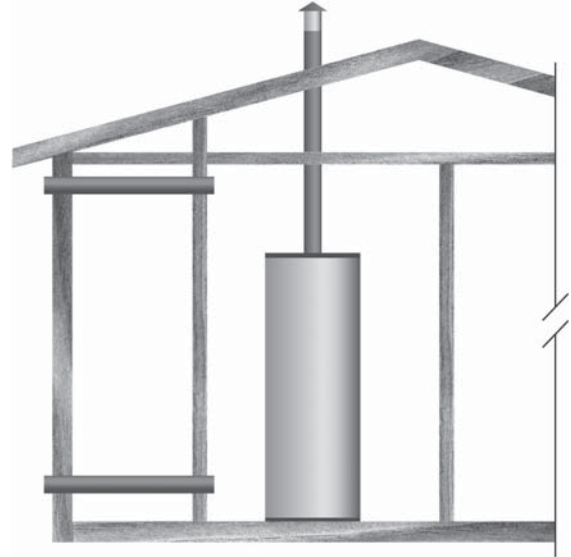

Figure 12

The confined space shall be provided with two permanent horizontal ducts, one commencing within 12 inches (300 mm) of the top and one commencing within 12 inches (300 mm) of the bottom of the enclosure. The horizontal ducts shall communicate directly with the outdoors. See Figure 12.

Each duct opening shall have a minimum free area of 1 square inch per 2,000 Btu/hr (1100 mm<sup>2</sup> per kW) of the aggregate input rating of all appliances installed in the enclosure.

When ducts are used, they shall be of the same cross sectional area as the free area of the openings to which they connect. The minimum dimension of rectangular air ducts shall be not less than 3 inches.



## OUTDOOR AIR THROUGH TWO VERTICAL DUCTS

The illustrations shown in this section of the manual are a reference for the openings that provide fresh air into confined spaces only.

**DO NOT** refer to these illustrations for the purpose of vent installation. See Venting Installation on page 21 for complete venting installation instructions.

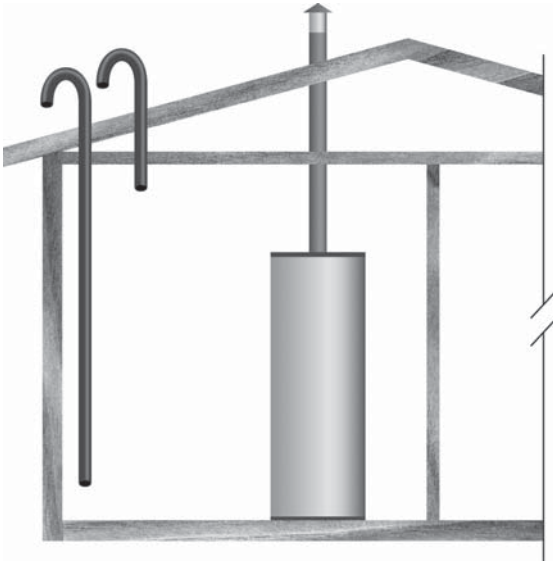

**Figure 13**

The confined space shall be provided with two permanent vertical ducts, one commencing within 12 inches (300 mm) of the top and one commencing within 12 inches (300 mm) of the bottom of the enclosure. The vertical ducts shall communicate directly with the outdoors. See Figure 13.

Each duct opening shall have a minimum free area of 1 square inch per 4,000 Btu/hr (550 mm<sup>2</sup> per kW) of the aggregate input rating of all appliances installed in the enclosure.

When ducts are used, they shall be of the same cross sectional area as the free area of the openings to which they connect. The minimum dimension of rectangular air ducts shall be not less than 3 inches.

## AIR FROM OTHER INDOOR SPACES

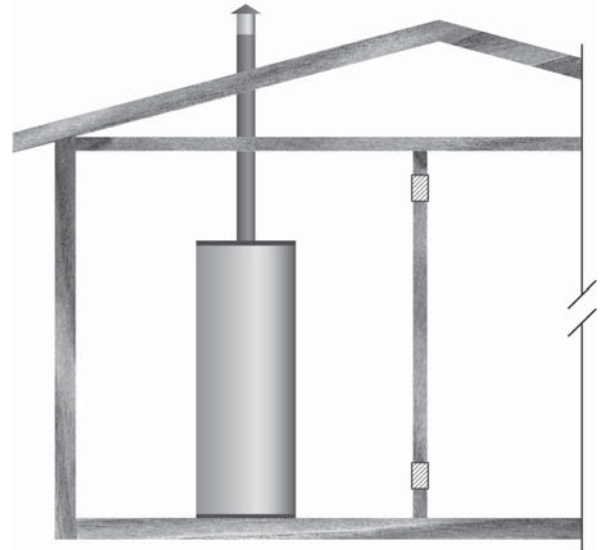

**Figure 14**

The confined space shall be provided with two permanent openings, one commencing within 12 inches (300 mm) of the top and one commencing within 12 inches (300 mm) of the bottom of the enclosure. See Figure 14.

Each opening shall communicate directly with an additional room(s) of sufficient volume so that the combined volume of all spaces meets the criteria for an Unconfined Space.

Each opening shall have a minimum free area of 1 square inch per 1,000 Btu/hr (1100 mm<sup>2</sup> per kW) of the aggregate input rating of all appliances installed in the enclosure. Each opening shall not be less than 100 square inches (645 cm<sup>2</sup>).

# INSTALLATION REQUIREMENTS - COMMONWEALTH OF MASSACHUSETTS

## COMMONWEALTH OF MASSACHUSETTS

For all side wall terminated, horizontally vented power vent, direct vent, and power direct vent gas fueled water heaters installed in every dwelling, building or structure used in whole or in part for residential purposes, including those owned or operated by the Commonwealth and where the side wall exhaust vent termination is less than seven (7) feet above finished grade in the area of the venting, including but not limited to decks and porches, the following requirements shall be satisfied:

### INSTALLATION OF CARBON MONOXIDE DETECTORS

At the time of installation of the side wall horizontal vented gas fueled equipment, the installing plumber or gasfitter shall observe that a hard wired carbon monoxide detector with an alarm and battery back-up is installed on the floor level where the gas equipment is to be installed. In addition, the installing plumber or gasfitter shall observe that a battery operated or hard wired carbon monoxide detector with an alarm is installed on each additional level of the dwelling, building or structure served by the sidewall horizontal vented gas fueled equipment. It shall be the responsibility of the property owner to secure the services of qualified licensed professionals for the installation of hard wired carbon monoxide detectors.

In the event that the side wall horizontally vented gas fueled equipment is installed in a crawl space or an attic, the hard wired carbon monoxide detector with alarm and battery back-up may be installed on the next adjacent floor level.

In the event that the requirements of this subdivision can not be met at the time of completion of installation, the owner shall have a period of thirty (30) days to comply with the above requirements provided that during said thirty (30) day period, a battery operated carbon monoxide detector with an alarm shall be installed.

### APPROVED CARBON MONOXIDE DETECTORS

Each carbon monoxide detector as required in accordance with the above provisions shall comply with NFPA 720 and be ANSI/UL 2034 listed and CSA certified.

### SIGNAGE

A metal or plastic identification plate shall be permanently mounted to the exterior of the building at a minimum height of eight (8) feet above grade directly in line with the exhaust vent terminal for the horizontally vented gas fueled heating appliance or equipment. The sign shall read, in print size no less than one-half (1/2) inch in size, "**GAS VENT DIRECTLY BELOW. KEEP CLEAR OF ALL OBSTRUCTIONS.**"

## INSPECTION

The state or local gas inspector of the side wall horizontally vented gas fueled equipment shall not approve the installation unless, upon inspection, the inspector observes carbon monoxide detectors and signage installed in accordance with the provisions of 248 CMR 5.08(2)(a) 1 through 4.

### EXEMPTIONS

The following equipment is exempt from 248 CMR 5.08(2)(a)1 through 4:

1. The equipment listed in Chapter 10 entitled "Equipment Not Required To Be Vented" in the most current edition of NFPA 54 as adopted by the Board; and
2. Product Approved side wall horizontally vented gas fueled equipment installed in a room or structure separate from the dwelling, building, or structure used in whole or in part for residential purposes.

### MANUFACTURER REQUIREMENTS - GAS EQUIPMENT VENTING SYSTEM PROVIDED

When the manufacturer of Product Approved side wall horizontally vented gas equipment provides a venting system design or venting system components with the equipment, the instructions provided by the manufacturer for installation of the equipment and the venting system shall include:

1. Detailed instructions for the installation of the venting system design or the venting system components; and
2. A complete parts list for the venting system design or venting system.

### MANUFACTURER REQUIREMENTS - GAS EQUIPMENT VENTING SYSTEM NOT PROVIDED

When the manufacturer of a Product Approved side wall horizontally vented gas fueled equipment does not provide the parts for venting the flue gases, but identifies "special venting systems," the following requirements shall be satisfied by the manufacturer:

1. The referenced "special venting system" instructions shall be included with the appliance or equipment installation instructions; and
2. The "special venting systems" shall be Product Approved by the Board, and the instructions for that system shall include a parts list and detailed installation instructions.

A copy of all installation instructions for all Product Approved side wall horizontally vented gas fueled equipment, all venting instructions, all parts lists for venting instructions, and/or all venting design instructions shall remain with the appliance or equipment at the completion of the installation.

# VENTING INSTALLATION

## ⚠️ WARNING

### Breathing Hazard - Carbon Monoxide Gas



- Install vent system in accordance with codes.
- Do not operate water heater if flood damaged.
- Special consideration must be taken with installations above 10,000 feet (3,048 m) refer to high altitude section of this manual.
- Do not operate if soot buildup.
- Do not obstruct water heater air intake with insulating jacket or blanket.
- Do not place chemical vapor emitting products near water heater.
- Gas and carbon monoxide detectors are available.
- Never operate the heater unless it is vented to the outdoors and has adequate air supply to avoid risks of improper operation, fire, explosion or asphyxiation.
- Analyze the entire vent system to make sure that condensate will not become trapped in a section of vent pipe and therefore reduce the open cross sectional area of the vent.

Breathing carbon monoxide can cause brain damage or death.  
Always read and understand the instruction manual.

Never operate the water heater unless it is vented to the outdoors.

The instructions in this section of the manual must be followed to avoid choked combustion or recirculation of flue gases. Such conditions cause sooting of the combustion chamber, burners and flue tubes and creates a risk of asphyxiation.

### GENERAL VENTING INFORMATION

The water heaters covered in this manual are operationally equivalent to Category IV appliances and may be installed in either a Power Vent or Direct Vent configuration.

#### CATEGORY IV APPLIANCE

Category IV appliances operate with a positive vent (exhaust) static pressure and with vent gas temperatures low enough to produce condensate in the vent piping.

#### POWER VENT CONFIGURATION

Power Vent configurations derive all combustion air from the room where they are installed and discharge all flue gases to the outdoor atmosphere through a sealed vent (exhaust) pipe. Power vent configurations have one vent pipe connected to the water heater which can be terminated in a vertical or horizontal arrangement. See Figure 40 and Figure 41 on page 32.

#### DIRECT VENT CONFIGURATION

Direct Vent configurations derive all combustion air directly from the outdoor atmosphere through a sealed intake air pipe and discharge all flue gases to the outdoor atmosphere through a sealed vent (exhaust) pipe. Direct Vent configurations have two pipes connected to the water heater, one vent pipe and one intake air pipe. Direct Vent configurations can be terminated in one of six different arrangements. See Figure 42 on page 32 through Figure 47 on page 33.

### GENERAL VENTING INSTRUCTIONS

These instructions must be followed on all installations.

1. DO NOT install the water heater in a Power Vent configuration unless there is adequate supply of fresh air, see Air Requirements on page 17. If the installation space does not

provide an adequate supply of fresh air the water heater must be installed in a Direct Vent configuration.

2. If the water heater is to be installed in a beauty shop, barber shop, cleaning establishment, a laundry with dry cleaning equipment or any space with contaminated air it is imperative that the water heater(s) be installed in a Direct Vent configuration so that all air for combustion is derived from the outdoor atmosphere.
3. The vent and intake air piping must terminate outdoors.
4. The minimum clearance from combustible materials for the vent (exhaust) and intake air piping shall be 0 inches. Vent piping passing through a combustible wall or ceiling must be a continuous run (no joints).
5. The water heater must be protected from freezing downdrafts during shutdown periods.
6. The vent (exhaust) pipe must not be combined or connected to any other appliance's vent system or chimney.
7. The intake air pipe must not be combined or connected to any other appliance's intake air piping.
8. Locate the water heater where the vent (exhaust) and intake air piping will remain within the maximum equivalent lengths allowed. See Venting Requirements on page 22.
9. Do not install the vent or intake air piping in a manner that will allow water to be trapped in the piping.
10. Vent pipes must be pitched a minimum of a 1/4 inch per foot back to the water heater (to allow drainage of condensate).
11. Do not anchor the vent or intake air pipe directly to framed walls, floors or ceilings unless rubber isolation pipe hangers are used to prevent vibration noise from being transmitted.
12. Use only approved vent/intake air pipe sizes and materials. See Venting Requirements on page 22.
13. Use only factory supplied vent and intake air or concentric terminations. See the Venting Requirements on page 22.
14. Do not locate the vent (exhaust) or intake air terminations where they would be objectionable due to noise at the termination(s). This includes locations close to or across from windows and doors.
15. Direct venting into dead air spaces such as alleys, atriums, and inside corners can cause recirculation of flue gases. Recirculation of flue gases will cause sooting, premature failure of the heat exchanger and icing of the combustion air intake during severe cold weather. To prevent the recirculation of flue gases, maintain as much distance as possible between the intake air and vent terminations.
16. Do not locate the vent termination over a public area where condensate or vapor can cause a nuisance or ice hazard.
17. Ensure the screens in the factory supplied terminations are securely installed to prevent blockage in the vent system.
18. Stress levels in pipe/fittings can be significantly increased by improper installation. If rigid pipe clamps are used to hold the pipe in place, or if the pipe cannot move freely through a wall penetration, the pipe may be stressed, or high thermal stresses may be formed when the pipe heats up and expands. Install accordingly to minimize such stresses.
19. Carefully read the Venting Requirements on page 22 and then proceed to the Venting Installation Sequence on page 23.

## VENTING REQUIREMENTS

### APPROVED MATERIALS

Approved vent and intake air pipe materials that may be used in the United States:

- PVC Schedule 40 (ASTM D 2241 / CSA B181.2, ASTM D 1785 / CSA B137.3)
- CPVC Schedule 40 (ASTM F-411 / CSA B137.6)
- ABS (ASTM D-2661)

Approved vent and intake air pipe materials that must be used in Canada:

- ULC S636 PVC / CPVC

### FIELD SUPPLIED FITTINGS

Field supplied fittings should be equivalent to the piping material being installed. Field installed/supplied fittings will add equivalent feet to the vent or intake air piping as indicated below. All field supplied/installed fittings and piping must be factored into the equivalent feet calculations.

- 90° elbows (short or long radius) are equivalent to 5 linear feet (152 cm) of pipe.
- 45° elbows (short or long radius) are equivalent to 2.5 linear feet (76 cm) of pipe.

### PRIMER AND CEMENT

Tetrahydrofuran (THF) primer should be used to prepare the surfaces of pipe and fittings for solvent welding. If CPVC or ABS pipe and fittings are used, then the proper cement must be used for all joints, including joining the pipe to the factory provided terminations (PVC material). PVC Materials should use ASTM D-2564 Grade Cement; CPVC Materials should use ASTM F-493 Grade Cement and ABS Materials should use ASTM D-2235 Grade Cement.

### PIPE SIZE REQUIREMENTS

The water heaters covered in this manual are certified for the use of 4 and 6 inch pipe for the vent (exhaust) and intake air piping. If the installed equivalent length for the intake air or vent piping will be 70 feet (21.3 m) or less, 4 inch pipe must be used. If the installed equivalent length will be more than 70 feet (21.3 m), 6 inch pipe must be used.

**NOTE:** Install the pipe size required for the installed equivalent length of each pipe independently. IE: If the intake air pipe will be 70 equivalent feet or less and the vent pipe will more than 70 equivalent feet; the intake air pipe must be installed using 4 inch pipe and the vent must be installed using 6 inch pipe.

### MAXIMUM EQUIVALENT LENGTHS

#### Four Inch Pipe

The water heaters covered in this manual are certified to a maximum length of 4 inch pipe for the exhaust venting arrangement of 70 equivalent feet (21.3 m). The certified maximum length of 4 inch pipe for intake air piping is also 70 equivalent feet (21.3 m). IE: On Direct Vent installations both pipes can be up to 70 equivalent feet (21.3 m).

#### Six Inch Pipe

The water heaters covered in this manual are certified to a maximum length of 6 inch pipe for the exhaust venting arrangement of 120 equivalent feet (36.5 m). The certified maximum length of 6 inch pipe for intake air piping is also 120 equivalent feet (36.5 m). IE: On Direct Vent installations both pipes can be up to 120 equivalent feet (36.5 m).

### INTAKE AIR AND VENT PIPE CLEARANCES

The minimum clearance from combustible materials for the vent

(exhaust) and intake air piping shall be 0 inches. Vent or intake air piping passing through a combustible wall or ceiling must be a continuous run (no joints).

### MINIMUM EQUIVALENT LENGTHS

#### Four Inch Pipe

The water heaters covered in this manual are certified to a minimum length of 4 inch pipe for the vent (exhaust) of 15 equivalent feet (4.6 m). There is no minimum equivalent feet requirement for the intake air pipe.

#### Six Inch Pipe

The water heaters covered in this manual are certified to a minimum length of 6 inch pipe for the vent (exhaust) of 70 equivalent feet (21.3 m). There is no minimum equivalent feet requirement for the intake air pipe.

### MAXIMUM NUMBER OF ELBOWS

The vent pipe may have a maximum of six 90° elbows installed. The intake air pipe may have a maximum of six 90° elbows installed. IE: in a Direct Vent configuration each pipe can have up to six (6) 90° elbows installed. Two (2) 45° elbows equal one (1) 90° elbow. Each 90° elbow is equivalent to 5 feet (1.5 m) of linear pipe, 45° elbows are equivalent to 2.5 feet (0.75 m) of linear pipe.

### FACTORY SUPPLIED FITTINGS

The water heater ships with two (2) factory supplied 4 inch terminations (PVC 45° elbows with debris screen). Factory supplied vent and intake air terminations or concentric terminations must be used. Factory supplied terminations and installed fittings (exhaust elbow and intake air connection) add zero equivalent feet to the vent and intake air piping.

**NOTE:** 3 inch intake air and/or vent terminations previously installed on older SUF 130 300/400 model installations must be replaced with factory supplied 4 inch or 6 inch terminations depending on the installed length.

TABLE 7

Number of 90° Elbows Installed	4 Inch Pipe	6 Inch Pipe
	Maximum Feet (Meters)	Maximum Feet (Meters)
One (1)	65 feet (19.8 meters)	115 feet (35.0 meters)
Two (2)	60 feet (18.2 meters)	110 feet (33.5 meters)
Three (3)	55 feet (16.8 meters)	105 feet (32.0 meters)
Four (4)	50 feet (15.2 meters)	100 feet (30.5 meters)
Five (5)	45 feet (13.7 meters)	95 feet (29.0 meters)
Six (6)	40 feet (12.2 meters)	90 feet (27.4 meters)

### 6 INCH EXTENDED VENT TERMINATIONS

When 6 inch intake air or vent pipe is installed using standard terminations, factory supplied 6 inch terminations must be used. Contact your local distributor or call the parts department (phone number listed on the back cover of this manual) to order 6 inch termination(s).

### OPTIONAL CONCENTRIC TERMINATIONS

SUF 130 300 models installed using 4 inch vent/intake air piping use the 4 inch concentric termination. SUF 130 300 models installed using 6 inch vent/intake air piping use the 6 inch concentric termination. SUF 130 400 and 500 models must use the 6 inch concentric termination on all installations.

Contact your local distributor or call the parts department phone number listed on the back cover of this manual to order.

- 4" Concentric Termination Part # 9006328005
- 6" Concentric Termination Part # 9006144005



## VENTING INSTALLATION SEQUENCE

1. Read the General Venting Instructions on page 21 and Venting Requirements on page 22 before proceeding. These instructions and requirements must be followed on all installations.
2. Determine whether the water heater will be installed in a Power Vent or Direct Vent configuration and which vent system arrangement will be used for the installation. See the various venting arrangements on pages 32 and 33.
3. Proceed to the applicable installation instructions that follow; Power Vent Installation or Direct Vent Installation.

## POWER VENT INSTALLATION

1. Read the General Venting Instructions on page 21 and Venting Requirements on page 22 before proceeding. These instructions and requirements must be followed in addition to the instructions below that are specific for Power Vent configurations.
2. Determine which Power Vent arrangement will be used for the installation; vertical or horizontal termination. See Figure 40 and Figure 41 on page 32.
3. Determine the vent pipe size for the installation, see Venting Requirements on page 22.
4. Plan the layout of the vent piping backwards from the termination point outdoors to the water heater. Layout the vent piping to use a minimum of pipe and elbows.
5. Install the termination first.

If the vent piping will terminate vertically, through a roof, see Vertical Termination Installation on page 24.

If the vent piping will terminate horizontally, through a sidewall, see Sidewall Termination Installation on page 26.

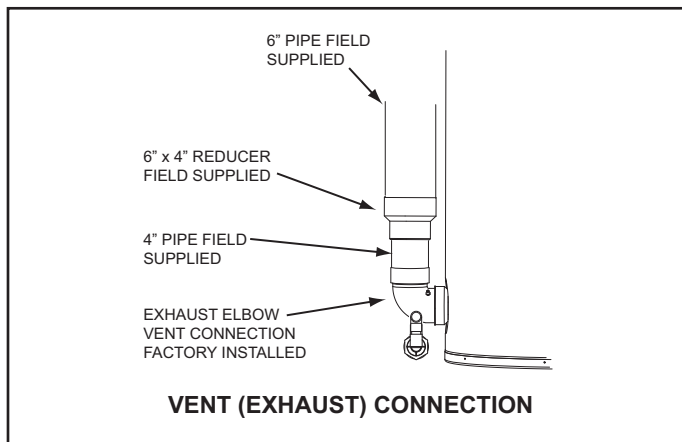

Figure 15

6. When installation of the termination is complete install necessary piping and fittings to route the vent piping back to the water heater.
7. The vent pipe must be supported properly to avoid bending or failure. The water heater manufacturer recommends that the vent pipe be supported every 5 feet (152 cm) of vertical run and every 3 feet (91 cm) of horizontal run.
8. Do not install the vent piping in a manner that will allow water to be trapped in the piping.
9. All vent (exhaust) pipes must be pitched a minimum of a 1/4 inch per foot back to the water heater (to allow drainage of condensate).
10. If installing 4 inch vent pipe connect the vent pipe to the

exhaust elbow on the water heater.

11. If installing 6 inch pipe transition to 4 inch pipe as shown in Figure 15. The field installed 4" pipe between the exhaust elbow and the 6" x 4" reducer coupling should be 18 inches (45 cm) or less in length.

## DIRECT VENT INSTALLATION

1. Read the General Venting Instructions on page 21 and Venting Requirements on page 22 before proceeding. These instructions and requirements must be followed in addition to the instructions below that are specific for Direct Vent configurations.
2. Determine which Direct Vent arrangement will be used for the installation. There are six (6) Direct Vent arrangement options, see pages 32 and 33.
3. Determine vent and intake air pipe size to be used for the installation; see Venting Requirements on page 22.
4. Plan the layout of the vent and intake air piping backwards from the termination point outdoors to the water heater. Layout the vent and intake air piping to use a minimum of pipe and elbows.
5. Install the terminations first.

If standard terminations are being used and the intake air or vent piping will terminate vertically, through a roof, see Vertical Termination Installation on page 24.

If standard terminations are being used and the intake air or vent piping will terminate horizontally, through a sidewall, see Sidewall Termination Installation on page 26.

If a concentric termination(s) will be used see Concentric Termination Installation on page 27.

6. When installation of the termination(s) is complete Install necessary piping and fittings to route the intake air and vent piping back to the water heater.
  7. The intake air and vent piping must be supported properly to avoid bending or failure. The water heater manufacturer recommends that the vent and intake air piping be supported every 5 feet (152 cm) of vertical run and every 3 feet (91 cm) of horizontal run.
  8. Do not install the vent or intake air piping in a manner that will allow water to be trapped in the piping.
  9. A field supplied condensate Tee fitting and drain hose should be installed in the intake air piping near the water heater in colder climates with heavy snow accumulations and in areas that regularly experience high humidity. The drain hose should be routed to an adequate floor drain separate from any other condensate drains. See Figure 16 on page 24.
- NOTE:** Snow being pulled into the intake air piping and then melting can lead to excessive amounts of water accumulation and damage water heater components. Warm, humid outdoor air can lead to excessive condensation inside the intake air piping and may also damage water heater components.
10. All vent (exhaust) pipes must be pitched a minimum of a 1/4 inch per foot back to the water heater (to allow drainage of condensate).
  11. If installing 4 inch vent pipe connect the vent pipe to the exhaust elbow on the water heater.
  12. If installing 6 inch vent pipe transition to 4 inch pipe at the exhaust elbow on the water heater as shown in Figure 15. The field installed 4" pipe between the exhaust elbow and the 6" x 4" reducer coupling should be 18 inches (45 cm) or less in length.



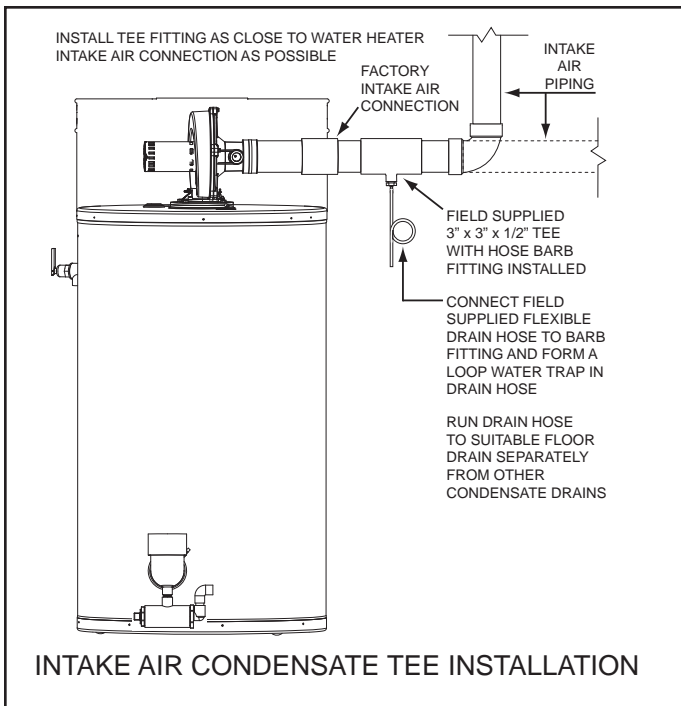
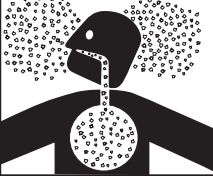

Figure 16

- Ensure the Balance Plate and Intake Air Screen on the Intake Air Connection are both removed before connecting the intake air pipe to the water heater, see Figure 17.

## ⚠ WARNING

### Breathing Hazard - Carbon Monoxide Gas



- Do not obstruct water heater air intake.
- Gas and carbon monoxide detectors are available.
- Install water heater in accordance with the instruction manual.

Breathing carbon monoxide can cause brain damage or death. Always read and understand instruction manual.

**NOTE:** Do not leave the screen inside the Intake Air connection in Direct Vent installations. Once the intake air pipe is installed the screen will be hidden from view and may become clogged with debris over time. This will cause improper combustion.

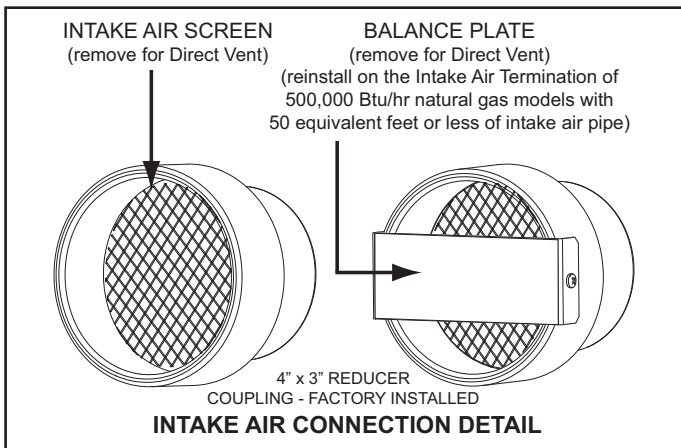

Figure 17

- SUF 130 500 NATURAL GAS MODELS ONLY: install the balance plate (removed in the previous step) on the Intake Air Termination if the installed equivalent length of the intake air pipe will be 50 feet or less. Discard the balance plate for all other models or if the installed equivalent length of the intake air pipe will be more than 50 feet. See Figure 17.
- If installing 4 inch intake air pipe connect the intake air pipe to the intake air connection on the water heater.
- If installing 6" intake air pipe transition to 4" pipe at the intake air connection on the water heater as shown in Figure 18. The field installed 4" pipe between the intake air connection and the 6" x 4" reducer coupling should be 18 inches (45 cm) or less in length.

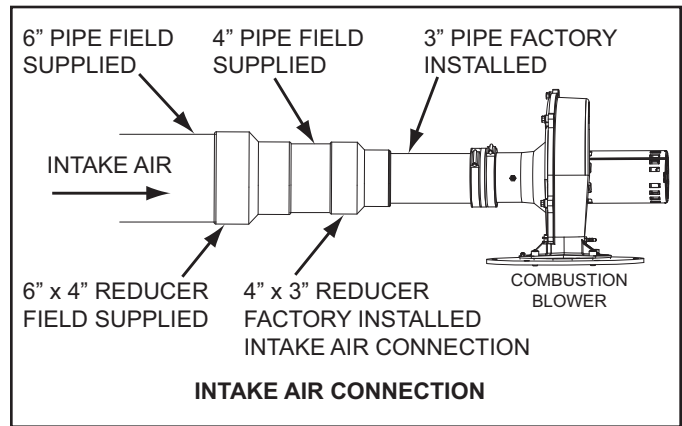

Figure 18

### VERTICAL TERMINATION INSTALLATION

- Determine the location for the termination(s).
- If installing only the vent (exhaust) piping in a Power Vent configuration vertically through the roof; ensure that all exterior vertical clearance requirements shown in Figure 19 and Figure 20 on page 25 are being maintained. These clearances and those cited by local and national codes must be maintained.
 

**NOTE:** On flat roof installations the vent termination must be a minimum of 24 inches (60 cm) above any parapet, vertical wall or structure within 10 feet (3 m) horizontally. See Figure 20 on page 25.
- If installing both intake air and vent piping in a Direct Vent configuration vertically through the roof; ensure that all exterior vertical clearance requirements shown in Figure 19 and Figure 20 on page 25 are being maintained. These clearances and those cited by local and national codes must be maintained.

**NOTE:** On flat roof installations the intake air and the vent terminations must be a minimum of 24 inches (60 cm) above any parapet, vertical wall or structure within 10 feet (3 m) horizontally. See Figure 20 on page 25.

- If installing only vent piping in a Power Vent configuration vertically through the roof the following instructions must be followed:

The vent termination must be oriented facing downward as shown in Figure 19 and Figure 20 on page 25.

The bottom edge of the vent termination must be a minimum of 12 inches (30 cm), 18 inches (45 cm) in Canada, above the average or expected snow level as shown in Figure 19 on page 25.

- If installing both intake air and vent piping in a Direct Vent

configuration vertically through the roof the following instructions must be followed:

The intake air and vent pipes must penetrate the same side of the roof as shown in Figure 21 on page 25.

The intake air and vent terminations must be oriented facing downward and in the same direction as shown in Figure 21 on page 25.

The intake air and vent terminations must have a minimum separation of 24" (61 cm) measured on center line as shown in Figure 21 on page 25. In colder climates this separation should be increased to at least 48 inches (122 cm).

The bottom edge of the intake air and vent terminations must be a minimum of 12 inches (30 cm), 18 inches (45 cm) in Canada, above the average or expected snow level as shown in Figure 19 and Figure 21 on page 25.

- When the intake air and/or vent piping from multiple water heaters will terminate in the same location the vent terminations can be grouped together in close proximity 0 inches/touching. Intake air terminations can also be grouped together in close proximity 0 inches/touching.

The distance between the closest vent and intake air terminations must be a minimum of 24 inches (61 cm) as shown in Figure 21. In colder climates this separation should be increased to at least 48 inches (122 cm).

- Cut a 5 inch (13 cm) diameter hole for 4 inch pipe or 7 inch (18 cm) diameter hole for 6 inch pipe where the pipe(s) will pass through the roof.

**NOTE:** Beware of concealed wiring and piping when cutting through the roof.

- Suspend the pipe(s) through center of hole using field supplied metal strapping or equivalent support materials as shown in Figure 19.

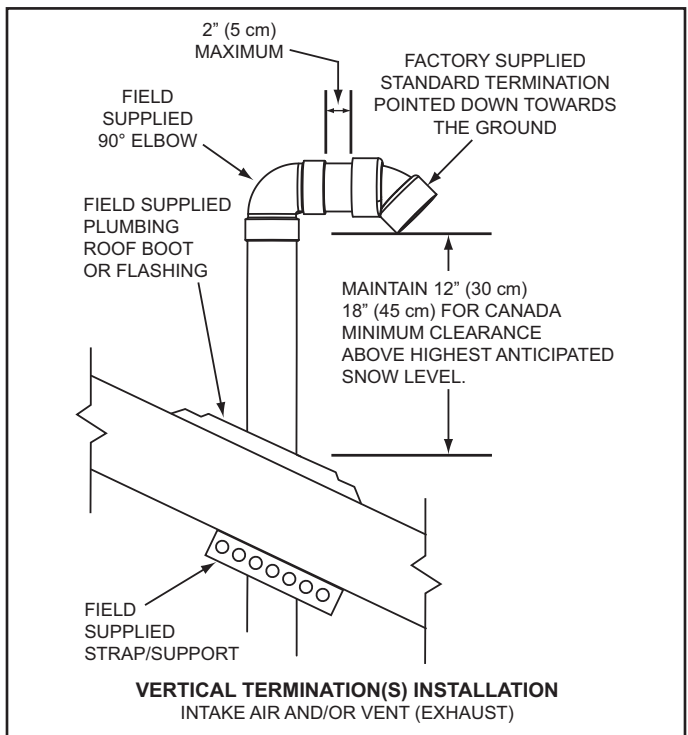

Figure 19

- Slide a roof boot or equivalent flashing over the pipe and secure roof boot or equivalent flashing to roof (see Figure 19) and seal around the flashing.

- Install the factory supplied intake air and/or vent termination(s) using field supplied pipe and one field supplied 90° elbow as shown in Figure 19. The short section of pipe that connects between the field supplied 90° elbow and the factory supplied termination must not be excessive in length. The exposed portion of this pipe shall be no more than 2 inches (5 cm), see Figure 19.

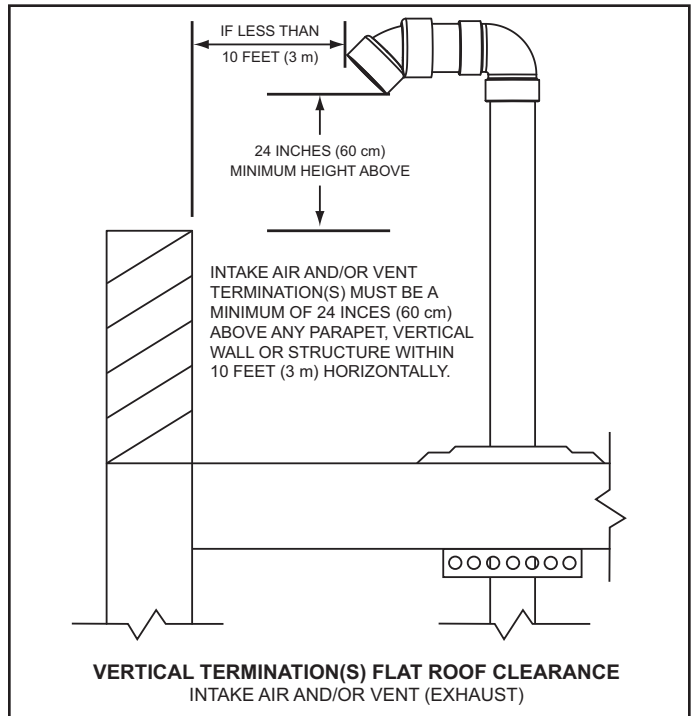

Figure 20

- Return to Power Vent Installation on page 23 or Direct Vent Installation on page 23 to complete the installation of the intake air and/or vent piping between the termination(s) and the water heater.

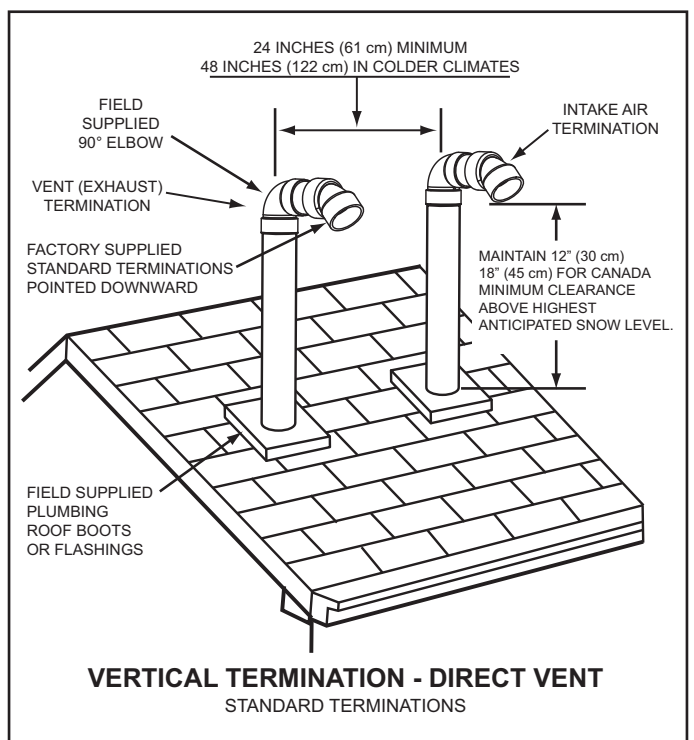

Figure 21

## SIDEWALL TERMINATION INSTALLATION

1. Determine the location for the termination(s).
2. If installing only vent (exhaust) piping in a Power Vent configuration through a sidewall; ensure that all exterior sidewall clearance requirements for the termination, shown in Figure 48 on page 34, are being maintained. These clearances and those cited by local and national codes must be maintained.
3. If installing both intake air and vent piping in a Direct Vent configuration through a sidewall; ensure that all exterior sidewall clearance requirements for the terminations, shown in Figure 49 on page 35, for the vent and intake air termination are being maintained. These clearances and those cited by local and national codes must be maintained.
4. If installing both an intake air and vent termination in a Direct Vent configuration through a sidewall there must be a minimum of 24 inches (61 cm) separation, measured on vertical center line, between the intake air and vent terminations, see Figure 22.

**NOTE:** In colder climates this separation should be increased to at least 48 inches (122 cm) between the intake air and vent termination or any other appliance vent that discharges moisture-laden air such as clothes dryers. This will reduce possibility of frost over from side winds blowing exhaust vapors to the intake air termination and is recommended for Canadian installations.

5. If installing both intake air and vent terminations in a Direct Vent configuration through a sidewall the intake air and vent terminations must be installed at the same elevation measured on horizontal center line - see Figure 22.

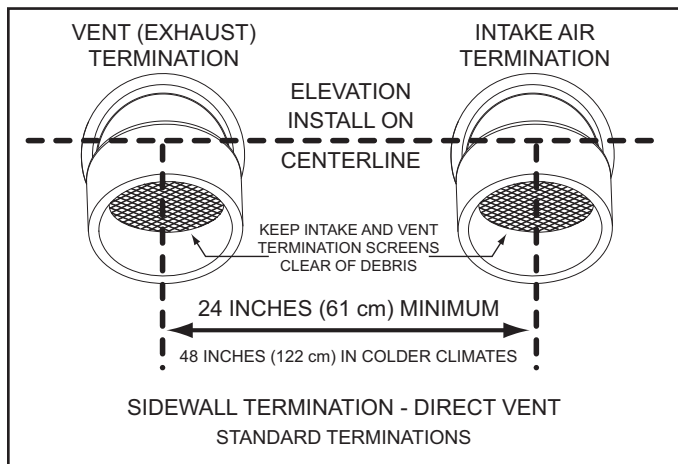

Figure 22

6. When the intake air and/or vent piping from multiple water heaters will terminate at the same location through a sidewall, the vent terminations can be grouped together in close proximity - 0 inches/touching. The intake air terminations can also be grouped together in close proximity - 0 inches/touching.

However, the distance between the closest vent and intake air terminations must be a minimum of 24 inches (61 cm). In colder climates this separation should be increased to at least 48 inches (122 cm). See Figure 22.

7. Cut a 5 inch (13 cm) diameter hole for 4 inch pipe or 7 inch (18 cm) diameter hole for 6 inch pipe where the pipe(s) will pass through the wall.

**NOTE:** Beware of concealed wiring and piping when cutting through the wall.

8. Cut a length(s) of pipe being installed 3.5 inches (8.9 cm) to 9.5 inches (24.1 cm) longer than the wall thickness at the opening. See Figure 23.

**NOTE:** Vent Termination – exhaust gases of this water heater are less than 140°F. In cold climates water vapor in the exhaust gases will condense into a cloud of vapor where the vent exits the building. This vapor can gradually discolor exterior building surfaces. The vent termination should be located where this vapor cloud and potential discoloration are not a concern. Extending the exposed vent piping up to a maximum of 6 inches (15.2 cm) from the wall helps vapor from being trapped along a building's face. To avoid this problem, the vent can also be terminated vertically through the roof, see Vertical Termination Installation on page 24.

9. Cement the intake air and/or vent termination to the section(s) of pipe cut to length in the above Step.
10. Slide the included metal wall plate(s) over the pipe(s) to stop against the intake air and/or vent termination. Place some silicone caulking (field supplied) on the back of the wall plate(s) to secure it to the wall.
11. Working from outside, slide the pipe and termination(s) assembled in the above steps through the wall. Ensure the termination(s) is pointed down towards the ground. See Figure 23.

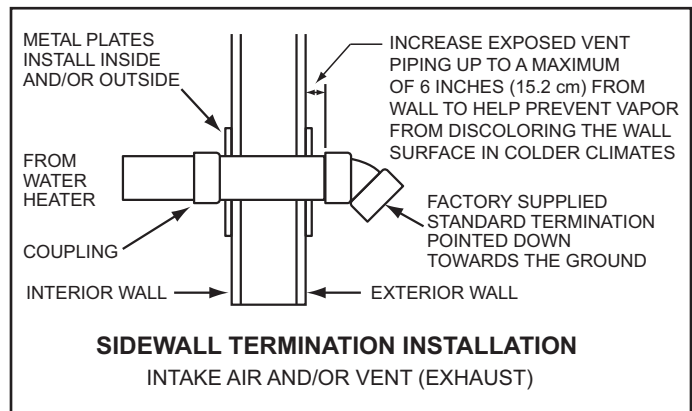

Figure 23

12. Place a bead of silicone caulking (field supplied) around the gap between the installed pipe(s) and the wall. Apply enough to fill the gap between the pipe(s) and wall.
13. Press the wall plate flush against the outside wall.
14. Working from the inside apply enough silicone caulking on the back of the interior wall plate(s) to hold it in place and slide the wall plate over the installed pipe(s).
15. Install a coupling to the end of the pipe(s) inside the building. Before the silicone caulking has time to completely set go outside the building and ensure the termination(s) is still pointing down towards the ground. See Figure 23.
16. Return to Power Vent Installation on page 23 or Direct Vent Installation on page 23 to complete the installation of the intake air and/or vent piping between the termination(s) and the water heater.

## CONCENTRIC TERMINATION INSTALLATION

1. Determine which concentric termination will be installed. SUF 130 300 models installed using 4 inch vent/intake air piping use the 4 inch concentric termination. SUF 130 300 models installed using 6 inch vent/intake air piping use the 6 inch concentric termination. SUF 130 400 and 500 models must use the 6 inch concentric termination on all installations, see Venting Requirements on page 22

2. Determine the location for the termination.

**NOTE:** Roof termination is preferred since it is less susceptible to damage, has reduced chances to intake contaminants and vent vapors are less visible.

3. When installing a concentric termination vertically through the roof; ensure that all exterior vertical clearance requirements for the concentric termination, shown in Figure 27 on page 28 and Figure 30 on page 29, are being maintained. These clearances and those cited by local and national codes must be maintained.

4. When installing a concentric termination vertically through a flat roof, the termination's vent cap must be a minimum of 10 feet (3 m) away from any parapet, vertical wall or structure as shown in Figure 24 and Figure 25.

**NOTE:** If this required distance to a parapet, vertical wall or structure cannot be maintained, standard terminations must be used. See Vertical Termination Installation on page 24

5. When installing a concentric termination through a sidewall; ensure that all exterior sidewall clearance requirements for the termination, shown in Figure 49 on page 35, are being maintained. These clearances and those cited by local and national codes must be maintained.

6. When installing multiple concentric terminations vertically through a roof or horizontally through a sidewall ensure the required clearances between terminations and groupings of multiple terminations are maintained. See pages 30 and 31 for more information.

7. Cut a 5 inch (13 cm) diameter hole for 4 inch concentric terminations or 7 inch (18 cm) diameter hole for 6 inch concentric terminations where they will pass through the wall or roof.

**NOTE:** Beware of concealed wiring and piping when cutting through the wall or roof.

8. When installing multiple concentric terminations vertically through the roof in the same location the termination caps for all concentric terminations must be at the same height measured from ground. See Multiple Concentric Termination Arrangements on page 31.

9. Determine if the concentric termination will need to be shortened or lengthened to accommodate required clearances or to ensure all vent caps are at the same height when installing multiple terminations vertically through the roof in the same location.

See Figure 26 on page 28 and Figure 29 on page 29 for the maximum and minimum lengths allowed for the 4 inch and 6 inch concentric terminations.

When extending the length of a concentric termination **DO NOT** use couplings. The use of couplings will restrict flow through the termination and may cause improper combustion. The termination's intake air and vent pipes must be replaced with longer sections of the same pipe material when extending the length of the termination.

Use only SDR-26 pipe to extend the 4 inch concentric

termination. Use only Schedule 40 PVC to extend the 6 inch concentric termination.

When shortening the length of the termination carefully measure and cut the larger (intake air) pipe first. Cut the same amount of pipe off of the smaller (vent) pipe.

10. Depending on which termination(s) is being installed go to 4 Inch Concentric Termination Installation on page 28 or 6 Inch Concentric Termination Installation on page 29.

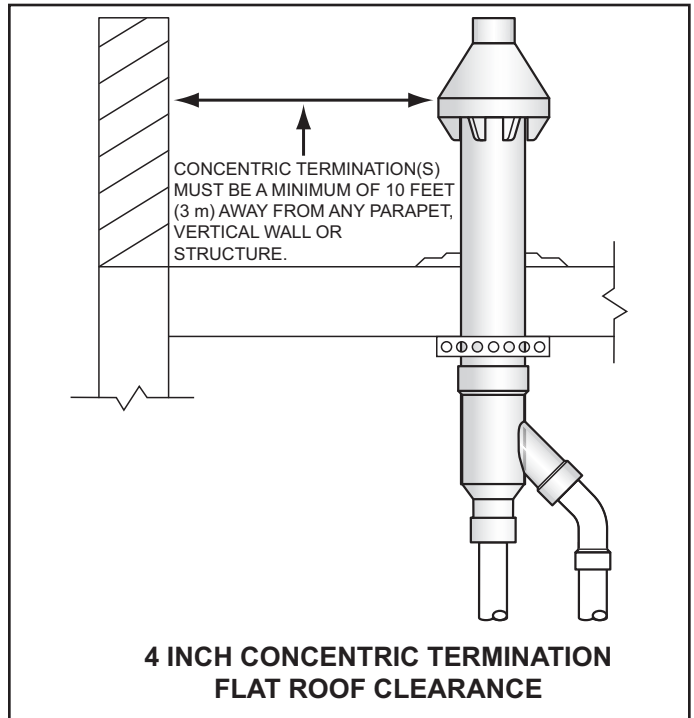

Figure 24

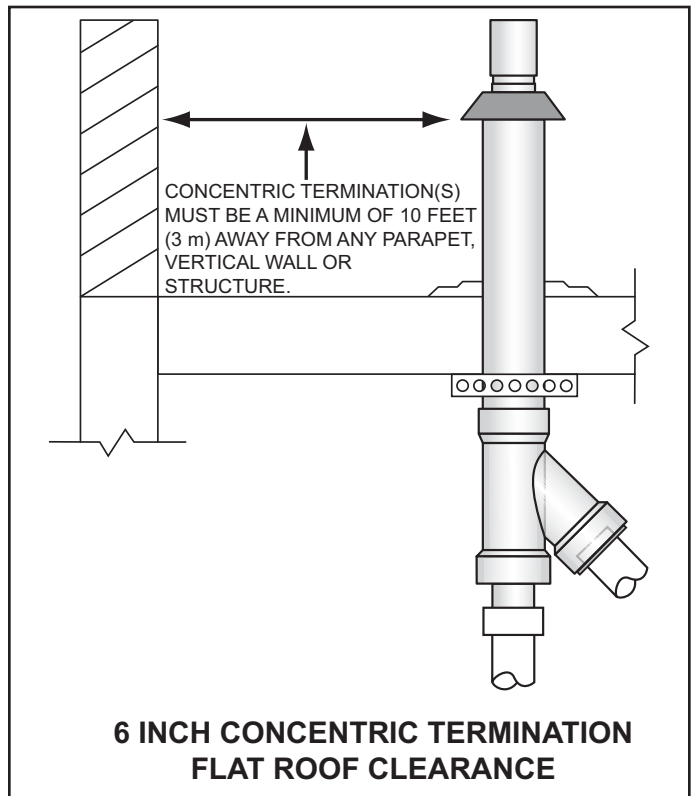
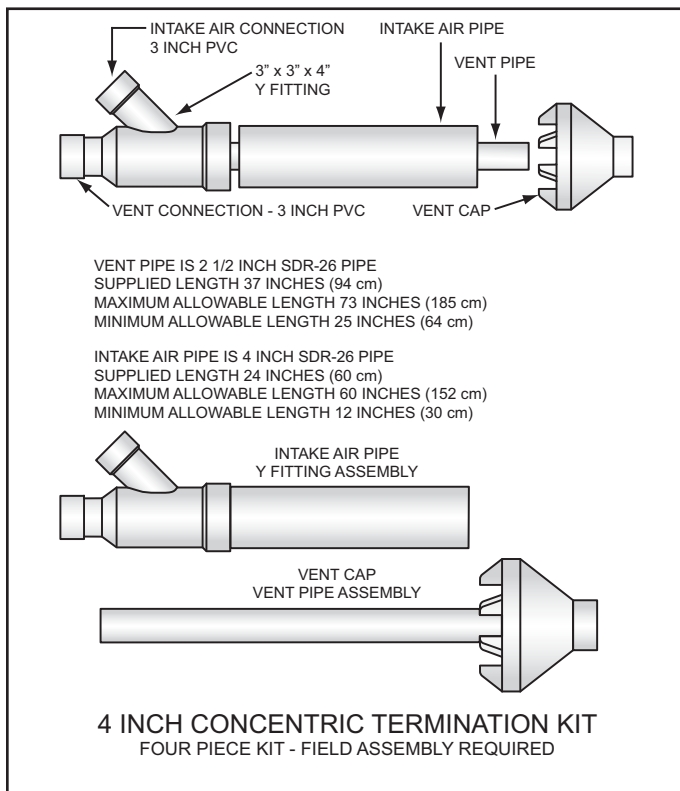

Figure 25



## 4 INCH CONCENTRIC TERMINATION INSTALLATION



**Figure 26**

Assemble and install the 4 inch concentric termination. Refer to Figure 26, Figure 27 and Figure 28 for these instructions:

1. Cement the Y fitting to the larger diameter intake air pipe.
2. Slide the intake air pipe and Y fitting assembly from inside the building through the hole cut for the termination in the roof or sidewall. Ensure no foreign materials such as insulation accumulate inside the assembly.
3. Secure the intake air Y fitting assembly using field supplied metal strapping or equivalent support materials.
4. On installations installed through the roof slide a field supplied plumbing boot or roof flashing over the intake air Y fitting assembly and secure it to the roof.
5. Seal around the plumbing boot or roof flashing.
6. Cement the vent cap onto the vent pipe. Alternately a field-supplied stainless steel screw may be used to secure the 2 components together when field disassembly is desired for cleaning. A pilot hole must be drilled for the screw to prevent damage/cracking of the vent cap and/or vent pipe.
7. Install the vent cap/vent pipe assembly into the intake air Y fitting assembly, Ensure small diameter vent pipe is cemented and bottomed in the Y fitting.
8. Connect the intake air and vent piping from the water heater to the 4 inch concentric termination using field supplied 4" x 3" reducer couplings as needed.
9. Return to Direct Vent Installation on page 23 to complete the installation of the intake air and vent piping between the concentric termination and the water heater.

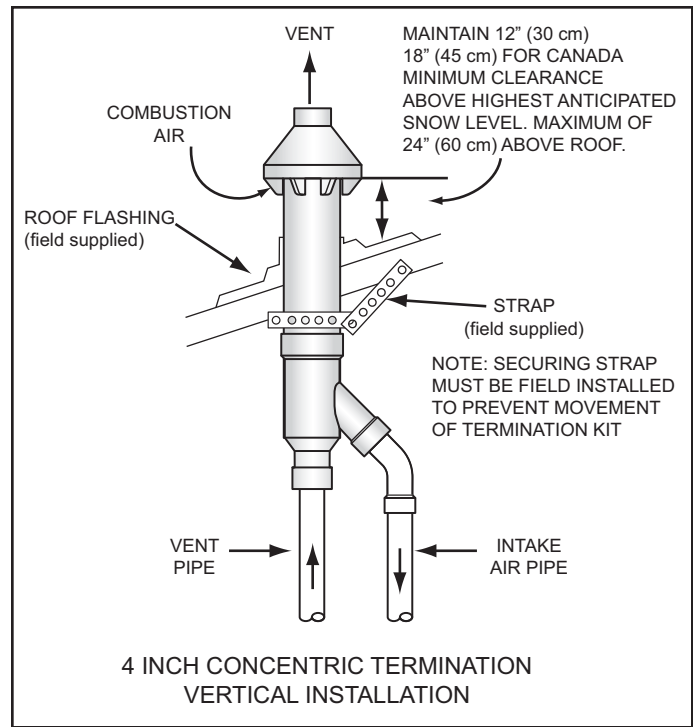

**Figure 27**

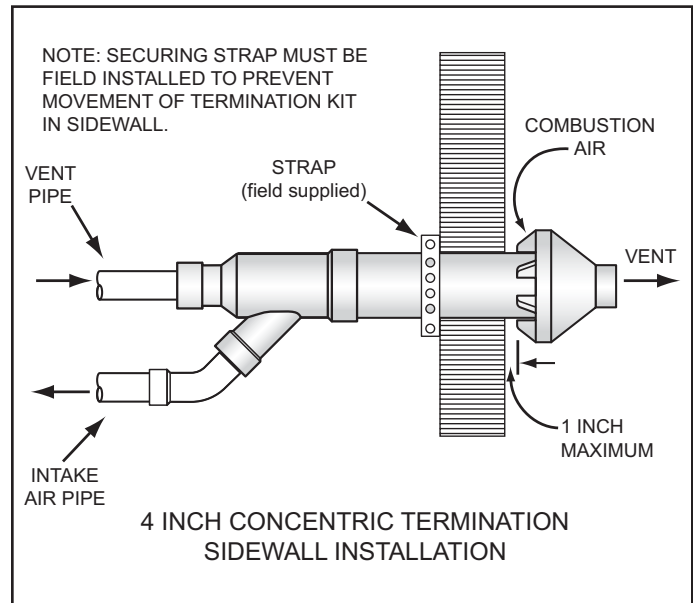

**Figure 28**



## 6 INCH CONCENTRIC TERMINATION INSTALLATION

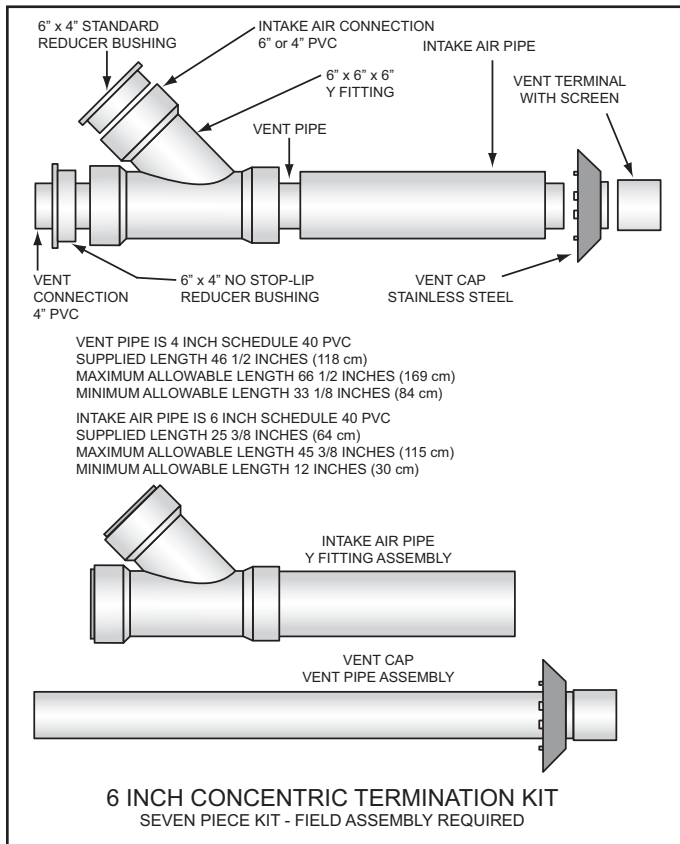
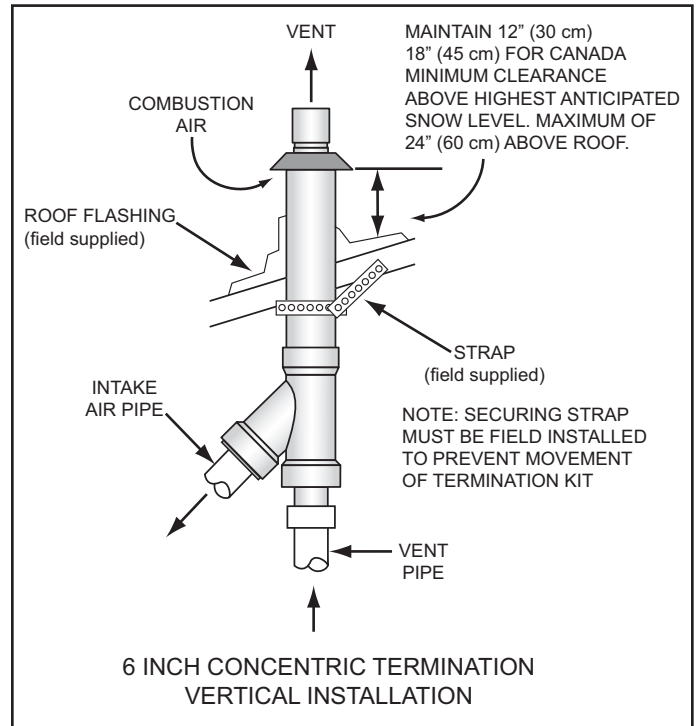

**Figure 29**

Assemble and install the 6 inch concentric termination. Refer to Figure 29, Figure 30 and Figure 31 for these instructions:

1. Cement the Y fitting to the larger diameter intake air pipe.
2. Cement the 6" x 4" no stop-lip reducer bushing into the straight (vent) end of the Y fitting.
3. If the intake air piping being installed is 4 inch pipe, cement the 6" x 4" standard reducer bushing into the angle (intake air) end of the Y fitting as shown in Figure 29.
4. If the intake air piping being installed is 6 inch pipe discard the 6" x 4" standard reducer bushing. The 6 inch intake air piping will connect directly to the angle end of the Y fitting.
5. Slide the intake air Y fitting assembly from inside the building through the hole cut for the termination in the roof or sidewall. Ensure no foreign materials such as insulation accumulate inside the assembly.
6. Secure the intake air Y fitting assembly using field supplied metal strapping or equivalent support materials.
7. On installations installed through the roof slide a field supplied plumbing boot or roof flashing over the intake air Y fitting assembly and secure it to the roof.
8. Seal around the plumbing boot or roof flashing.
9. Slide the steel vent cap onto the 4 inch vent pipe and cement the vent terminal to the end of the vent pipe.
10. Slide the vent cap back up the vent pipe until it touches the vent terminal. Secure the vent cap to the vent pipe using field supplied stainless steel screws. Pilot holes must be drilled for the screws to prevent damage/cracking of the vent pipe. Apply water proof silicone sealant between the vent cap and the terminal.

11. Push the vent cap/vent pipe assembly into the intake air Y fitting assembly until the vent cap seats properly on the large diameter intake air pipe. Ensure the vent pipe is cemented to the no stop-lip reducer bushing previously installed in the Y fitting. Secure the vent cap to intake air pipe with field supplied stainless steel screws. Install the screws through the pre-drilled holes in the vent cap brackets. Pilot holes for the screws must be drilled in the intake air pipe to prevent damage/cracking.



**Figure 30**

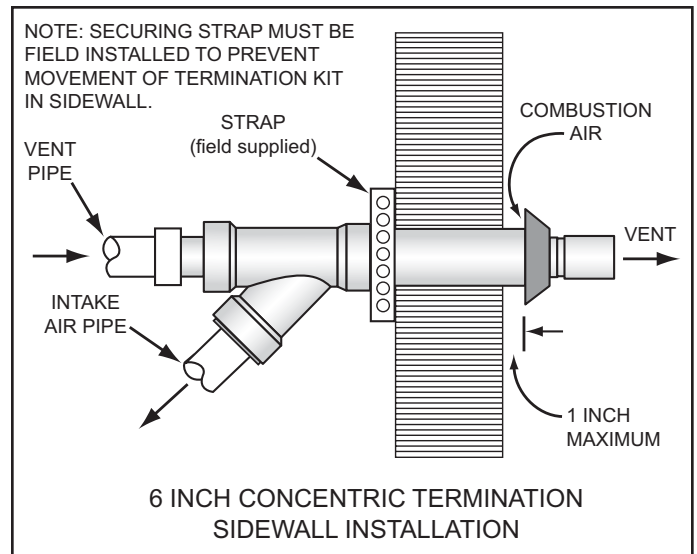

**Figure 31**

12. Connect the intake air and vent piping from the water heater to the 6 inch concentric termination. Use field supplied 4 inch couplings or 6" x 4" reducer couplings as needed.
13. Return to Direct Vent Installation on page 23 to complete the installation of the intake air and vent piping between the concentric termination and the water heater.

### MULTIPLE CONCENTRIC TERMINATION CLEARANCES

When installing multiple concentric terminations vertically through a roof or horizontally through a sidewall ensure the required clearances (separation) between terminations are maintained. Ensure multiple terminations are arranged or grouped as required.

**NOTE:** These clearances must be maintained to prevent the recirculation of vent (exhaust) gases to the intake air. Clearances are measured between the edges of the concentric termination caps.

When installing multiple concentric terminations through a roof or through a sidewall the clearances shown in Figure 32 must be maintained.

See Multiple Concentric Termination Arrangements on page 31.

#### Close Proximity & Standard Clearance

1. The clearance between multiple termination caps must be 0 inches (touching) to a maximum of 2 inches (5 cm), dimension A - Figure 32, when installing concentric terminations in close proximity. See Figure 37 on page 31.
2. The clearance between multiple termination caps must be increased to a minimum of 24 inches (61 cm), dimension B - Figure 32, when installation in close proximity (above) is not possible. This is the standard clearance.

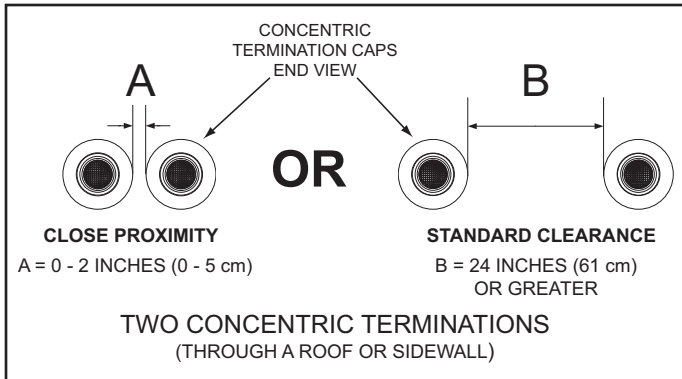

Figure 32

#### Three Concentric Terminations

1. When installing three concentric terminations through a roof or through a sidewall the third termination may be installed in close proximity as indicated by dimension A in Figure 33.
2. If close proximity installation of the third termination is not possible the third termination may be installed as indicated by dimension B in Figure 33.

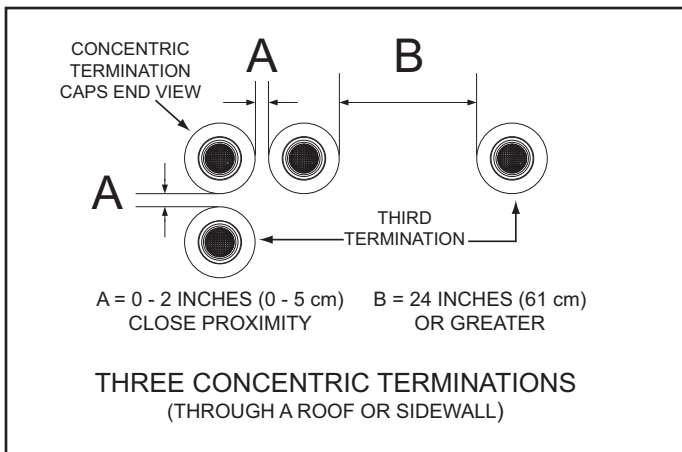

Figure 33

#### Four Concentric Terminations

1. When installing four concentric terminations through a roof or through a sidewall in close proximity they may be arranged into stacked rows of two as shown in Figure 34 or lateral rows of two as shown in Figure 35.
2. Four is the maximum number of concentric terminations that may be installed in a group where all terminations are in close proximity as shown in Figure 34.

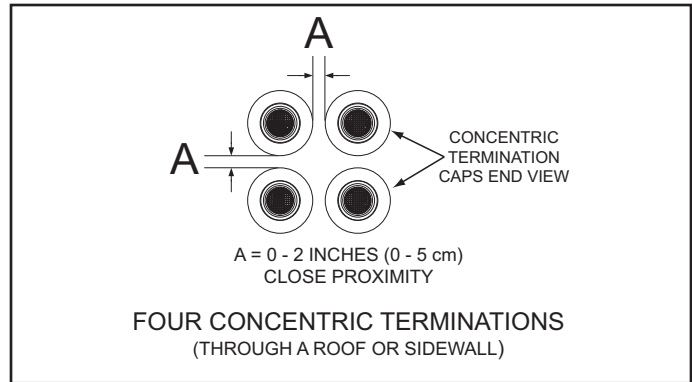

Figure 34

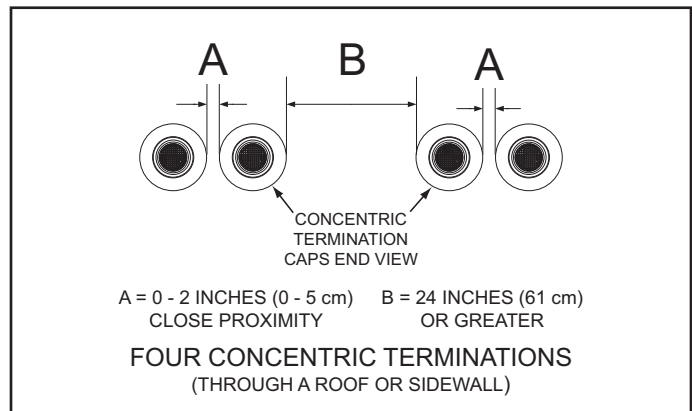

Figure 35

#### Groups Of Terminations

1. When installing multiple groups of concentric terminations through a roof or through a sidewall in close proximity they can be installed into stacked groups of four as shown in Figure 36. Lateral groups of four as shown in Figure 35 may be a more convenient installation arrangement for multiple groups depending on available space.

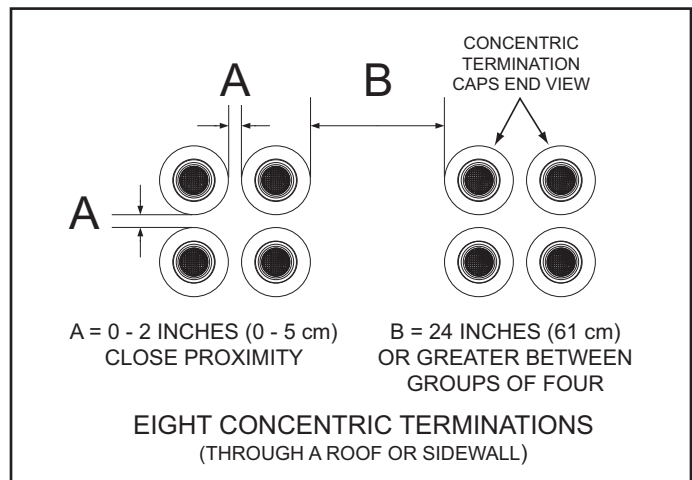

Figure 36

### MULTIPLE CONCENTRIC TERMINATION ARRANGEMENTS

The illustrations on this page show some of the installation arrangements for multiple concentric terminations that are allowed.

See Multiple Concentric Termination Clearances on page 30 for detailed information on clearances and additional arrangement options.

**NOTE:** When multiple concentric terminations are installed through a roof in the same location all termination caps must be at the same height measured from the ground.

#### Two Concentric Terminations

Two concentric terminations may be installed in close proximity as shown in Figure 37 or with standard clearances when this arrangement is not possible. See Figure 32 on page 30 for detailed information on clearances. See Figure 33 on page 30 when installing three concentric terminations.

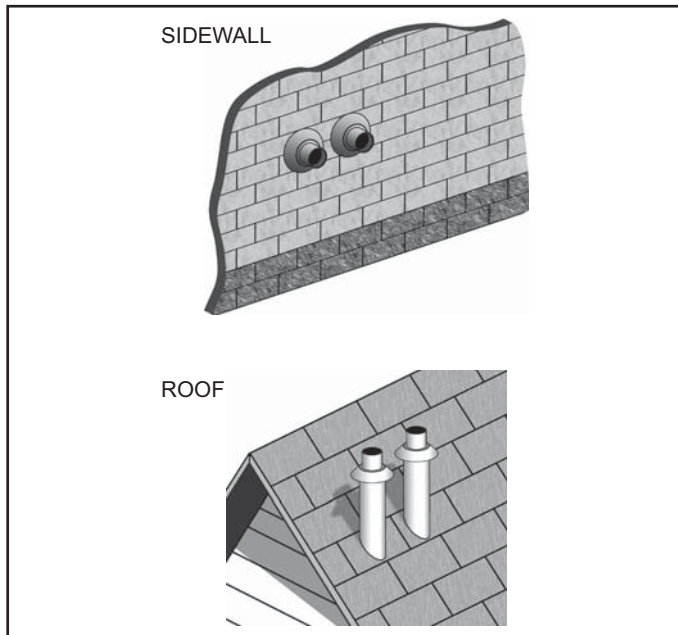

Figure 37

#### Four Concentric Terminations

Four concentric terminations may be installed in close proximity as shown in Figure 38. See Figure 34 and Figure 35 on page 30 for detailed information on clearances and additional arrangement options.

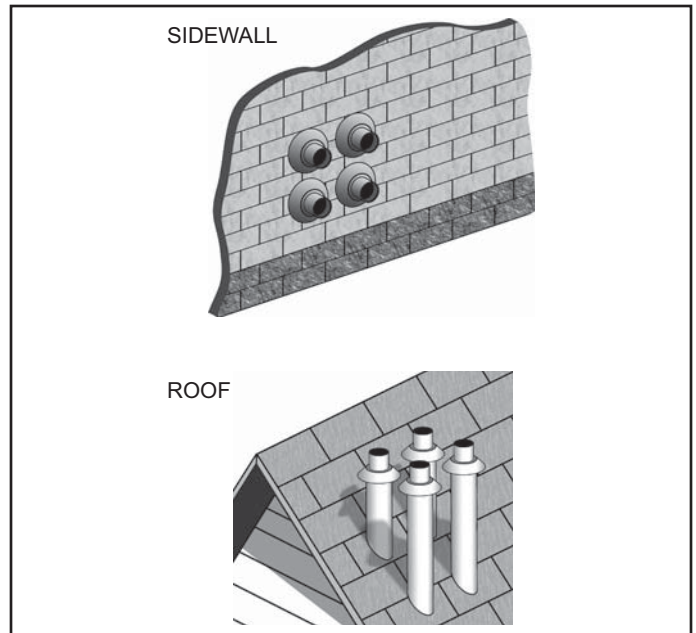

Figure 38

#### Eight Concentric Terminations

Eight concentric terminations may be installed in two stacked groups of four, in close proximity, as shown in Figure 39. See Figure 36 on page 30 for detailed information on clearances.

Lateral groups of four as shown in Figure 35 on page 30 may be a more convenient installation arrangement for multiple groups depending on available space.

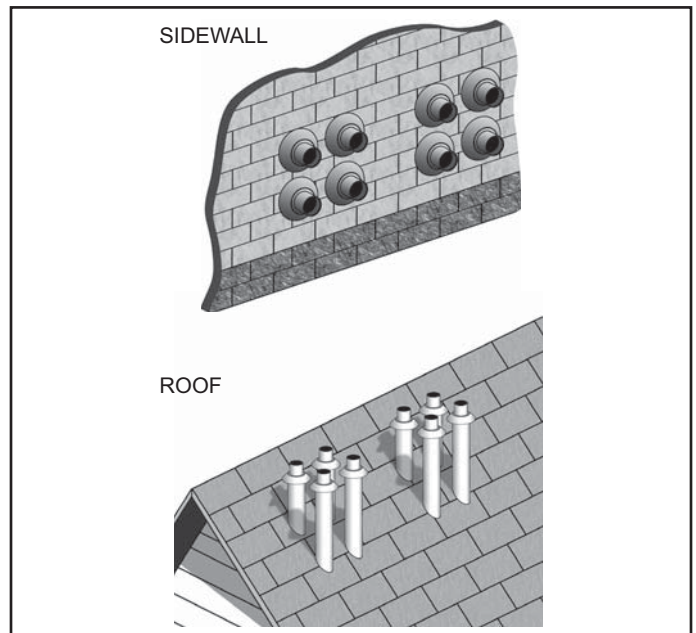
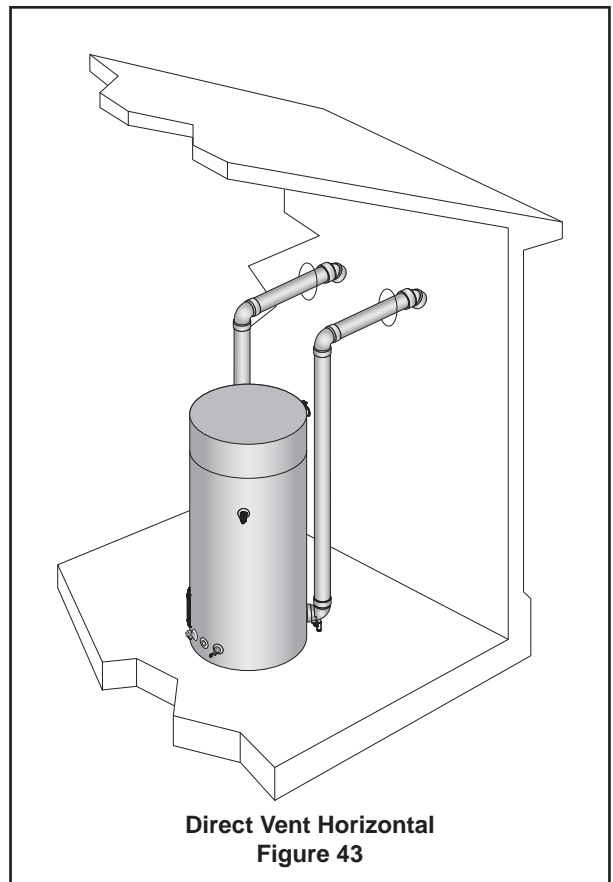
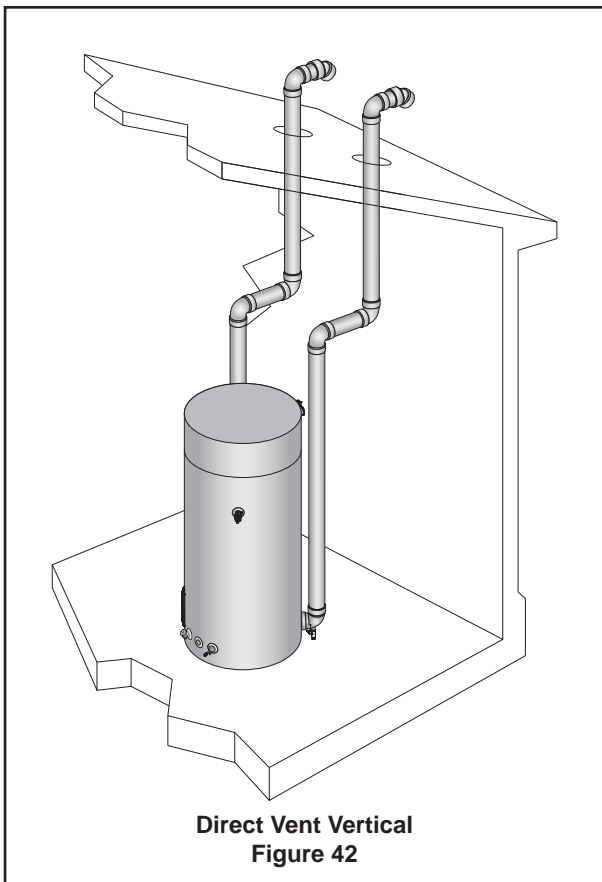
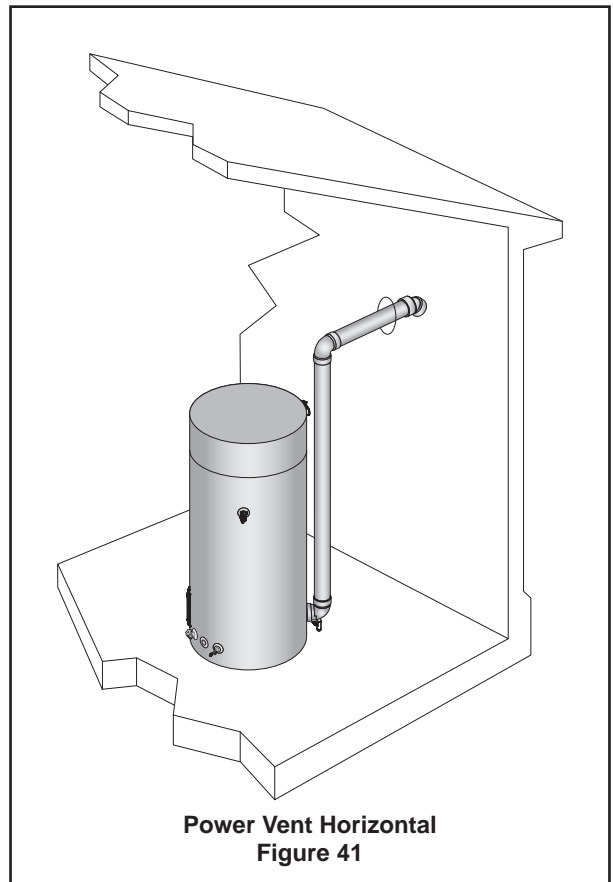
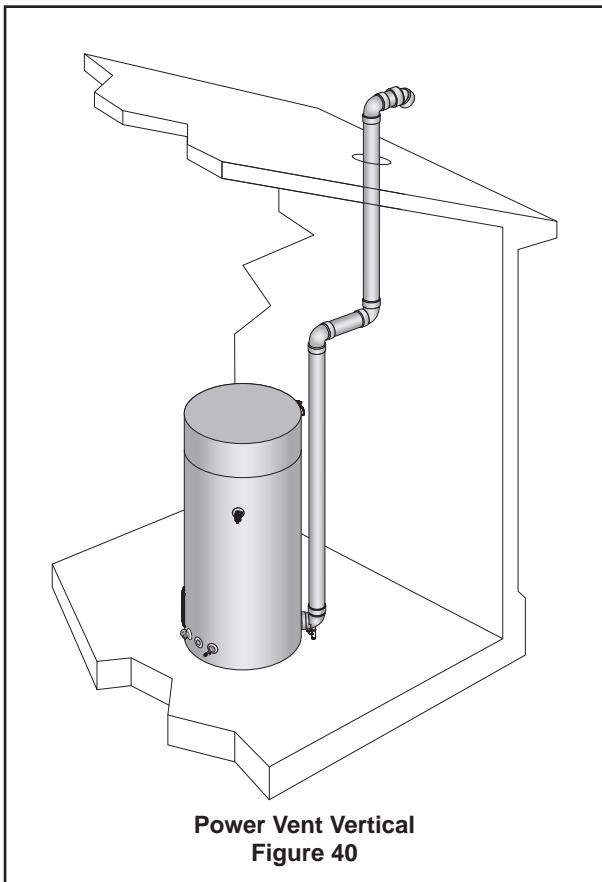
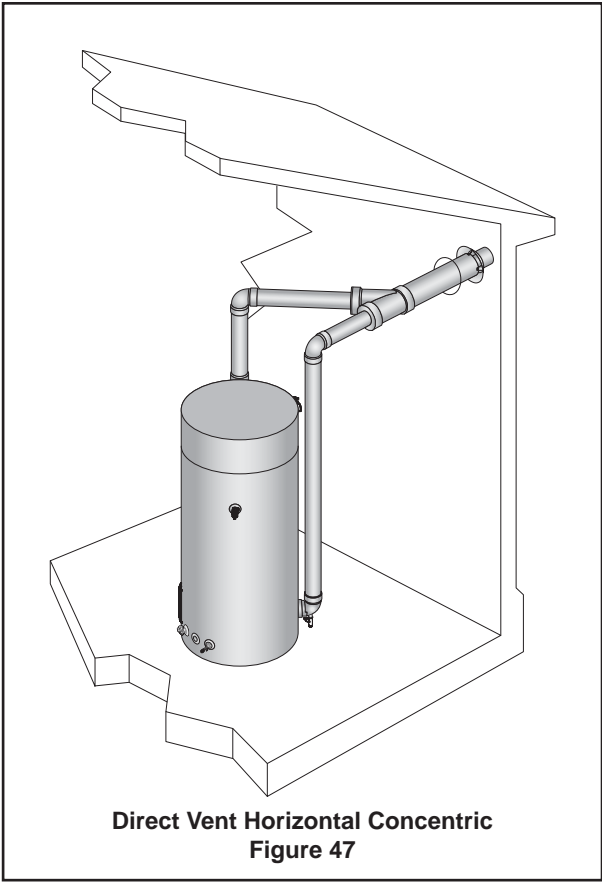
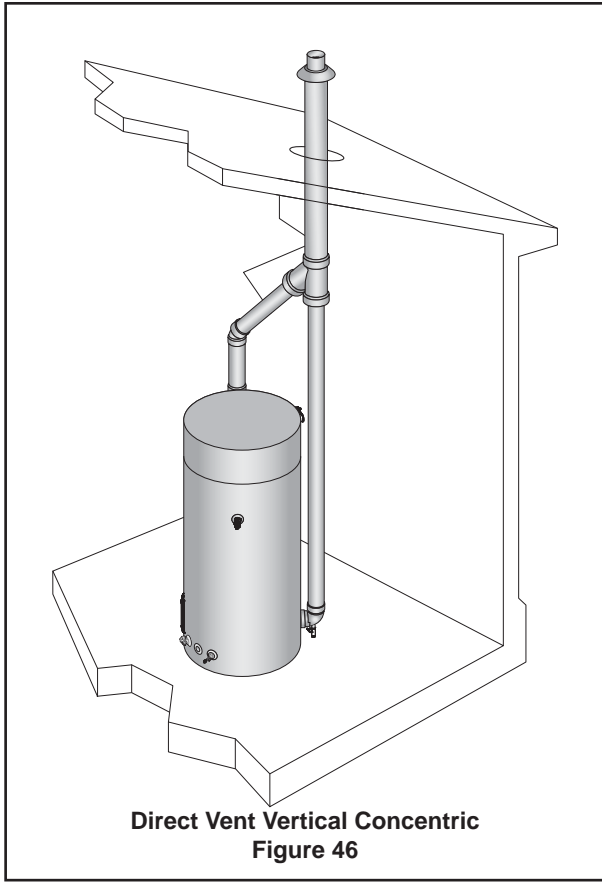
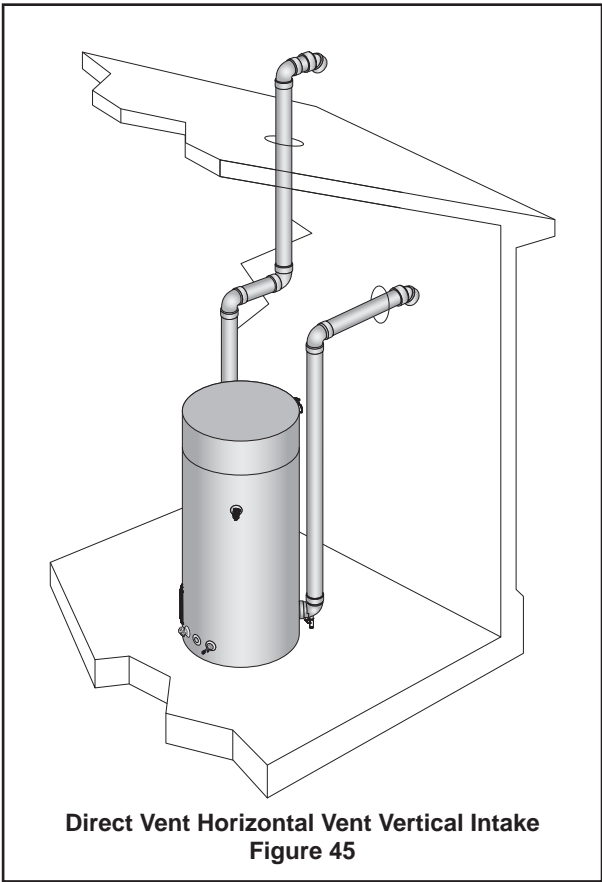
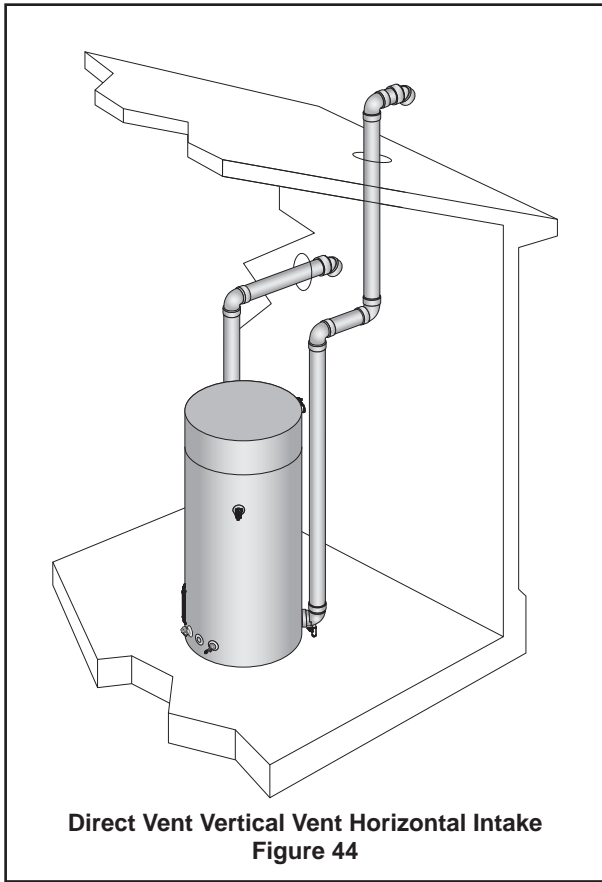

Figure 39

**VENTING ARRANGEMENTS**



**VENTING ARRANGEMENTS**





# TERMINATION CLEARANCES SIDEWALL POWER VENT

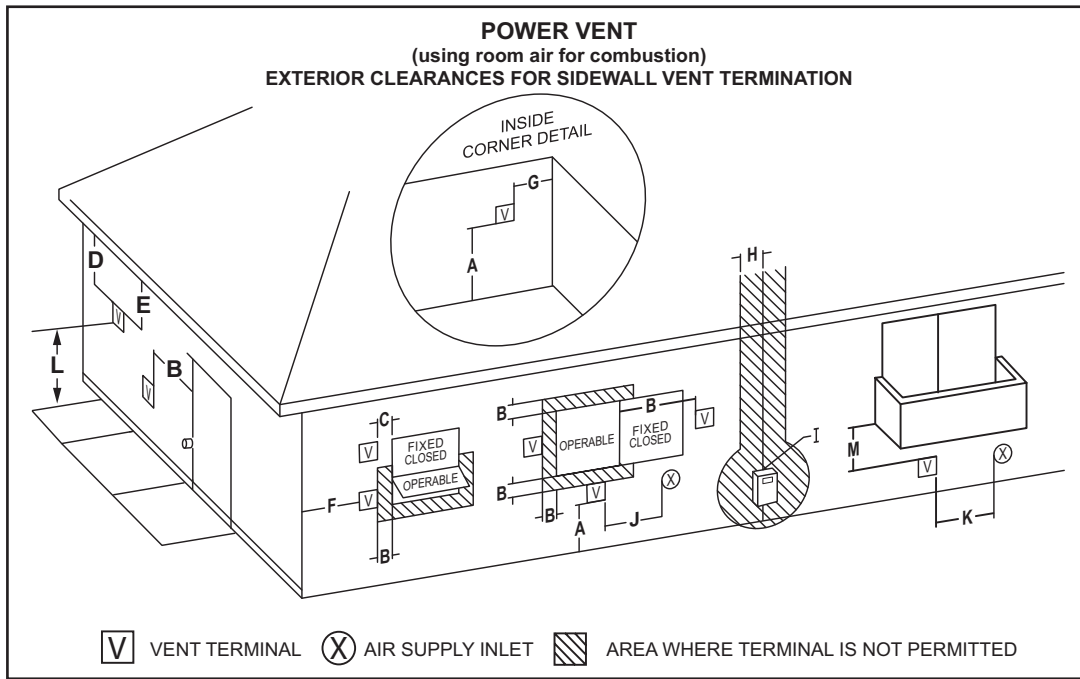

Figure 48

Vent terminal clearances for “Power Vent” installations. Power Vent configurations use room air for combustion.

	CANADIAN INSTALLATIONS <sup>1</sup>		US INSTALLATIONS <sup>2</sup>		CANADIAN INSTALLATIONS <sup>1</sup>		US INSTALLATIONS <sup>2</sup>	
<b>A</b>	Clearance above grade, veranda, porch, deck or balcony	12 inches (30 cm)	12 inches (30 cm)		<b>H</b>	Clearance to each side of center line extended above meter/regulator assembly	3 feet (91 cm) within a height 15 feet (4.5 m) above the meter/regulator assembly	3 feet (91 cm) within a height 15 feet (4.5 m) above the meter/regulator assembly*
<b>B</b>	Clearance to window or door that may be opened	6 inches (15 cm) for appliances up to 10,000 Btu/hr (3 kW), 12 inches (30 cm) for appliances between 10,000 Btu/hr (3 kW) and 100,000 Btu/hr (30 kW), 36 inches (91 cm) for appliances above 100,000 Btu/hr (30 kW)	4 feet (1.2 m) below or to side of opening; 1 foot (30 cm) above opening		<b>I</b>	Clearance to service regulator vent outlet	3 feet (91 cm)	3 feet (91 cm)*
<b>C</b>	Clearance to permanently closed window	12 inches (30 cm)*	12 inches (30 cm)*		<b>J</b>	Clearance to a non mechanical air supply inlet into building or combustion air inlet to any other appliance	6 inches (15 cm) for appliances up to 10,000 Btu/hr (3 kW), 12 inches (30 cm) for appliances between 10,000 Btu/hr (3 kW) and 100,000 Btu/hr (30kW), 36 inches (91cm) for appliances above 100,000 Btu/hr (30 kW)	4 feet (1.2 m) below or to side of opening; 1 foot (30 cm) above opening.
<b>D</b>	Vertical clearance to ventilated soffit located above the terminal within a horizontal distance of 2 feet (61 cm) from the center line of the terminal	12 inches (30 cm)*	12 inches (30 cm)*		<b>K</b>	Clearance to a mechanical air supply inlet	6 feet (1.83 m)	3 feet (91 cm) above if within 10 feet (3 m) horizontally
<b>E</b>	Clearance to unventilated soffit	12 inches (30 cm)*	12 inches (30 cm)*		<b>L</b>	Clearance above paved sidewalk or paved driveway located on public property	7 feet (2.13 m)†	7 feet (2.13 m)
<b>F</b>	Clearance to outside corner	2 feet (60 cm)*	2 feet (60 cm)*		<b>M</b>	Clearance under veranda, porch, deck, or balcony	12 inches (30 cm) ‡	12 inches (30 cm) ‡
<b>G</b>	Clearance to inside corner	18 inches (45 cm)*	18 inches (45 cm)*					

<sup>1</sup> In accordance with the current CSA B149.1, Natural Gas and Propane Installation Code.

<sup>2</sup> In accordance with the current ANSI Z223.1/NFPA 54, National Fuel Gas Code.

† A vent shall not terminate directly above a sidewalk or paved driveway that is located between two single family dwellings and serves both dwellings.

‡ Permitted only if veranda, porch, deck, or balcony is fully open on a minimum of two sides beneath the floor.

\* Clearance in accordance with local installation codes and the requirements of the gas supplier and the manufacturer’s installation instructions.

# TERMINATION CLEARANCES SIDEWALL DIRECT VENT

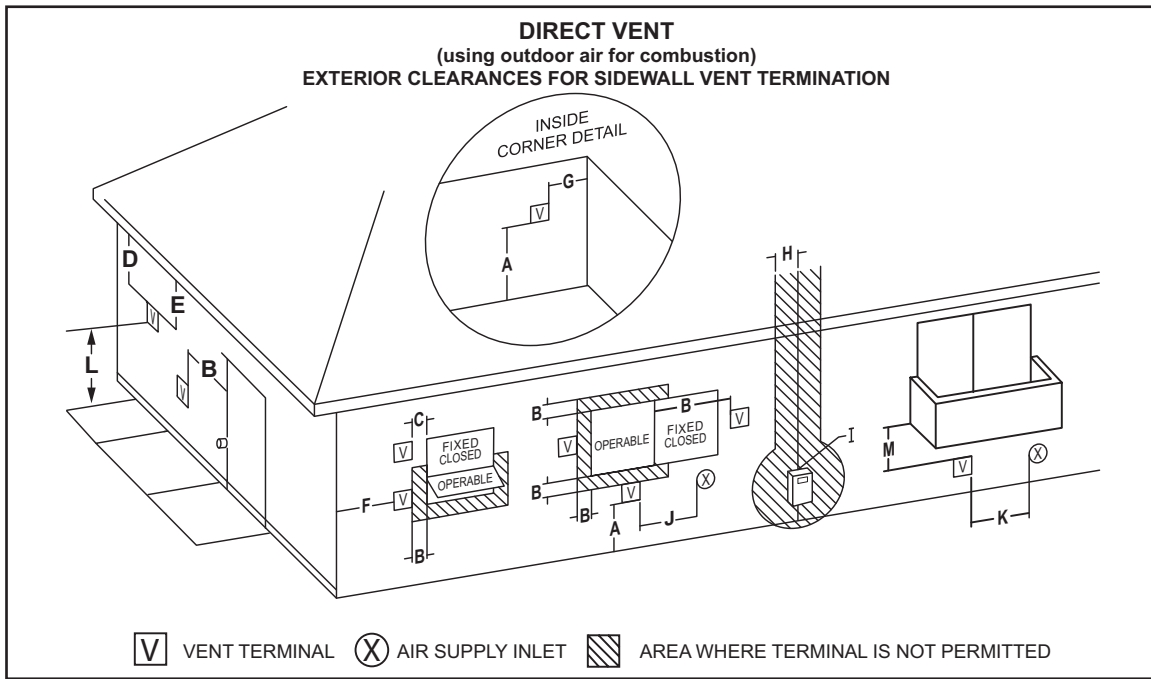

Figure 49

Vent terminal clearances for “Direct Vent” installations. Direct Vent configurations use outdoor air for combustion.

		CANADIAN INSTALLATIONS <sup>1</sup>		US INSTALLATIONS <sup>2</sup>		CANADIAN INSTALLATIONS <sup>1</sup>		US INSTALLATIONS <sup>2</sup>	
<b>A</b>	Clearance above grade, veranda, porch, deck or balcony	12 inches (30 cm)	12 inches (30 cm)	<b>H</b>	Clearance to each side of center line extended above meter/regulator assembly	3 feet (91 cm) within a height 15 feet (4.5 m) above the meter/regulator assembly	3 feet (91 cm) within a height 15 feet (4.5 m) above the meter/regulator assembly*		
<b>B</b>	Clearance to window or door that may be opened	6 inches (15 cm) for appliances up to 10,000 Btu/hr (3 kW), 12 inches (30 cm) for appliances between 10,000 Btu/hr (3 kW) and 100,000 Btu/hr (30 kW), 36 inches (91 cm) for appliances above 100,000 Btu/hr (30 kW)	6 inches (15 cm) for appliances up to 10,000 Btu/hr (3 kW), 9 inches (23 cm) for appliances between 10,000 Btu/hr (3 kW) and 50,000 Btu/hr (15 kW), 12 inches (30 cm) for appliances above 50,000 Btu/hr (15 kW)	<b>I</b>	Clearance to service regulator vent outlet	3 feet (91 cm)	3 feet (91 cm)*		
<b>C</b>	Clearance to permanently closed window	6 inches (15 cm)*	6 inches (15 cm)*	<b>J</b>	Clearance to a non mechanical air supply inlet into building or combustion air inlet to any other appliance	6 inches (15 cm) for appliances up to 10,000 Btu/hr (3 kW), 12 inches (30 cm) for appliances between 10,000 Btu/hr (3 kW) and 100,000 Btu/hr (30 kW), 36 inches (91 cm) for appliances above 100,000 Btu/hr (30 kW)	6 inches (15 cm) for appliances up to 10,000 Btu/hr (3 kW), 9 inches (23 cm) for appliances between 10,000 Btu/hr (3 kW) and 50,000 Btu/hr (15 kW), 12 inches (30 cm) for appliances above 50,000 Btu/hr (15 kW)		
<b>D</b>	Vertical clearance to ventilated soffit located above the terminal within a horizontal distance of 2 feet (61 cm) from the center line of the terminal	12 inches (30 cm)*	12 inches (30 cm)*	<b>K</b>	Clearance to a mechanical air supply inlet	6 feet (1.83 m)	3 feet (91 cm) above if within 10 feet (3 m) horizontally		
<b>E</b>	Clearance to unventilated soffit	12 inches (30 cm)*	12 inches (30 cm)*	<b>L</b>	Clearance above paved sidewalk or paved driveway located on public property	7 feet (2.13 m)†	7 feet (2.13 m)†*		
<b>F</b>	Clearance to outside corner	2 feet (60 cm)*	2 feet (60 cm)*	<b>M</b>	Clearance under veranda, porch, deck, or balcony	12 inches (30 cm) ‡	12 inches (30 cm) ‡*		
<b>G</b>	Clearance to inside corner	18 inches (45 cm)*	18 inches (45 cm)*						

1 In accordance with the current CSA B149.1, Natural Gas and Propane Installation Code.

2 In accordance with the current ANSI Z223.1/NFPA 54, National Fuel Gas Code.

† A vent shall not terminate directly above a sidewalk or paved driveway that is located between two single family dwellings and serves both dwellings.

‡ Permitted only if veranda, porch, deck, or balcony is fully open on a minimum of two sides beneath the floor.

\* Clearance in accordance with local installation codes and the requirements of the gas supplier and the manufacturer’s installation instructions.

# WATER HEATER INSTALLATION

## CONDENSATE DRAIN INSTALLATION

Installation must conform with these instructions and local building codes.

Field supplied materials required for installation include:

- Approved PVC cement and PVC primer.
- 1/2 inch PVC pipe - minimum length to equal the distance between the water heater and a suitable building drain.
- 1/2 inch PVC fittings (elbows and couplings) necessary to install a condensate drain line between the Condensate Drain Trap Assembly and a suitable building drain.
- Floor mounted standoffs to brace the drain line.

### INSTALLATION NOTES

1. The condensate drains from the water heater's covered by this instruction have PH levels between 4.3 and 5.0. Install a commercially available neutralizing kit if required by local codes. Lower PH levels are acidic. Do not connect a metal condensate drain line, such as copper pipe, to the water heater for this reason.
2. The field installed condensate drain line must not be less

than 1/2 inch PVC in size.

3. **DO NOT** remove, modify or alter the factory condensate trap.

### INSTALLATION INSTRUCTIONS

1. Ensure the water heater's on/off switch is in the "off" position.
2. Install a 1/2 inch PVC condensate drain line between the condensate drain connection on the Condensate Drain Trap and a suitable building drain, see Figure 50 and Figure 51.
3. Terminate the condensate drain piping with an elbow above the drain. Ensure that any discharge will exit the condensate drain line no more than 6 inches (15.2 cm) above a suitable building drain, or external to the building, see Figure 50.

**NOTE:** In cold climates it is recommended the condensate drain be terminated at a suitable drain inside the building.

4. Ensure the condensate drain line is not elevated above the condensate drain connection on the trap, see Figure 51.
5. Brace the condensate drain line with floor mounted standoffs every three feet.
6. Ensure the condensate drains freely during start up, see Start Up on page 50.

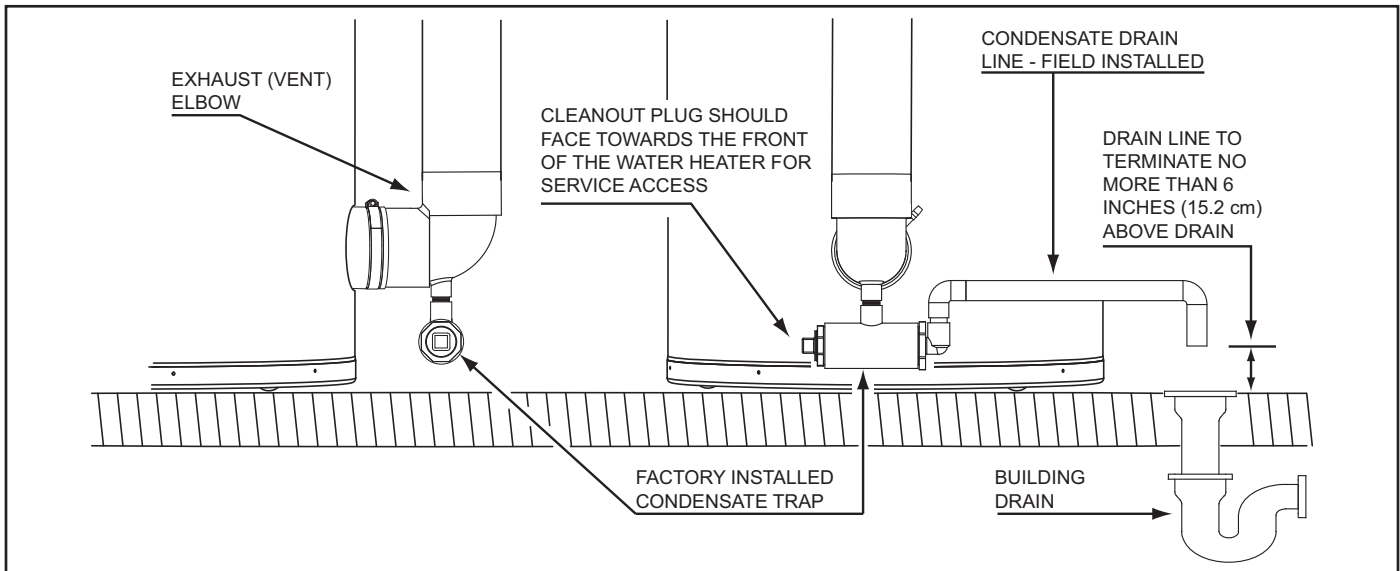

Figure 50

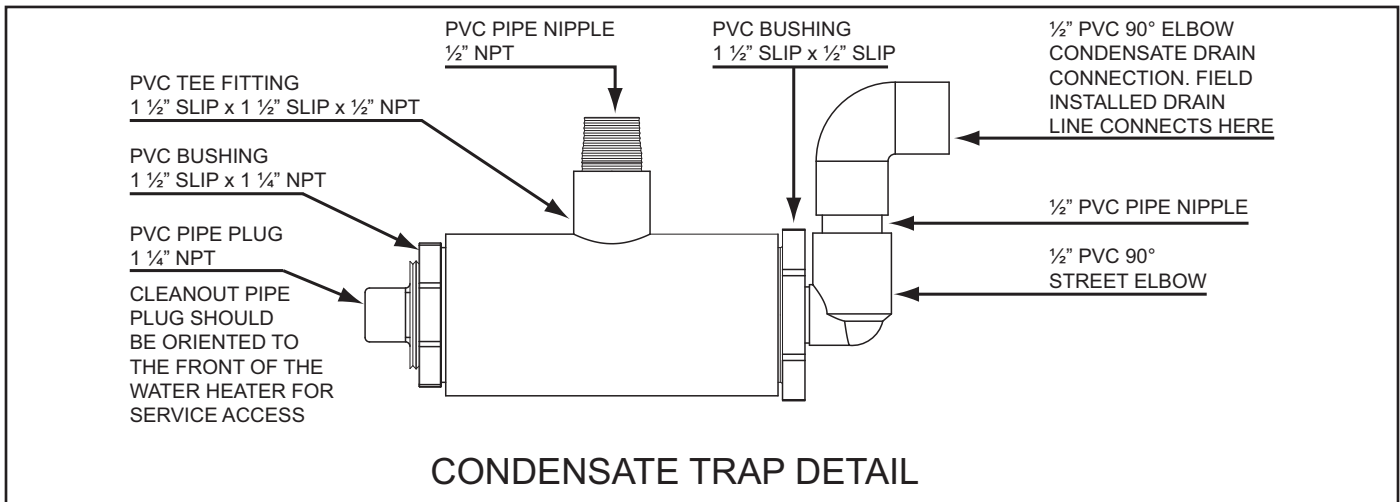



Figure 51

## SUPPLY GAS LINE INSTALLATION

Contact your local gas utility company to ensure that adequate gas service is available and to review applicable installation codes for your area.

Be sure that the gas meter has sufficient capacity to supply the rated gas input of the water heater as well as the requirements of all other gas fired equipment supplied by the meter. If the gas meter is undersized, the gas company will have to install a properly sized gas meter.



### ! WARNING

#### Fire and Explosion Hazard

- Do not use water heater with any gas other than the gas shown on the rating label.
- Excessive gas pressure to gas valve can cause serious injury or death.
- Turn off gas lines during installation.
- Contact a qualified installer or service agency for installation and service.

Make sure gas supplied is same type listed on the water heater's rating label.

The water heaters covered in this manual are not intended for operation at higher than 10.0" W. C. (2.49 kPa) for natural gas and 12.0" W. C. (2.99 kPa) for propane gas supply pressure, see Table 4 on page 13. The water heaters covered in this manual require supply gas regulators to maintain required supply gas pressure. Exposure to higher gas supply pressure may cause damage to the gas controls which could result in fire or explosion. If overpressure has occurred such as through improper testing of gas lines or malfunction of the supply system the water heater's gas valve must be checked for safe operation by a Qualified Service Agency.

Ensure supply regulator vent lines and the safety vent valves are protected against blockage. These are components of the gas supply system, not the water heater. Vent blockage may occur during ice storms.

It is important to guard against gas valve fouling from contaminants in the gas ways. Such fouling may cause improper operation, fire or explosion. If copper supply lines are used they must be internally tinned and certified for gas service.

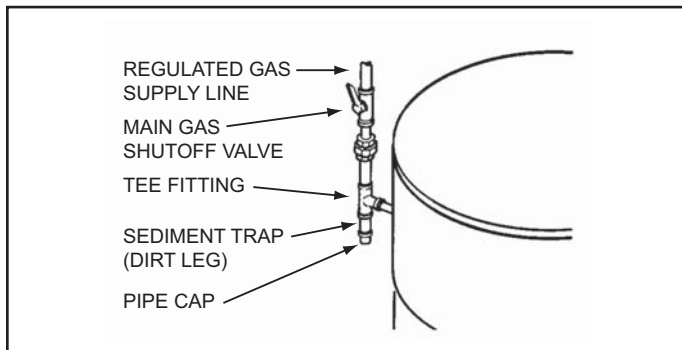

**Figure 52**

Ensure all gas pipe is clean on the inside before installation. To trap any dirt or foreign material in the gas supply line a sediment trap (dirt leg) must be installed as shown in Figure 52. The sediment trap must be readily accessible and not subject to freezing conditions. Install in accordance with the recommendations of the local gas utility company.

## GAS LINE SIZING

**DO NOT** use flexible gas piping.

Minimum required supply gas line sizes are shown in Table 5 on page 13. Depending on the developed equivalent length and/or the number of appliances connected to a common main, the size of supply gas lines may have to be increased.

Size the supply/main gas line(s) in accordance with Table 8 or Table 9. The values given in Table 8 and Table 9 are for straight lengths of iron pipe at 0.5" W. C. (125 Pa) pressure drop, which is considered normal for low pressure systems. Note that fittings such as elbows and tees will add to the pipe pressure drop.

### SUPPLY GAS LINE SIZING U. S. UNITS

**TABLE 8**

LENGTH IN FEET	NORMAL IRON PIPE SIZES (INCHES)					
	INPUT IN THOUSANDS BTU/HR					
	1 1/4"	1 1/2"	2"	2 1/2"	3"	4"
10	1400	2100	3960	6300	11000	23000
20	950	1460	2750	4360	7700	15800
30	770	1180	2200	3520	6250	12800
40	660	990	1900	3000	5300	10900
50	580	900	1680	2650	4750	9700
60	530	810	1520	2400	4300	8800
70	490	750	1400	2250	3900	8100
80	460	690	1300	2050	3700	7500
90	430	650	1220	1950	3450	7200
100	400	620	1150	1850	3250	6700
125	360	550	1020	1650	2950	6000
150	325	500	950	1500	2650	5500
175	300	460	850	1370	2450	5000
200	N/A	430	800	1280	2280	4600

### SUPPLY GAS LINE SIZING METRIC UNITS

**TABLE 9**

LENGTH IN METERS	NORMAL IRON PIPE SIZES (INCHES)					
	INPUT IN kW					
	1 1/4"	1 1/2"	2"	2 1/2"	3"	4"
3.0	410	615	1160	1845	3221	6735
6.1	278	428	805	1277	2255	4626
9.1	225	346	644	1031	1830	3748
12.2	193	290	556	878	1552	3192
15.2	170	264	492	776	1391	2840
18.3	155	237	445	703	1259	2577
21.3	143	220	410	659	1142	2372
24.4	135	202	381	600	1083	2196
27.4	126	190	357	571	1010	2108
30.5	117	182	337	542	952	1962
38.1	105	161	299	483	864	1757
45.7	95	146	278	439	776	1610
53.3	88	135	249	401	717	1464
61.0	N/A	126	234	375	688	1347

## GAS LINE CONNECTION

1. The water heaters covered by this manual are shipped from the factory with a 1 1/4" supply gas connection, see Table 1 on page 10. Short pipe nipples and reducer couplings are factory installed to increase the size of the water heater's 24 VAC Gas Valve inlet, see Figure 53. Connect the supply gas line to the water heater's 24 VAC Gas Valve in accordance with all applicable local and national code requirements. **DO NOT** use flexible gas piping.
2. SUF 130 500 natural gas models (Series 100) require a 1 1/2" minimum supply gas line. All other water heaters covered by this manual require a 1 1/4" minimum supply gas line. See Table 5 on page 13.

Install a field supplied 1 1/2" x 1 1/4" reducer coupling and 1 1/4" pipe nipple to accommodate the minimum required 1 1/2" supply gas line as shown in Figure 53 on SUF 130 500 natural gas models (Series 100).

See the rating label on the water heater to verify fuel type and Series number.

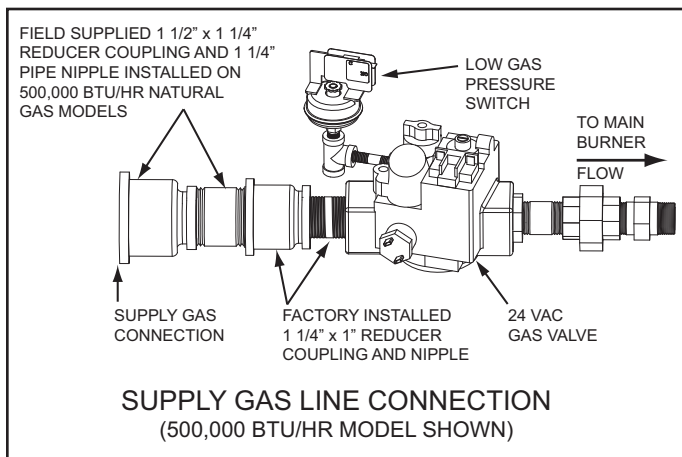
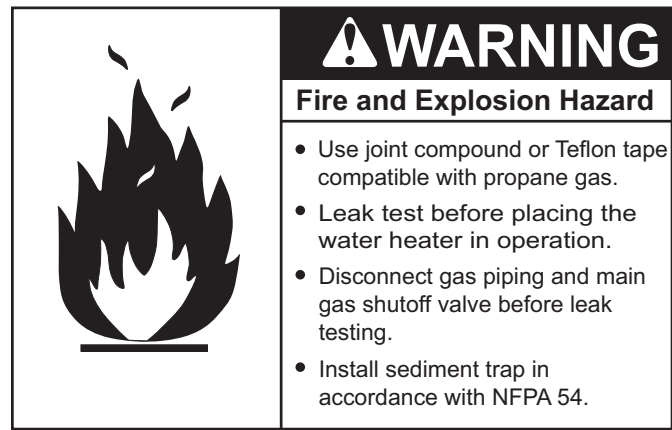

**Figure 53**

3. Apply thread sealing compounds (pipe dope/ Teflon tape) sparingly and only to the male threads of the pipe joints. Do not apply sealing compound to the first two threads. Use pipe dope or Teflon tape marked as being resistant to the action of liquid petroleum (LP/propane) gases.
4. Use only a smooth jaw adjustable wrench (such as a monkey wrench) as a back up on the body of the 24 VAC Gas Valve when tightening the first pipe nipple into the body of the valve. **DO NOT** use a standard pipe wrench (Stillson wrench) with metal tooth jaws as this may permanently damage the valve.
5. Use a standard pipe wrench (Stillson wrench) as a back up on the first pipe nipple installed above when connecting other fittings and pipe in the supply gas line to prevent the 24 VAC Gas Valve on the water heater from twisting during installation.
6. To prevent damage, care must be taken not to apply too much torque when connecting the supply gas line to the water heater.
7. Install a sediment trap (dirt leg) as shown in Figure 52 on page 37.
8. Install a Main Gas Shutoff valve in the supply gas line as shown in Figure 52 on page 37.

**NOTE:** Should overheating occur or the gas supply fail to shut off, turn off the Main Gas Shutoff valve to the water heater.

## GAS LINE LEAK TESTING



Any time work is done on the gas supply system perform a leak test to avoid the possibility of fire or explosion.

1. For test pressures exceeding 1/2 psi (3.45 kPa) disconnect the water heater and its Main Gas Shutoff Valve from the gas supply piping system during testing, see Figure 52 on page 37. The gas supply line must be capped when disconnected from the water heater.
2. For test pressures of 1/2 psi (3.45 kPa) or less, the appliance need not be disconnected, but must be isolated from the supply gas line by closing the Main Gas Shutoff Valve during testing.
3. Paint all supply gas line joints and connections upstream of the water heater with a rich soap and water solution to test for leaks. Bubbles indicate a gas leak. Do not use matches, candles, flame or other sources of ignition for this purpose.
4. Repair any leaks before placing the water heater in operation.

## SUPPLY GAS REGULATOR INSTALLATION

The water heaters covered in this manual must have a supply gas regulator installed in the supply gas line connected to the water heater. See the Installation Requirements on page 13.

1. A supply gas regulator shall be installed for each water heater on multiple water heater installations.
2. Supply gas regulators must be rated at or above the input Btu/hr rating of the water heater they supply.
3. Supply gas regulators shall have inlet and outlet connections not less than the minimum supply gas line size for the water heater they supply. See Table 5 on page 13.  
The Maxitrol 325-7L supply gas regulator or equivalent is recommended.
4. Supply gas regulator(s) shall be installed no closer than 3 feet (1 meter) and no farther than 10 feet (3 meters) from the supply gas connection on the water heater.



## ELECTRICAL WIRING

All electrical work must be installed in accordance with the National Electrical Code, ANSI/NFPA 70 or the Canadian Electrical Code, CSA C22.1 and local requirements.

When installed, the water heater must be electrically grounded in accordance with local codes or, in the absence of local codes, with the National Electrical Code, ANSI/NFPA 70 or the Canadian Electrical Code, CSA C22.1.

If any of the original wire as supplied with the water heater must be replaced, it must be replaced with 105°C rated wiring or its equivalent, except in the burner housing. In this case use 200°C rated wire must be used.

### POWER SUPPLY CONNECTIONS

Read the requirements for the Power Supply on page 13 before connecting power.

#### Correct Polarity:

The water heater's control system is polarity sensitive and will lock out and disable heating operation if the polarity of the power supply is reversed. The control system will display the "AC Reversed" Fault message on the LCD. The 120 VAC hot wire from the power supply must connect to the black wire in the junction box and the 120 VAC neutral wire must connect to the white wire in the junction box for correct polarity.

Power supply connections must be made as follows:

1. Ensure the power supply is turned off at the breaker or disconnect switch.
2. Remove the junction box cover. See Figure 3 on page 8 for junction box location.
3. Connect the 120 VAC hot wire from the power supply to the black wire in the junction box on top of the water heater with a properly sized wire nut. Wrap electrical tape around the wire nut and wire end. See wiring diagrams Figure 62 on page 64 and Figure 63 on page 65.
4. Connect the 120 VAC neutral wire from the power supply to the white wire in the junction box. Wrap electrical tape around the wire nut and wire end. See wiring diagrams Figure 62 on page 64 and Figure 63 on page 65.
5. Connect the ground wire from the power supply to the grounding lug inside the junction box. See wiring diagrams Figure 62 on page 64 and Figure 63 on page 65.
6. Replace the junction box cover when connections are complete.

**NOTE:** Do not apply power to the water heater before installation is complete and the water heater is filled with water.

### ENABLE/DISABLE CIRCUIT

The water heaters covered in this manual are equipped with an enable/disable circuit for use with field supplied external supervisory controls such as time clocks or building Building Management Systems. The enable/disable circuit may be used to disable heating operation during periods when the building is unoccupied or there is no demand for hot water.

To use the enable/disable circuit it must first be activated by configuring the S1 dipswitch on the water heater's CCB (central control board), see Figure 61 on page 63. Field supplied wiring is then installed between the water heater's CCB and a set of "dry contacts" (no voltage or load) on the field supplied external control.

**NOTE:** The water heater's enable/disable circuit is a switching circuit only: Do not apply external voltage or connect any load (IE: relay coil) to this circuit. This will damage the CCB circuit

board and is not covered under the limited warranty.

### Connecting An External Supervisory Control

The enable/disable circuit is accessed from the CCB's J6 plug inside the CCB enclosure, see Figure 3 on page 8 to locate the CCB enclosure. From the factory there is a short (black) jumper wire installed between pins 8 and 11 of the J6 plug, see Figure 61 on page 63 to locate the J6 plug.

Install field wiring to the enable/disable circuit:

1. Turn off power at the water heater's on/off switch and the breaker that supplies power to the appliance.
2. Locate the CCB enclosure.
3. Remove the screws from the CCB enclosure cover and carefully open the CCB enclosure. Note how strain relief for the wiring is provided between the cover and enclosure along one edge.
4. Activate the enable/disable circuit; locate the S1 dipswitch on the CCB, see Figure 61 on page 63.
  - Toggle S1 dipswitch #2 to the open position.
  - Toggle S1 dipswitch #3 to the open position.
5. Locate the black jumper wire between pin 8 and 11 on the CCB J6 plug, see Figure 61 on page 63 and Figure 62 on page 64.
6. Cut the black jumper wire in the middle.
7. Strip approximately 1/2 inch of insulation from the two ends of the black jumper wire.
8. Using wire nuts connect two field supplied control wires to the two ends of the black jumper wire. Wrap electrical tape around the wire nut connections.
9. Thread the control wires out of the CCB enclosure with the other wiring and carefully replace the CCB enclosure cover. Ensure all wiring is routed through the indented area provided for strain relief. Ensure no wiring is being pinched.
10. Reinstall the CCB enclosure cover screws and tighten.
11. Route the control wires inside the junction box on the top of the water heater, see Figure 3 on page 8 to locate the junction box. Use an available knock-out to route the wires inside the junction box.
12. Install field supplied control wiring and conduit as required by national and local codes between the water heater's junction box and the external supervisory control. Connect the wiring from the external control to the control wires inside the junction box using wire nuts and electrical tape.
13. Connect the control wiring to a set of dry contacts on the external control. Follow the control manufacturers instructions for making connections.
14. Restore power to the water heater.

**NOTE:** Whenever the external control opens the set of dry contacts used, heating operation will be disabled. Whenever the external control closes the set of dry contacts used, heating operation will be enabled. A diagonal line and circle appears over the thermometer icon on the control system's display when heating operation is disabled. See the Status Icons descriptions in Table 11 on page 43.

**NOTE:** Ensure the water heater is protected from freezing temperatures when heating operation is disabled. Damage to the water heater caused by freezing temperatures is not covered under the limited warranty.

## WATER LINE CONNECTIONS

The water piping installation must conform to these instructions and to all local and national code authority having jurisdiction. Good practice requires that all heavy piping be supported.

Read and observe all requirements in the following sections before installation of the water piping begins:

1. Mixing Valves on page 14.
2. Dishwashing Machines on page 14.
3. Temperature-Pressure Relief Valve on page 15.
4. Closed Systems and Thermal Expansion on page 14.
5. For multiple water heater installations see Water Piping Diagrams beginning on page 67.

### WATER PIPING DIAGRAMS

This manual provides detailed water piping diagrams for typical methods of application for the water heaters, see Water Piping Diagrams beginning 67.

The water heater may be installed by itself, or with a separate storage tank. When used with a separate storage tank, the circulation may be either by gravity or by means of circulating pump. When a circulating pump is used, it is important to note that the flow rate should be slow so that there will be a minimum of turbulence inside the water heater storage tank.

Adjust flow by throttling a full port ball valve installed in the circulating line on the outlet side of the pump. Never throttle flow on the suction side of a pump. See the Water Piping Diagrams beginning on page 67.

**NOTE:** In addition to the factory installed Temperature-Pressure Relief Valve (T&P valve) on the water heater, each remote storage tank that may be installed and piped to a water heating appliance must also have its own properly sized, rated and approved Temperature-Pressure Relief Valve installed.

Call the toll free technical support phone number listed on the back cover of this manual for further assistance in sizing a T&P valve for remote storage tanks.

### THERMOMETERS (NOT SUPPLIED)

Thermometers are installed in the water piping system as a means of detecting the temperature of the hot water supply at critical points in the system. Field supplied thermometers should be obtained and installed. See Water Piping Diagrams on page 67.

### WATER (POTABLE) HEATING AND SPACE HEATING

1. All water piping components connected to the water heater that are for space heating applications shall be suitable for use with potable water.
2. Toxic chemicals, such as those used for boiler treatment, must NEVER be introduced into this system.
3. The water heaters covered in this manual may never be connected to any existing heating system or component(s) previously used with non-potable water heating appliance.
4. When the system requires water for space heating that exceed safe temperatures at domestic water fixtures a mixing valve must be installed, see Mixing Valves on page 14.

## T&P VALVE DISCHARGE PIPE

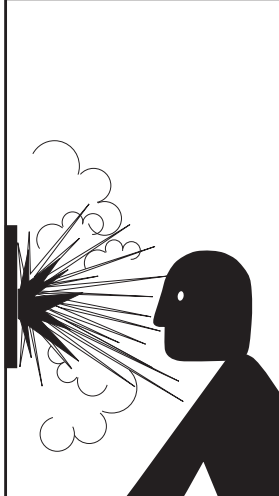
	<b>WARNING</b>
	<b>Explosion Hazard</b>
	<ul style="list-style-type: none"><li>• Temperature-Pressure Relief Valve must comply with ANSI Z21.22- CSA 4.4 and ASME code.</li><li>• Properly sized temperature-pressure relief valve must be installed in opening provided.</li><li>• Can result in overheating and excessive tank pressure.</li><li>• Can cause serious injury or death.</li></ul>

This water heater is provided with a properly rated/sized and certified combination temperature - pressure (T&P) relief valve by the manufacturer. See Temperature-Pressure Relief Valve on page 15 for information on replacement and other requirements.

<b>CAUTION</b>
<b>Water Damage Hazard</b>
<ul style="list-style-type: none"><li>• Temperature-Pressure Relief Valve discharge pipe must terminate at adequate drain.</li></ul>

Install a discharge pipe between the T&P valve discharge opening and a suitable floor drain. Do not connect discharge piping directly to the drain unless a 6" (15.2 cm) air gap is provided. To prevent bodily injury, hazard to life, or property damage, the relief valve must be allowed to discharge water in adequate quantities should circumstances demand. If the discharge pipe is not connected to a drain or other suitable means, the water flow may cause property damage.

### T&P Valve Discharge Pipe Requirements:

- Shall not be smaller in size than the outlet pipe size of the valve, or have any reducing couplings or other restrictions.
- Shall not be plugged or blocked.
- Shall not be exposed to freezing temperatures.
- Shall be of material listed for hot water distribution.
- Shall be installed so as to allow complete drainage of both the Temperature-Pressure Relief Valve and the discharge pipe.
- Must terminate a maximum of six inches above a floor drain or external to the building. In cold climates, it is recommended that the discharge pipe be terminated at an adequate drain inside the building.
- Shall not have any valve or other obstruction between the relief valve and the drain.

# TEMPERATURE REGULATION

## HIGH TEMPERATURE LIMIT CONTROL (ECO)

This water heater is equipped with an ECO (energy cut off) non adjustable high temperature limit switch. The ECO is a normally closed switch that opens (activates) on a rise in temperature.

The ECO is located inside the Upper Temperature Probe (two red wires), see Figure 3 on page 8 for location. The ECO switch contacts will open when the water temperature reaches approximately 202°F (94°C) and close at approximately 140°F (49°C).

If the ECO activates (contacts open) due to abnormally high water temperatures in the storage tank the control system will immediately de-energize the 24 VAC Gas Valve and end the current heating cycle. The control system will "lock out" disabling further heating operation. The control system will display the "Energy Cut Out (ECO)" Fault message on the LCD screen. It is important that a Qualified Service Agent be contacted to determine the reason for the ECO activation before resetting the ECO. Once the reason has been determined and corrected the ECO can be reset as follows:

Should the ECO activate, the water temperature must drop below 140°F (49°C) before the control system can be reset. Once the water temperature has cooled below this point the power supply to the water heater must be turned off and on again to reset the control system.

## THERMOSTAT CONTROL

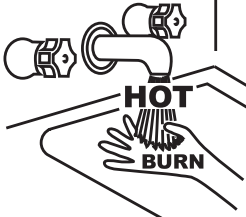

**⚠ DANGER** Water temperature over 125°F (52°C) can cause severe burns instantly resulting in severe injury or death.

Children, the elderly and the physically or mentally disabled are at highest risk for scald injury.

Feel water before bathing or showering.

Temperature limiting devices such as mixing valves must be installed when required by codes and to ensure safe temperatures at fixtures.

Hot water temperatures required for automatic dishwasher and laundry use can cause scald burns resulting in serious personal injury and/or death. Table 10 shows the approximate time-to-burn relationship for normal adult skin.

The temperature at which injury occurs varies with the person's age and duration of exposure. The slower response time of children, the elderly or disabled persons increases the hazards to them. If anyone using hot water provided by the water heater being installed fits into one of these groups or if there is a local code or state law requiring a certain water temperature at the point of use, then special precautions must be taken.

In addition to using the lowest possible temperature setting that satisfies the demand of the application a mixing valve can be installed at the water heater (see Figure 8 on page 14) or at the hot water taps to further reduce system water temperature.

Never allow small children to use a hot water tap or draw their own bath water. Never leave a child or disabled person unattended in a bathtub or shower.

The water heater should be located in an area where the general public does not have access to set temperatures.

Setting the Operating Set Point at 120°F (49°C) will reduce the risk of scalds. Some States require settings at specific lower temperatures.

**TABLE 10**

Water Temperature	Time to Produce 2nd & 3rd Degree Burns on Adult Skin
180°F (82°C)	Nearly instantaneous
170°F (77°C)	Nearly instantaneous
160°F (71°C)	About 1/2 second
150°F (66°C)	About 1-1/2 seconds
140°F (60°C)	Less than 5 seconds
130°F (54°C)	About 30 seconds
120°F (49°C)	More than 5 minutes

The water heaters covered in this manual are equipped with an electronic control system to regulate the water temperature inside the storage tank. The control system senses temperature from two factory installed temperature probes, one installed in the top of the storage tank and one installed near the bottom, See Figure 3 on page 8 and Figure 4 on page 9 for location.

The "Operating Set Point" is adjusted to regulate water temperature inside the storage tank. This is an adjustable user setting in the control system's "Temperatures Menu." This and all control system menus are accessed through the UIM (user interface module) located on the front of the water heater, see Figure 54.

The Operating Set Point is adjustable from 90°F (42°C) to 180°F (82°C). The factory setting is 120°F (49°C). See Operating Set Point And Differential Adjustment on page 45 for instructions on how to adjust the Operating Set Point and other user settings.

Set the Operating Set Point at the lowest setting which produces an acceptable hot water supply. This will always provide the most energy efficient operation.

## HIGH TEMPERATURE APPLICATIONS

Higher operating temperatures cause more wear on all water heaters and will decrease the life span of the appliance. Consider installing a small booster water heater for high temperature applications, such as commercial dishwashers, to raise the outlet temperature from the larger primary water heater to the desired point of use temperature.

Contact your local distributor or call the technical support phone number listed on the back cover of this manual for further technical assistance.

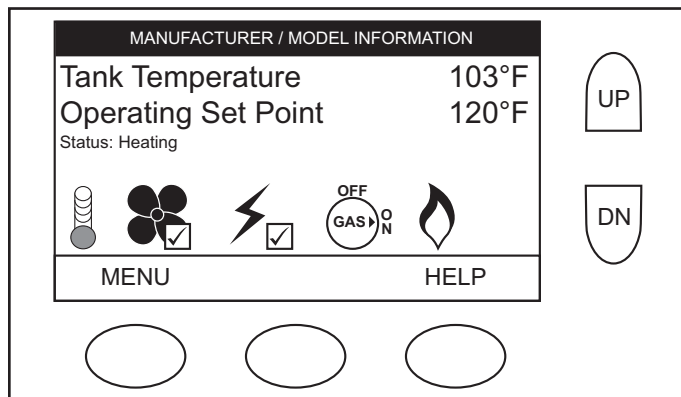

**Figure 54**

# CONTROL SYSTEM OPERATION

## OVERVIEW

The water heaters covered in this manual are equipped with an electronic control system that regulates water temperature inside the storage tank. Heating cycles and ignition are managed by the control system. The ECO (energy cut out), flame sensor, pressure switches and temperature probes are monitored by the control system. The Combustion Blower, igniter, 24 VAC Gas Valve and anode rods are all powered by the control system.

The main components of the control system are a UIM (user interface module) and a CCB (central control board). The UIM is located on the top front side of the water heater. The CCB is mounted on top of the water heater inside a protective enclosure. See Features And Components on page 7 for location of these and all water heater components.

## CONTROL SYSTEM NAVIGATION

All operational information and user settings are displayed and accessed from the UIM. The UIM houses the control system's LCD (liquid crystal display) and five snap acting (momentary) user input buttons; an up, down and three (3) multi functional operational buttons below the LCD, see Figure 55.

### User Input Buttons

- The up and down buttons are used to navigate menus and adjust user settings.
- The operational buttons are used to enter/exit menus, select menu items, activate adjustment modes and confirm or cancel new user settings. The operational buttons are multifunctional, their current function is defined by the text that appears directly above each button on the LCD screen.

## THE DESKTOP SCREEN

During normal operation the control system will display the "Desktop" screen on the LCD which is the default screen. The control system will return to the Desktop screen when there are no active Fault or Alert conditions or when there has been no user input for several minutes.

- Manufacturer and water heater model information is displayed in Title Bar at the top of the Desktop screen. Menu titles are displayed in the Title Bar when navigating the control system menus.
- The first temperature shown on the Desktop screen, Tank Temperature, is the temperature of the water inside the water heater's storage tank.
- The second temperature shown on the Desktop screen is the Operating Set Point. The Operating Set Point is the temperature at which the control system will maintain the water inside the storage tank.
- Beneath the Operating Set Point is the "Status" line. The Status line shows the current operational state of the control system in real time, see Table 12 on page 44 for a description of the various operational states.
- The Desktop screen also displays animated "Status Icons" to convey operational information, see Table 11 on page 43 for descriptions of the Status Icons.

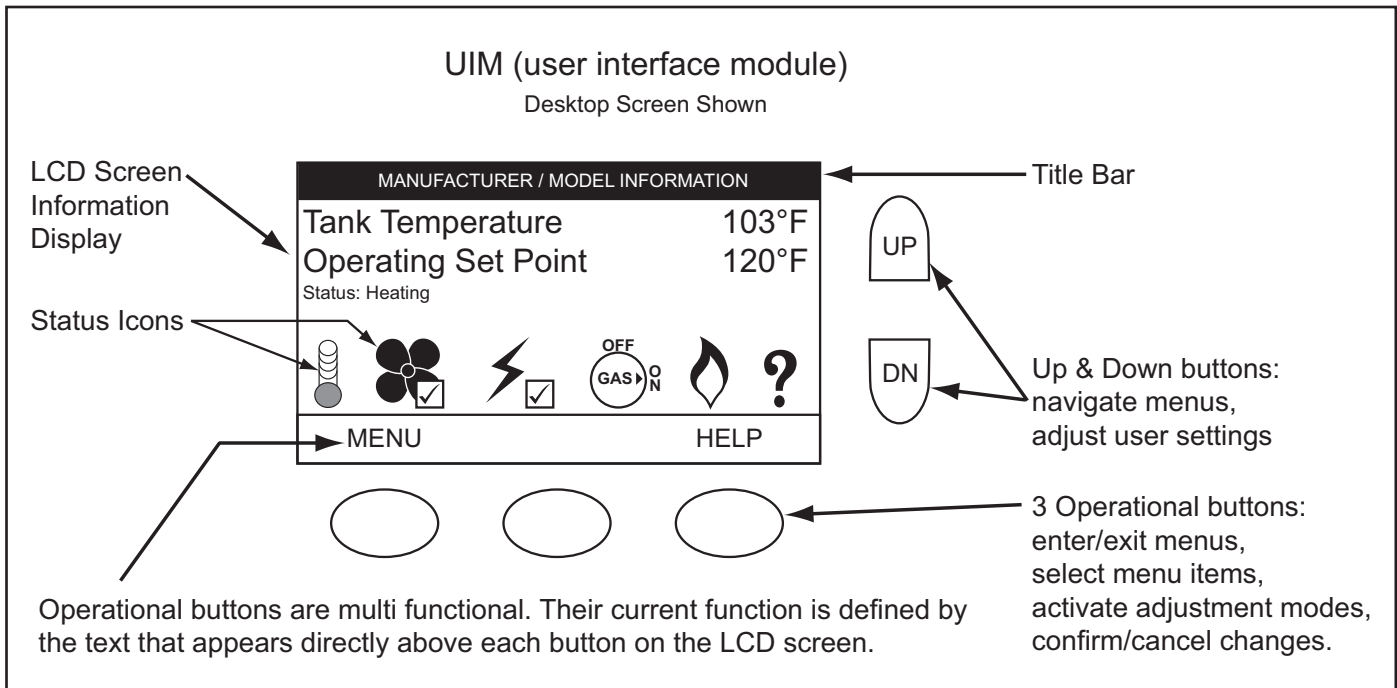













Figure 55



## STATUS ICONS

The Status Icons are displayed on the Desktop screen and convey operational and diagnostic information. The icons are described in the table below. See Figure 55 on page 42 and the Sequence Of Operation on page 54.

**TABLE 11**

Icon	Description
	Water temperature in the tank has fallen. Shaded area of the animated thermometer icon will rise and fall in response to water temperature in the storage tank as sensed from the Upper and Lower Temperature Probes. See Figure 3 on page 8 and Figure 4 on page 9 for location of Temperature Probes.
	Water temperature in the tank has reached the Operating Set Point. The control system enters the Standby mode.
	The control is unable to initiate a heating cycle. This will happen whenever a Fault condition is detected by the control system or when the Enable/Disable circuit is an open circuit. For more information see Enable/Disable Circuit on page 39.
	The Combustion Blower is being energized.
	The Blower Prover pressure switch contacts have closed. The check mark icon is visual confirmation of contact closure. See Figure 3 on page 8 for Blower Prover Switch location.
	The Hot Surface Igniter is being energized. See Figure 2 on page 7 for Hot Surface Igniter location.
	The igniter has been energized and the control system has sensed the required minimum igniter current. The check mark icon is visual confirmation of minimum igniter current. See the Sequence Of Operation on page 54 for minimum current (AC amps) information.
	The 24 VAC Gas Valve is being energized.
	The control system has sensed flame at the Main Burner from the flame sensor. See the Sequence Of Operation Flow Chart on page 55 and Figure 2 on page 7.
	The control system has declared a Fault condition and must be inspected/serviced by a Qualified Service Agent. Fault message details can be viewed in the Current Fault menu. Heating operation is disabled (lock out) until the condition that caused the Fault is corrected. Power to the water heater must be cycled off and on to reset the control system. <b>NOTE:</b> Cycling power will not reset the control system if the condition that caused the Fault has not been corrected.
	The control system has declared an Alert condition and must be inspected/serviced by a Qualified Service Agent. The water heater will continue to operate during an Alert condition.



## OPERATING STATES

The current operational state of the water heater is displayed on the Desktop screen as the "Status." The common operational states are described in the table below. See Figure 55 on page 42 and the Sequence Of Operation on page 54.

**TABLE 12**

State	Description
Standby	The water heater is not in an active heating cycle. IE: the Tank Temperature is at or above the Operating Set Point.
Input Verification	The control system is conducting a diagnostic check at the beginning of a heating cycle.
Short Cycle Delay	The control system is waiting for a pre-defined time period to expire before initiating a heating cycle. This prevents "short-cycling" which can greatly accelerate wear on components such as the Hot Surface Igniter and Combustion Blower. <b>NOTE:</b> If the control system is in this operational state increase the Differential setting in the Temperatures menu to lengthen heating cycles.
Pre-Purge	The Combustion Blower is energized to flush residual flue gases from the combustion chamber prior to ignition.
Igniter Warm Up	The Hot Surface Igniter is energized and is currently warming up to ensure proper ignition. See the Sequence Of Operation on page 54 for minimum current (AC amps) information.
Ignition Activation	The 24 VAC Gas Valve is energized and opens to allow fuel gas to flow to the Main Burner.
Ignition Verification	The control system is monitoring the flame sensor for the required minimum flame sensing current. See the Sequence Of Operation on page 54 for minimum flame sensing current (DC micro amps) information.
Inter-Purge	The Combustion Blower is energized to flush residual fuel gas from the combustion chamber after a failed ignition attempt.
Heating	Ignition was successful, flame sensing current has been established. The water in the storage tank is being heated.
Post-Purge	The Combustion Blower is energized to flush residual flue gases from the combustion chamber at the end of a heating cycle.
Fault	The control system has detected a Fault condition. Heating operation is disabled until the Fault condition is corrected. Power to the water heater must be cycled off and on to reset the control system. <b>NOTE:</b> Cycling power will not reset the control system if the condition that caused the Fault has not been corrected.

## CONTROL SYSTEM MENUS

From the Desktop screen pressing the Operational directly below "Menu" on the LCD will display the "Main Menu" this is where all control system menus are located. The table below describes the control system menus.

**TABLE 13**

Menu	Description
Temperatures	Most commonly accessed menu. Contains the Operating Set Point and Differential user settings.
Heater Status	This menu displays the current state of all pressure switches and the ECO (open/closed). The on/off status of the Combustion Blower, gas valve, igniter, flame sensor and other monitored water heater components are displayed in this menu.
Display Settings	Temperature units (°F or °C), the LCD appearance (brightness/contrast) and backlight delay user adjustable settings are located in this menu.
Heater Information	Elapsed time of operation, total heating cycle time, heating cycle count, heating on time along with UIM and CCB software revisions can be viewed in this menu.
Current Fault	Displays any current Alert or Fault messages.
Fault History	This control system menu retains a list of the last nine (9) Fault and Alert messages with a time stamp. The newest event will replace the oldest.
Fault Occurrence	This control system menu retains a running total of how many times each Fault condition has occurred since the water heater was first installed.
Restore Factory Defaults	This control system feature allows the user to restore control system user settings to their factory default settings. Display Settings preferences ARE NOT changed when factory defaults are restored.
Help Screens	Text based operational and user information explaining how to change user settings, navigate the control system menus and icon descriptions.

## USER SETTINGS & CONTROL SYSTEM MENUS

### TEMPERATURES MENU

#### Operating Set Point And Differential Adjustment

The Operating Set Point is adjustable from 90°F (42°C) to 180°F (82°C). The factory setting is 120°F (49°C). The Differential is adjustable from 2° to 20°. The factory setting is 8°. These user settings are accessed from the Temperatures menu. The following instructions will explain how to adjust these settings and navigate the control system menus.

When the water temperature sensed by the control system from the two (upper and lower) Temperature Probes reaches the Operating Set Point the control system will end the heating cycle. A heating cycle will be activated again when the sensed water temperature drops below the Operating Set Point minus the Differential setting.

**NOTE:** Lower Differential settings may cause excessive heating cycles (short-cycling) which can cause premature failure of components such as the Hot Surface Igniter. Set the Differential at the highest setting which produces an acceptable hot water supply. Set the Operating Set Point to the lowest setting which produces an acceptable hot water supply for most efficient use.

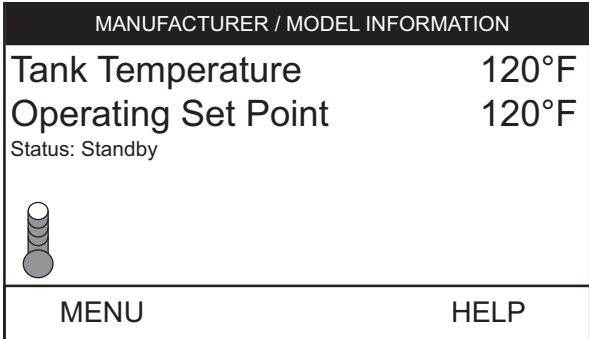
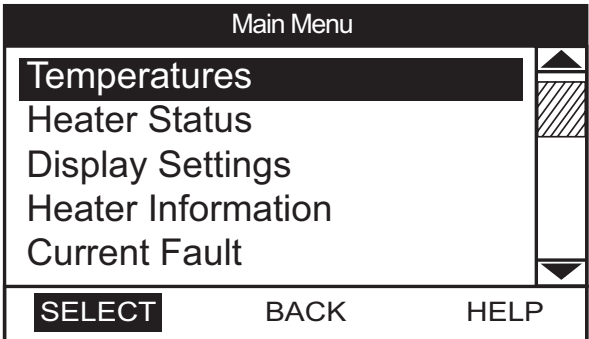
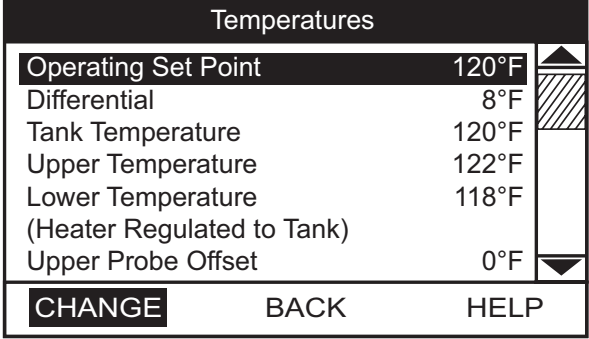
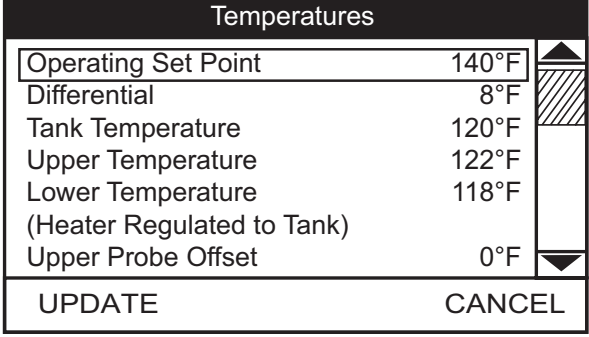
DESCRIPTION/ACTION	DISPLAY
<p>From the Desktop screen, press the Operational Button under MENU. The "Main Menu" screen will be displayed.</p>	 <p>MANUFACTURER / MODEL INFORMATION</p> <p>Tank Temperature 120°F</p> <p>Operating Set Point 120°F</p> <p>Status: Standby</p> <p>MENU HELP</p>
<p>The Main Menu is where all control system menus are listed, see Table 13 on page 44 for a complete list and description of control system menus. Use the Up and Down Buttons to view all control system menus from the Main Menu.</p> <p>With Temperatures menu selected (highlighted in black) in the Main Menu screen, press the Operational Button under "SELECT" to enter the Temperatures menu.</p> <p>If the Temperatures menu is not selected use the Up and Down Buttons to select this menu item.</p>	 <p>Main Menu</p> <p>Temperatures</p> <p>Heater Status</p> <p>Display Settings</p> <p>Heater Information</p> <p>Current Fault</p> <p>SELECT BACK HELP</p>
<p>With the Operating Set Point selected in the Temperatures menu, press the Operational Button underneath "CHANGE" to activate the adjustment mode for this menu item.</p> <p>If Operating Set Point is not selected use the Up and Down Buttons to select this menu item.</p> <p><b>NOTE:</b> Higher Temperature settings increase wear and operating costs. Set the Operating Set Point to the lowest setting which produces an acceptable hot water supply. This will always provide the most energy efficient operation and longer life.</p>	 <p>Temperatures</p> <p>Operating Set Point 120°F</p> <p>Differential 8°F</p> <p>Tank Temperature 120°F</p> <p>Upper Temperature 122°F</p> <p>Lower Temperature 118°F</p> <p>(Heater Regulated to Tank)</p> <p>Upper Probe Offset 0°F</p> <p>CHANGE BACK HELP</p>
<p>With the adjustment mode for the Operating Set Point activated the selection bar will change from a black fill to a black outline.</p> <p>Use the Up and Down Buttons to change the current setting.</p> <p>Press the Operational Button under "UPDATE" to save the new setting. Press the Operational Button under "CANCEL" to discard changes and return to the previously saved setting.</p> <p><b>NOTE:</b> Use this same procedure to change the Differential setting and other adjustable user settings in the control system menus.</p>	 <p>Temperatures</p> <p>Operating Set Point 140°F</p> <p>Differential 8°F</p> <p>Tank Temperature 120°F</p> <p>Upper Temperature 122°F</p> <p>Lower Temperature 118°F</p> <p>(Heater Regulated to Tank)</p> <p>Upper Probe Offset 0°F</p> <p>UPDATE CANCEL</p>

**TEMPERATURES MENU (CONT)**

DESCRIPTION/ACTION	DISPLAY																																				
<ul style="list-style-type: none"> <li>• <b>Tank Temperature</b> - non adjustable - control system sensed temperature (averaged from upper and lower temperature probes).</li> <li>• <b>Upper Temperature</b> - non adjustable - control system sensed temperature from the Upper Temperature Probe.</li> <li>• <b>Lower Temperature</b> - non adjustable - control system sensed temperature from the Lower Temperature Probe.</li> <li>• <b>(Heater Regulated to Tank)</b> - non adjustable - configuration information.</li> <li>• <b>Upper Probe &amp; Lower Probe Offset</b> - adjustable user setting, range -5° to +5° (factory setting 0°).</li> </ul> <p><b>NOTE:</b> These settings should only be used if the hot water supply temperature varies greatly from the Operating Set Point setting.</p> <p>The Upper and Lower Probe Offsets are used to calibrate control system temperature sensing. This can improve the precision of temperature control in the storage tank and at points of use. This feature can also be used to compensate for building recirculation loops (hot water returning to the storage tank) that may cause the heating cycles to terminate prematurely.</p> <p>Example: If the current sensed temperature from a temperature probe is 120°F (49°C) and the Offset setting for that probe is adjusted to a value other than 0°, the control system would calibrate or “offset” the sensed temperature from the probe and the averaged tank temperature. Heating cycles would be activated and deactivated based on the calibrated (offset) temperature.</p> <p>These settings are adjusted in the same way described for the Operating Set Point And Differential Adjustment on page 45.</p>	<div style="text-align: center;">Top of Menu</div> <table border="1" style="width: 100%; border-collapse: collapse;"> <thead> <tr> <th colspan="2" style="background-color: black; color: white; text-align: center;">Temperatures</th> </tr> </thead> <tbody> <tr> <td style="background-color: black; color: white;">Operating Set Point</td> <td style="text-align: right;">140°F ▲</td> </tr> <tr> <td>Differential</td> <td style="text-align: right;">8°F ▨</td> </tr> <tr> <td>Tank Temperature</td> <td style="text-align: right;">120°F</td> </tr> <tr> <td>Upper Temperature</td> <td style="text-align: right;">122°F</td> </tr> <tr> <td>Lower Temperature</td> <td style="text-align: right;">118°F</td> </tr> <tr> <td>(Heater Regulated to Tank)</td> <td></td> </tr> <tr> <td>Upper Probe Offset</td> <td style="text-align: right;">0°F ▼</td> </tr> <tr> <td style="text-align: center;">CHANGE</td> <td style="text-align: center;">BACK      HELP</td> </tr> </tbody> </table> <div style="text-align: center;">Bottom of Menu</div> <table border="1" style="width: 100%; border-collapse: collapse;"> <thead> <tr> <th colspan="2" style="background-color: black; color: white; text-align: center;">Temperatures</th> </tr> </thead> <tbody> <tr> <td>Differential</td> <td style="text-align: right;">8°F ▲</td> </tr> <tr> <td>Tank Temperature</td> <td style="text-align: right;">120°F</td> </tr> <tr> <td>Upper Temperature</td> <td style="text-align: right;">122°F</td> </tr> <tr> <td>Lower Temperature</td> <td style="text-align: right;">118°F</td> </tr> <tr> <td>(Heater Regulated to Tank)</td> <td></td> </tr> <tr> <td style="background-color: black; color: white;">Upper Probe Offset</td> <td style="text-align: right;">0°F ▨</td> </tr> <tr> <td>Lower Probe Offset</td> <td style="text-align: right;">0°F ▼</td> </tr> <tr> <td style="text-align: center;">CHANGE</td> <td style="text-align: center;">BACK      HELP</td> </tr> </tbody> </table>	Temperatures		Operating Set Point	140°F ▲	Differential	8°F ▨	Tank Temperature	120°F	Upper Temperature	122°F	Lower Temperature	118°F	(Heater Regulated to Tank)		Upper Probe Offset	0°F ▼	CHANGE	BACK      HELP	Temperatures		Differential	8°F ▲	Tank Temperature	120°F	Upper Temperature	122°F	Lower Temperature	118°F	(Heater Regulated to Tank)		Upper Probe Offset	0°F ▨	Lower Probe Offset	0°F ▼	CHANGE	BACK      HELP
Temperatures																																					
Operating Set Point	140°F ▲																																				
Differential	8°F ▨																																				
Tank Temperature	120°F																																				
Upper Temperature	122°F																																				
Lower Temperature	118°F																																				
(Heater Regulated to Tank)																																					
Upper Probe Offset	0°F ▼																																				
CHANGE	BACK      HELP																																				
Temperatures																																					
Differential	8°F ▲																																				
Tank Temperature	120°F																																				
Upper Temperature	122°F																																				
Lower Temperature	118°F																																				
(Heater Regulated to Tank)																																					
Upper Probe Offset	0°F ▨																																				
Lower Probe Offset	0°F ▼																																				
CHANGE	BACK      HELP																																				

**HEATER STATUS MENU**

DESCRIPTION/ACTION	DISPLAY																																				
<p>Select Heater Status from the Main Menu and press the Operational Button under "SELECT" to enter this menu. This menu contains non adjustable operational information. Use the Up &amp; Down Buttons to navigate the menu.</p> <ul style="list-style-type: none"> <li>• <b>Status</b> - displays the current Operating State, see Table 12 on page 44.</li> <li>• <b>ECO Contact, Low Gas PS, Blocked Inlet PS, Blocked Outlet PS, Blower Prover PS</b> - displays the current state of the switch contacts; open or closed.</li> <li>• <b>Blower On, Igniter On, Gas Valve On</b> - displays whether or not the control system is currently energizing these water heater components; yes = energized, no = de-energized.</li> <li>• <b>Igniter Current</b> - displays whether or not the control system has detected the required minimum current, see Sequence Of Operation on page 54.</li> <li>• <b>Flame Detected</b> - displays whether or not the control system has detected Main Burner flame during ignition from the flame sensor.</li> <li>• <b>External Input Enable</b> - displays whether or not the S1 dipswitches have been configured to activate the enable/disable circuit, see Enable/Disable Circuit on page 39.</li> <li>• <b>Ignition Trials</b> - displays whether or not the S1 dipswitches have been configured to allow 1 or 3 trials for ignition before declaring an "Ignition Failure" Fault condition, see the CCB - Central Control Board Layout on page 63.</li> </ul>	<div style="text-align: center;">Top of Menu</div> <table border="1" style="width: 100%; border-collapse: collapse;"> <thead> <tr> <th colspan="2" style="background-color: black; color: white; text-align: center;">Heater Status</th> </tr> </thead> <tbody> <tr> <td>Status</td> <td style="text-align: right;">Standby ▲</td> </tr> <tr> <td>ECO Contact</td> <td style="text-align: right;">Closed ▨</td> </tr> <tr> <td>Low Gas PS</td> <td style="text-align: right;">Closed</td> </tr> <tr> <td>Blocked Inlet PS</td> <td style="text-align: right;">Closed</td> </tr> <tr> <td>Blocked Outlet PS</td> <td style="text-align: right;">Closed</td> </tr> <tr> <td>Blower Prover PS</td> <td style="text-align: right;">Open</td> </tr> <tr> <td>Blower On</td> <td style="text-align: right;">No ▼</td> </tr> <tr> <td style="text-align: center;">BACK</td> <td style="text-align: center;">HELP</td> </tr> </tbody> </table> <div style="text-align: center;">Bottom of Menu</div> <table border="1" style="width: 100%; border-collapse: collapse;"> <thead> <tr> <th colspan="2" style="background-color: black; color: white; text-align: center;">Heater Status</th> </tr> </thead> <tbody> <tr> <td>Blower On</td> <td style="text-align: right;">No ▲</td> </tr> <tr> <td>Igniter On</td> <td style="text-align: right;">No</td> </tr> <tr> <td>Igniter Current</td> <td style="text-align: right;">No</td> </tr> <tr> <td>Gas Valve On</td> <td style="text-align: right;">No</td> </tr> <tr> <td>Flame Detected</td> <td style="text-align: right;">No</td> </tr> <tr> <td>External Input Enable</td> <td style="text-align: right;">No ▨</td> </tr> <tr> <td>Ignition Trials</td> <td style="text-align: right;">3 ▼</td> </tr> <tr> <td style="text-align: center;">BACK</td> <td style="text-align: center;">HELP</td> </tr> </tbody> </table>	Heater Status		Status	Standby ▲	ECO Contact	Closed ▨	Low Gas PS	Closed	Blocked Inlet PS	Closed	Blocked Outlet PS	Closed	Blower Prover PS	Open	Blower On	No ▼	BACK	HELP	Heater Status		Blower On	No ▲	Igniter On	No	Igniter Current	No	Gas Valve On	No	Flame Detected	No	External Input Enable	No ▨	Ignition Trials	3 ▼	BACK	HELP
Heater Status																																					
Status	Standby ▲																																				
ECO Contact	Closed ▨																																				
Low Gas PS	Closed																																				
Blocked Inlet PS	Closed																																				
Blocked Outlet PS	Closed																																				
Blower Prover PS	Open																																				
Blower On	No ▼																																				
BACK	HELP																																				
Heater Status																																					
Blower On	No ▲																																				
Igniter On	No																																				
Igniter Current	No																																				
Gas Valve On	No																																				
Flame Detected	No																																				
External Input Enable	No ▨																																				
Ignition Trials	3 ▼																																				
BACK	HELP																																				

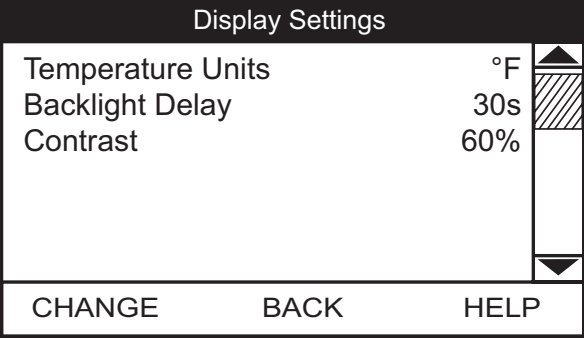

## DISPLAY SETTINGS

DESCRIPTION/ACTION	DISPLAY
<p>Select Display Settings from the Main Menu and press the Operational Button under "SELECT" to enter this menu. This menu contains adjustable display options for viewing information on the UIM's LCD screen. Use the Up &amp; Down Buttons to navigate the menu.</p> <ul style="list-style-type: none"> <li>• <b>Temperature Units</b> - Adjustable user setting that changes temperature units display to Celsius °C or Fahrenheit °F.</li> <li>• <b>Backlight Delay</b> - Adjustable user setting that determines how long the UIM's LCD backlight remains illuminated after a key has been pressed. Available settings are; Always Off, 10, 30 or 60 seconds and Always On.</li> <li>• <b>Contrast</b> - Adjustable user setting to adjust the UIM's LCD screen contrast between text and background.</li> </ul> <p><b>NOTE:</b> These settings are adjusted in the same way described for the Operating Set Point And Differential Adjustment on page 45.</p>	

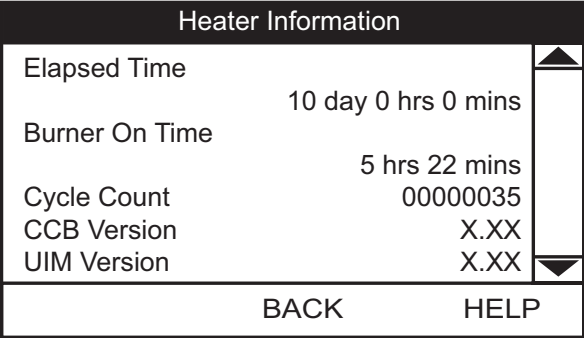
## HEATER INFORMATION

DESCRIPTION/ACTION	DISPLAY
<p>Select Heater Information from the Main Menu and press the Operational Button under "SELECT" to enter this menu. This menu contains non adjustable operational information.</p> <ul style="list-style-type: none"> <li>• <b>Elapsed Time</b> - Total accumulated time the control system (water heater) has been energized.</li> <li>• <b>Burner On Time</b> - Total accumulated time the control system has been in the heating operating state; burner run time.</li> <li>• <b>Cycle Count</b> - Total accumulated count of heating cycles.</li> <li>• <b>CCB Version</b> - Software version for central control board.</li> <li>• <b>UIM Version</b> - Software version for user interface module.</li> </ul> <p><b>NOTE:</b> Historical data is stored in the CCB's memory. If this CCB is replaced during servicing the historical data on the CCB being replaced will be lost. The data stored in the new circuit board will no longer reflect the entire history of the water heater.</p> <p>The Elapsed Time, Burner On Time and Cycle Count indicate age, usage and wear.</p> <p>If the Cycle Count per day is high (divide cycle count by days to determine cycles per day) or the cycle duration is short (determine burner on time total minutes, divide burner on time total minutes by cycle count) consider raising the Differential setting to avoid short cycling and excessive component wear, see Operating Set Point And Differential Adjustment on page 45.</p> <p>This historical data can also be used to assist facilities managers in forecasting planned replacement of equipment to help avoid lengthy and costly hot water supply interruptions.</p>	

**CURRENT FAULT**

DESCRIPTION/ACTION	DISPLAY
<p>Select Current Fault from the Main Menu and press the Operational Button under "SELECT" to enter this menu. This menu contains non adjustable operational information. Use the Up &amp; Down Buttons to navigate the menu.</p> <p>This menu contains the current Fault or Alert error message. The time the Fault or Alert message occurred appears directly below. A brief description of what causes the particular Fault or Alert condition appears below that. Pressing the Operational Button under "ADVANCED" will give more detailed service information and a list of possible causes for the Fault or Alert condition. See Fault And Alert Messages on page 58 for more detailed information and diagnostic procedures.</p> <p>If there is no Fault or Alert condition active this menu will not contain any information, "(none)" will be shown next to Current Fault in the Main menu.</p>	<div style="border: 1px solid black; padding: 10px;"> <p style="text-align: center;"><b>Blocked Exhaust</b></p> <p style="text-align: center; font-size: small;">Fault occurred 2 mins ago</p> <div style="display: flex; justify-content: space-between; align-items: center;">  <div style="text-align: center;"> <p>The exhaust is blocked or restricted. Ensure condensate hose is draining.</p> <p>Call a service professional: Your Company Name Here (press [DOWN] for more....)</p> </div>  </div> <div style="display: flex; justify-content: space-around; margin-top: 10px;"> <span>BACK</span> <span>ADVANCED</span> </div> </div>

**FAULT HISTORY**

DESCRIPTION/ACTION	DISPLAY												
<p>Select Fault History from the Main Menu and press the Operational Button under "SELECT" to enter this menu. This menu contains non adjustable operational information. Use the Up &amp; Down Buttons to navigate the menu.</p> <p>This menu contains a list of the last nine (9) Fault and Alert messages with a time stamp. The newest event will replace the oldest.</p> <p>Press the Operational Button under "VIEW" to view details for each Fault or Alert message stored.</p>	<div style="border: 1px solid black; padding: 10px;"> <p style="text-align: center;"><b>Fault History</b></p> <table style="width: 100%; border-collapse: collapse;"> <tr> <td style="width: 5%;">1:</td> <td style="width: 70%;">Blocked Air Intake (A7)</td> <td style="width: 25%; text-align: right;">51 mins ago</td> </tr> <tr> <td>2:</td> <td>Blocked Exhaust (A8)</td> <td style="text-align: right;">54 mins ago</td> </tr> <tr> <td>3:</td> <td>Low Gas Pressure (A6)</td> <td style="text-align: right;">57 mins ago</td> </tr> <tr> <td>4:</td> <td>Blower Prover Failure (AC)</td> <td></td> </tr> </table> <div style="display: flex; justify-content: space-around; margin-top: 10px;"> <span>VIEW</span> <span>BACK</span> <span>HELP</span> </div> </div>	1:	Blocked Air Intake (A7)	51 mins ago	2:	Blocked Exhaust (A8)	54 mins ago	3:	Low Gas Pressure (A6)	57 mins ago	4:	Blower Prover Failure (AC)	
1:	Blocked Air Intake (A7)	51 mins ago											
2:	Blocked Exhaust (A8)	54 mins ago											
3:	Low Gas Pressure (A6)	57 mins ago											
4:	Blower Prover Failure (AC)												

**FAULT OCCURRENCE**

DESCRIPTION/ACTION	DISPLAY																					
<p>Select Fault Occurrence from the Main Menu and press the Operational Button under "SELECT" to enter this menu. This menu contains non adjustable operational information. Use the Up &amp; Down Buttons to navigate the menu.</p> <p>This menu contains a running total of how many times each Fault condition has occurred since the water heater was first installed.</p> <p><b>NOTE:</b> Historical data is stored in the CCB's memory. If this CCB is replaced during servicing the historical data on the CCB being replaced will be lost. The data stored in the new circuit board will no longer reflect the entire history of the water heater.</p>	<div style="border: 1px solid black; padding: 10px;"> <p style="text-align: center;"><b>Fault Occurrence</b></p> <table style="width: 100%; border-collapse: collapse;"> <tr> <td style="width: 70%;">Ignition Failure</td> <td style="width: 10%; text-align: center;">10</td> <td style="width: 20%;"></td> </tr> <tr> <td>ECO</td> <td style="text-align: center;">0</td> <td></td> </tr> <tr> <td>Low Gas Pressure</td> <td style="text-align: center;">10</td> <td></td> </tr> <tr> <td>Blocked Intake Air</td> <td style="text-align: center;">0</td> <td></td> </tr> <tr> <td>Blocked Exhaust</td> <td style="text-align: center;">0</td> <td></td> </tr> <tr> <td>Thermostat Input 4</td> <td style="text-align: center;">0</td> <td></td> </tr> <tr> <td>Blower Prover</td> <td style="text-align: center;">3</td> <td></td> </tr> </table> <div style="display: flex; justify-content: space-around; margin-top: 10px;"> <span>BACK</span> <span>HELP</span> </div> </div>	Ignition Failure	10		ECO	0		Low Gas Pressure	10		Blocked Intake Air	0		Blocked Exhaust	0		Thermostat Input 4	0		Blower Prover	3	
Ignition Failure	10																					
ECO	0																					
Low Gas Pressure	10																					
Blocked Intake Air	0																					
Blocked Exhaust	0																					
Thermostat Input 4	0																					
Blower Prover	3																					



**RESTORE FACTORY DEFAULTS**

DESCRIPTION/ACTION	DISPLAY
<p>Select Restore Factory Defaults from the Main Menu and press the Operational Button under "SELECT" to enter this menu.</p> <p>To restore the adjustable user settings to their factory default settings press the Operational Button underneath "YES." The display will show text confirming the factory default settings have been restored.</p> <p>Press the Operational Button underneath "BACK" to exit the Restore Factory Defaults menu.</p>	<div style="border: 1px solid black; padding: 10px;"> <p style="text-align: center;"><b>Restore Factory Defaults</b></p> <div style="display: flex; justify-content: space-between; align-items: center;">  <div style="text-align: center;"> <p>Are you sure you want to restore the system to factory defaults?</p> </div> </div> <div style="display: flex; justify-content: space-around; margin-top: 20px;"> <span>YES</span> <span>NO</span> </div> </div>

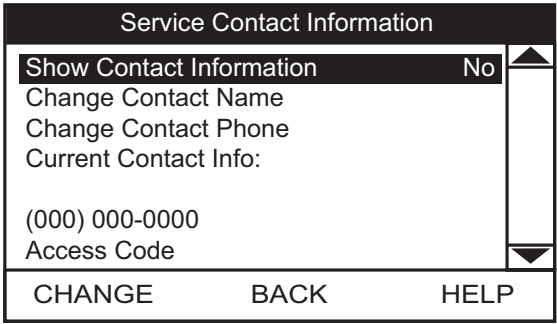
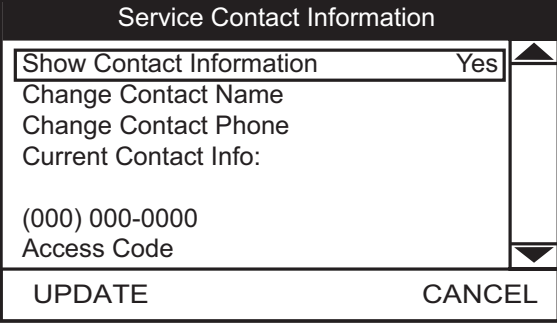
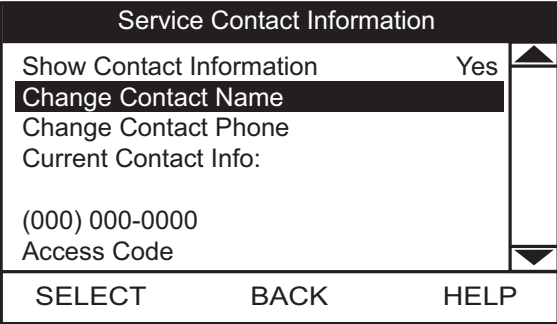
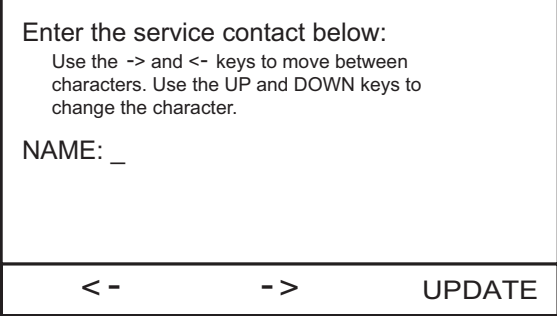

**SERVICE CONTACT INFORMATION**

The control system has a discrete menu that Installing contractors and/or service agents can access to enter contact information for their customers. This contact information will be displayed with all Fault and Alert messages.

DESCRIPTION/ACTION	DISPLAY
<p>From the Desktop Screen (see Figure 55 on page 42) press and hold down the middle (unmarked) Operational Button for 30 seconds and then release it.</p> <p>This will launch a discrete menu where personalized contact information can be entered.</p> <p>Using the UP and DOWN buttons select (highlighted in black) the "Show Contact Information" menu item.</p> <p>Press the Operational Button under "CHANGE" to activate the adjustment mode for this parameter.</p>	
<p>With the adjustment mode for "Show Contact Information" activated the selection bar will change from a black fill to a black outline.</p> <p>Use the Up and Down Buttons to change the setting from "No" to "Yes" and press the Operational Button underneath "UPDATE" to save the new setting.</p> <p><b>NOTE:</b> The Access Code at the bottom of the Service Contact Information screen is for manufacturing engineering purposes only. There are no user settings or information accessed through this menu item.</p>	
<p>Using the UP and DOWN buttons select (highlighted in black) the "Change Contact Name" menu item.</p> <p>Press the Operational Button under "SELECT" to open the Change Contact Name menu.</p>	
<p>Follow the on screen instructions to enter your name or the name of your company. There is a maximum of 20 character spaces for this purpose.</p> <p>When finished press the Operational Button "UPDATE" to save the new Contact Name. The control system will return to the discrete menu.</p>	
<p>Using the UP and DOWN buttons select (highlighted in black) the "Change Contact Phone" menu item and press the Operational Button under "SELECT".</p> <p>Follow the on screen instructions to enter a new Contact Phone number and press the Operational Button under "UPDATE" to save the new phone number.</p> <p>When the new Contact Name and Contact Phone number have both been updated, press the Operational Button under "BACK" to return to the Desktop screen.</p>	

# START UP

## PRIOR TO START UP

Installation and start up of this water heater requires abilities and skills equivalent to that of a licensed tradesman in the field involved, see Qualifications on page 6.

Do not place the water heater in operation if any part has been under water. Immediately call a qualified service technician to inspect the water heater and to replace any part of the control system and any gas control which has been under water.

Light the water heater in accordance with the Lighting and Operation Instruction label on the water heater and in this manual on page 53.

The water heaters covered by this manual are equipped with an electronic control system (see page 42) which automatically sequences the Combustion Blower, pre and post purging of the combustion chamber, the Hot Surface Igniter, the 24 VAC Gas Valve, Main Burner ignition, and flame sensing. The control system will lock out after three unsuccessful ignition attempts.

Before attempting start up, thoroughly study and familiarize yourself with the exact Sequence Of Operation, see the written Sequence Of Operation on page 54 and the Sequence Of Operation Flow Chart on page 55.

Be certain that the water heater is full of water, that air is purged from the gas and water lines and that there are no leaks in the gas and water lines. Ensure all inlet water valves are open.

## FILLING THE WATER HEATER

Follow these steps to fill the water heater prior to start up.

1. Close the heater drain valve.
2. Open a nearby hot water faucet to permit the air in the system to escape.
3. Fully open the cold water inlet valve allowing the piping and water heater to fill with water.
4. Close the hot water faucet opened in Step 2 as water starts to flow.

## SUPPLY GAS LINE PURGING

### **WARNING**

#### Fire or Explosion Hazard

- Gas line purging is required with new piping or systems in which air has entered.
- To avoid risk of fire or explosion purge discharge must not enter into confined areas or spaces where ignition can occur.
- The area must be well ventilated and all sources of ignition must be deactivated or removed.
- Use only the gas shown on the water heater rating label.
- Keep ignition sources away from faucets after extended periods of non-use.



Read instruction manual before installing, using or servicing water heater.



1. Close the Main Gas Shutoff Valve, see Figure 52 on page 37.
2. Purge all air from the supply gas line up to the water heater's Main Gas Shutoff Valve.

3. When all air has been purged from the supply gas line, tighten all supply gas line connections.
4. Check for gas leaks, see Gas Line Leak Testing on page 38, and repair any leaks found.

## INITIAL START UP

### REQUIRED TEST EQUIPMENT

- Two U-tube manometers, recommended ranges; 0-14" W.C. (0-3.5 kPa) and 0-35" W.C. (0-8.7 kPa) or pressure gauges.
- Two digital manometers can be used in place of U-tube manometers or pressure gauges. Recommended ranges; -14.00 to +14.00" W.C. (0-3.5 kPa) resolution 0.01" W.C. and 0-35" W.C. (0-8.7 kPa) resolution 0.10" W.C.

**NOTE:** All test equipment must be acclimated to ambient temperature before calibration and use.

### PREPARATION

1. Using the control system menus, change the Operating Set Point to the lowest temperature setting, see Operating Set Point And Differential Adjustment on page 45.
2. Turn the water heater's on/off switch to the "off" position.
3. Close the Main Gas Shut Off Valve, see Figure 52 on page 37.
4. Push in the gas control knob slightly and turn to the "off" position, see Figure 56 and Figure 57 on pages 51 and 52.
5. Wait five (5) minutes for any residual gas to clear.
6. Connect one manometer (higher range) to an available test port on the supply gas line at the water heater. There is a 1/8" NPT Tee fitting and pipe nipple installed for the Low Gas Pressure switch on the inlet side of the 24 VAC Gas Valve with a 1/8" NPT plug for this purpose.
7. Connect one manometer (lower range) to the manifold gas pressure tap at the outlet of the 24 VAC Gas Valve, see Figure 56 on page 51 and Figure 57 on page 52 for location.
8. Open the Main Gas Shutoff Valve.
9. Measure and record the supply gas pressure, this is a "static" supply gas pressure reading; while the water heater is not firing. Adjust supply gas pressure as necessary, see Supply Gas Pressure Adjustment on page 51.

### LIGHTING THE WATER HEATER

1. Push in the gas control knob slightly and turn to the "on" position, see Figure 56 and Figure 57 on pages 51 and 52.
2. Turn the water heater's on/off switch to the "on" position.
3. Wait for the control system to complete its boot up sequence. The Desktop screen showing the current Operating Set Point and Tank Temperature will be displayed on the control system's LCD when the boot up sequence is complete.
4. Using the control system menus and UIM (user interface module), change the Operating Set Point to a setting higher than the current tank temperature displayed on the control system LCD plus the Differential setting to activate a call for heating. See Control System Operation on page 42.
5. Record the manifold gas pressure when the 24 VAC Gas Valve is energized and the Main Burner is ignited, the animated gas valve icon will be displayed on the Desktop screen of the control system's LCD when the control system energizes the 24 VAC Gas Valve, a animated flame icon will appear when Main Burner ignition is successful, see the Status Icons descriptions in Table 11 on page 43.

- Compare the actual manifold gas pressure reading recorded above to the required minimum/maximum values given in Table 4 on page 13. Adjust manifold gas pressure as necessary, see the instructions that follow.
- Record the supply gas pressure when the 24 VAC Gas Valve is energized and the Main Burner is ignited. This is a "dynamic" gas pressure reading; while the water heater is firing.
- Compare the actual supply gas pressure reading recorded above to the required minimum/maximum values given in Table 4 on page 13. Adjust supply gas pressure as necessary, see the instructions that follow.

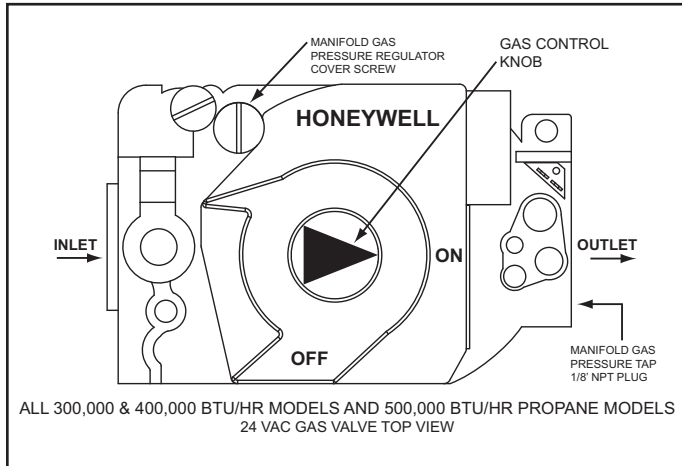



Figure 56

### SUPPLY GAS PRESSURE ADJUSTMENT

	<b>! WARNING</b>
	<b>Fire and Explosion Hazard</b>
	<ul style="list-style-type: none"> <li>Do not use water heater with any gas other than the gas shown on the rating label.</li> <li>Excessive gas pressure to gas valve can cause serious injury or death.</li> <li>Turn off gas lines during installation.</li> <li>Contact a qualified installer or service agency for installation and service.</li> </ul>

Supply gas pressure shall be measured while the water heater is not firing (static pressure) AND while the water heater is firing at full capacity (dynamic pressure).

If the supply gas pressure to the water heater is not between the required minimum and maximum values given in Table 4 on page 13 adjust the supply gas regulator as necessary. Adjust the supply gas regulator(s) per the regulator manufacturer's instructions to achieve the required "static" and "dynamic" supply gas pressure.

#### Multiple Appliance Installations:

In multiple water heater installations or in installations where the installed water heater(s) share a common gas supply main with other gas fired appliances; the supply gas pressures shall be measured at each water heater with all gas fired appliances connected to a common main firing at full capacity.

On multiple water heater installations the supply gas line regulators shall be adjusted to provide gas pressure to each water heater within the minimum and maximum supply pressure requirements listed in Table 4 on page 13 with all gas fired appliances connected

to a common gas main firing at full capacity.

**NOTE:** A pressure drop of more than 1.5" W. C. (0.37 kPa) when the Main Burner ignites is an indication of an inadequate supply of gas and can lead to ignition failure, rough starts and/or rough operation. If a drop of more than 1.5" W. C. (0.37 kPa) in supply gas pressure occurs when the Main Burner ignites, ensure the supply gas lines and regulator(s) are properly sized and installed. See the requirements for Supply Gas Regulator and Supply Gas Line on page 13. See Supply Gas Line Installation on page 37 and Supply Gas Regulator Installation on page 38. Ensure all requirements and installation instructions are maintained.

### MANIFOLD GAS PRESSURE ADJUSTMENT

	<b>! WARNING</b>
	<b>Fire and Explosion Hazard</b>
	<ul style="list-style-type: none"> <li>Under no circumstances should the input exceed the rate shown on the water heater's rating label.</li> <li>Overfiring could result in fire or explosion.</li> <li>Gas and carbon monoxide detectors are available.</li> </ul>

	<b>! WARNING</b>
	<b>Breathing Hazard - Carbon Monoxide Gas</b>
	<ul style="list-style-type: none"> <li>Under no circumstances should the input exceed the rate shown on the water heater's rating label.</li> <li>Overfiring could result in damage to the water heater and sooting.</li> <li>Gas and carbon monoxide detectors are available.</li> </ul>
Breathing carbon monoxide can cause brain damage or death. Always read and understand instruction manual.	

Ensure the "dynamic" supply gas pressure is above the minimum requirements in Table 4 on page 13 before any adjustments are made to the manifold gas pressure. Attempts to adjust manifold gas pressure during periods of low supply gas pressure could result in overfiring when the supply gas pressure returns to normal. See Supply Gas Pressure Adjustment on this page.

If necessary, adjust the manifold gas pressure as follows:

- Follow the instructions for Initial Start Up on page 50 to connect manometers to the supply and manifold gas pressure taps and to start the water heater.
- Remove the manifold gas pressure regulator cover screw, see Figure 56 on this page and Figure 57 on page 52.
- Using a small flat tip screw driver turn the adjustment screw clockwise to increase manifold gas pressure and counter clockwise to decrease manifold gas pressure.

**NOTE:** Turn the manifold gas pressure adjustment screw in small increments (no more than 1/4 turn) and allow the manifold gas pressure to stabilize for several minutes before making further adjustments.

- Replace the gas pressure regulator cover screw.
- Cycle the burner on and off several times to check operation.

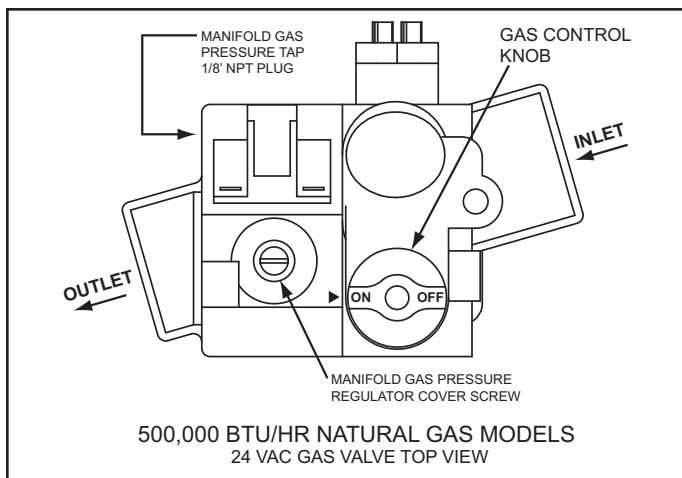

Figure 57

### CHECKING THE FIRING RATE

If firing rate adjustment is required follow these instructions to determine the actual firing rate of the water heater:

1. Ensure there are no other gas fired appliances connected to the gas meter firing during this test.
2. Contact the gas supplier to determine the heating value, in Btu per cubic foot, of the gas supply.
3. Connect a manometer to the manifold gas pressure tap. Follow the instructions for Initial Start Up on page 50.
4. Start the water heater and ensure it is firing.
5. Check the manifold gas pressure, refer to Table 4 on page 13 for correct pressure. See Manifold Gas Pressure Adjustment on page 51 if adjustment is necessary.
6. Locate the gas meter serving the water heater.
7. Time how long (in seconds) it takes for one cubic foot of gas to be used while the water heater is firing with a stop watch.
8. Use the formula below to “clock” the gas meter and determine the actual firing rate of the water heater based on the heating value (Btu per cubic foot) of the gas supply:

$$\frac{3600}{T} \times H = \text{Btu/hr}$$

Example:

$$\frac{3600}{12.6} \times 1050 = 300,000 \text{ Btu/hr (87.9 kW)}$$

- 3600 = seconds in one hour.
- T = time, in seconds, to burn one cubic foot of gas.
- H = heating value of gas in Btu per cubic foot.
- Btu/hr = actual firing rate of the water heater.

**NOTE:** 1050 Btu per cubic foot is a standard value for natural gas. Standard propane gas Btu content is 2500 Btu per cubic foot. Btu values may change in certain areas and at high elevations. Check with the local gas utility company.

### TO TURN OFF GAS

1. Change the Operating Set Point to the lowest temperature setting, see Operating Set Point And Differential Adjustment on page 45.
2. When the water heater has completed its shut down sequence and enters the standby mode, turn the water heater’s on/off switch to the “off” position.
3. Push in the gas control knob slightly and turn to the “off” position, see Figure 56 on page 51 and Figure 57 on this page.
4. Close the Main Gas Shutoff Valve, see Figure 52 on page 37.

### HIGH ALTITUDE INSTALLATIONS

	<b>⚠ WARNING</b>
	<b>Fire and Explosion Hazard</b>
	<ul style="list-style-type: none"> <li>• Under no circumstances should the input exceed the rate shown on the water heater’s rating label.</li> <li>• Overfiring could result in fire or explosion.</li> <li>• Gas and carbon monoxide detectors are available.</li> </ul>

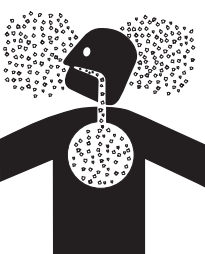
	<b>⚠ WARNING</b>
	<b>Breathing Hazard - Carbon Monoxide Gas</b>
	<ul style="list-style-type: none"> <li>• Under no circumstances should the input exceed the rate shown on the water heater’s rating label.</li> <li>• Overfiring could result in damage to the water heater and sooting.</li> <li>• Gas and carbon monoxide detectors are available.</li> </ul>
Breathing carbon monoxide can cause brain damage or death. Always read and understand instruction manual.	

The water heaters covered by this manual are certified for use without modification for altitudes up to 10,000 feet.

Most gas utility companies de-rate their gas for high altitudes, making it unnecessary to install high altitude orifices.

For installations above 10,000 feet call the technical support phone number listed on the back cover of this manual for further technical assistance. Call the local gas or utility company to verify Btu per cubic foot content before calling for technical assistance and have that information available.

**NOTE:** The actual firing rate of the water heater must not exceed the input rating on the water heater’s rating label under any circumstances.

**NOTE:** Due to the input rating reduction at high altitudes, the output rating of the appliance is also reduced and should be compensated for in the sizing of the equipment for applications.

# LIGHTING THE WATER HEATER

## LIGHTING & OPERATION LABEL

The instruction label below is affixed to the water heater's covered by this manual at the factory and must be followed when lighting and operating the water heater.

### FOR YOUR SAFETY READ BEFORE OPERATING



**WARNING** IF YOU DO NOT FOLLOW THESE INSTRUCTIONS EXACTLY A FIRE OR EXPLOSION MAY RESULT CAUSING PROPERTY DAMAGE, PERSONAL INJURY OR LOSS OF LIFE.



- A. This appliance does not have a pilot. It is equipped with an ignition device which automatically lights the burner. Do not try to light the burner by hand.
- B. BEFORE OPERATING smell all around the appliance area for gas. Be sure to smell next to the floor because some gas is heavier than air and will settle on the floor.
- “WHAT TO DO IF YOU SMELL GAS”**
- Do not try to light any appliance.
  - Do not touch any electrical switch; do not use any telephone in your building.
  - Immediately call your gas supplier from a neighbor's telephone. Follow the gas supplier's instructions.
  - If you cannot reach your gas supplier, call the fire department.
- C. Use only your hand to push in or turn the gas control knob. Never use tools. If the knob will not push in or turn by hand, don't try to repair it, call a qualified service technician. Force or attempted repair may result in fire or explosion.
- D. Do not use this appliance if any part has been under water. Immediately call a qualified service technician to inspect the appliance and to replace any part of the control system and any gas control which has been under water.

### OPERATING INSTRUCTIONS

1. **STOP!** Read the safety information above on this label.
2. Set thermostat to lowest setting.
3. Turn off all electrical power to the appliance.
4. This appliance is equipped with an ignition device which automatically lights the burner. Do not try to light the burner by hand.
5. Push in gas control knob slightly and turn clockwise to “OFF”.
6. Wait five (5) minutes to clear out any gas. If you then smell gas, **STOP!** Follow “B” in the safety information above on this label. If you don't smell gas, go on to the next step.
7. Turn gas control knob counterclockwise to “ON”.
8. Turn on all electrical power to the appliance.
9. Set thermostat to desired setting.
10. If the appliance will not operate, follow the instructions “To Turn Off Gas To Appliance” and call your service technician or gas supplier.

#### GAS CONTROL KNOB

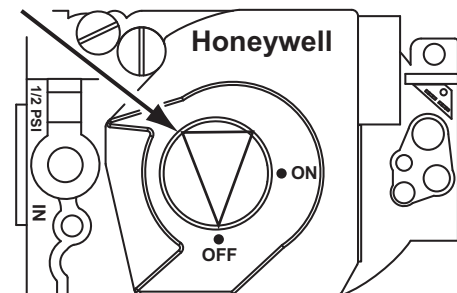

### TO TURN OFF GAS TO APPLIANCE

1. Set the thermostat to lowest setting.
2. Turn off all electrical power to the appliance if service is to be performed.
3. Push in gas control knob slightly and turn clockwise to “OFF”. Do not force.



# TROUBLESHOOTING

## INSTALLATION CHECKLIST

The list below represents some of the most critical installation requirements that, when overlooked, often result in operational problems, down time and needless parts replacement. This is not a complete list. Before performing any troubleshooting procedures use the list below to check for installation errors. Costs to correct installation errors are not covered under the limited warranty. Ensure all installation requirements and instructions in this manual have been maintained and followed.

### WATER HEATER LOCATION

1. Ensure proper clearances to combustibles are maintained and there is sufficient room to service the water heater. See Clearances on page 11.
2. Ensure the area is free of corrosive elements and flammable materials. See the instructions on page 16.

### VENTING

3. Ensure the intake air and/or vent (exhaust) piping is the correct size for the installed length. See Venting Requirements on page 22.
4. Ensure the maximum equivalent feet of pipe has not been exceeded for the intake air and/or vent pipe. See Table 7 on page 22.
5. Ensure the maximum number of elbows has not been exceeded in the intake air and/or vent pipe. See Venting Requirements on page 22.
6. Ensure the balance plate and intake air screen are removed from the intake air connection on the water heater when installing the water heater in a Direct Vent configuration. See Figure 17 on page 24.
7. Ensure all exterior clearances for the intake air, vent and concentric terminations are maintained. See Vertical Termination Installation on page 24, Sidewall Termination Installation on page 26 and Concentric Termination Installation on page 27. These clearances and those cited by local and national codes must be maintained.

### GAS SUPPLY AND PIPING

8. Ensure a supply gas regulator has been installed for each water heater. See the requirements for a Supply Gas Regulator on page 13 and Supply Gas Regulator Installation on page 38.
9. Ensure the supply gas line to each water heater meets the minimum supply gas line size requirements. See the requirements for the Supply Gas Line on page 13 and the installation instructions on page 37 and 38.

### CONDENSATE DRAIN

10. Ensure the condensate drain is properly connected to the exhaust elbow on the water heater with a water trap to prevent vent gases from escaping into the installed space and draining freely to a suitable floor drain. See Figure 9 on page 16 and Condensate Drain Installation on page 36.

### ELECTRICAL CONNECTIONS

11. Ensure the power supply connections to the water heater are polarity correct. See the requirements for the Power Supply on page 13 and Electrical Wiring on page 39.
12. Ensure the water heater is properly grounded. Flame sensing requires an adequate earth ground. If the water heater is not properly grounded it will cause Ignition Failure.

## SEQUENCE OF OPERATION

Read the Sequence of Operation below before attempting to correct any operational problems. Refer to the Features And Components section beginning on page 7 for the location of various water heater components described below. See the Sequence Of Operation Flow Chart on page 55 also.

1. When the control system is first powered, during boot up, it will display water heater model information during initialization. After a few moments the control system LCD which is part of the UIM (user interface module) will display the default screen known as the "Desktop" screen.
2. If the control system determines that the actual water temperature inside the tank is below the programmed Operating Set Point minus the Differential setting, a heating cycle is activated.
3. The control system then performs selected diagnostic system checks. This includes confirming the low gas pressure, blocked exhaust, blocked intake and ECO (energy cut out) switch contacts are closed. The Blower Prover Switch contacts are confirmed open.
4. If all diagnostic checks are successfully passed, the control system energizes the Combustion Blower for pre-purge.
5. The control system must confirm the Blower Prover Switch contacts close after the Combustion Blower is energized.
6. If the Blower Prover Switch contacts are confirmed closed the control system energizes the Hot Surface Igniter for the igniter warm-up period.
7. The control system monitors the igniter current and must sense a minimum of 2.0 AC amps for SUF 130 300 & 400 models and 2.7 AC amps for SUF 130 500 models during the igniter warm up period (12-17 seconds).
8. If igniter amperage is confirmed at or above the required minimum the control system energizes the 24 VAC Gas Valve allowing gas to flow to the Main Burner.
9. The control system de-energizes the Hot Surface Igniter.
10. The control system monitors the flame sensor to confirm a flame is present at the Main Burner. If a flame is not verified during the ignition trial period the control system will try for ignition up to two more times. If flame can not be verified after three trials for ignition, the control system will lock out and display the "Ignition Failure" Fault message.
11. If a flame is verified, the control system will enter the heating mode where it will continue heating the water until the Operating Set Point is reached. At this point, the control system will de-energize the 24 VAC Gas Valve and enter the post-purge cycle (approximately 30 seconds).
12. The Combustion Blower will run for the duration of the post-purge cycle to purge the water heater of all combustion gases. When the post-purge cycle is complete, the blower is de-energized and will coast to a stop.
13. The control system now enters the standby mode while continuing to monitor the internal storage tank water temperature and the state of other system devices. If the tank temperature drops below the Operating Set Point minus the Differential setting, the control will automatically return to Step 2 and repeat the operating cycle.

**SEQUENCE OF OPERATION FLOW CHART**

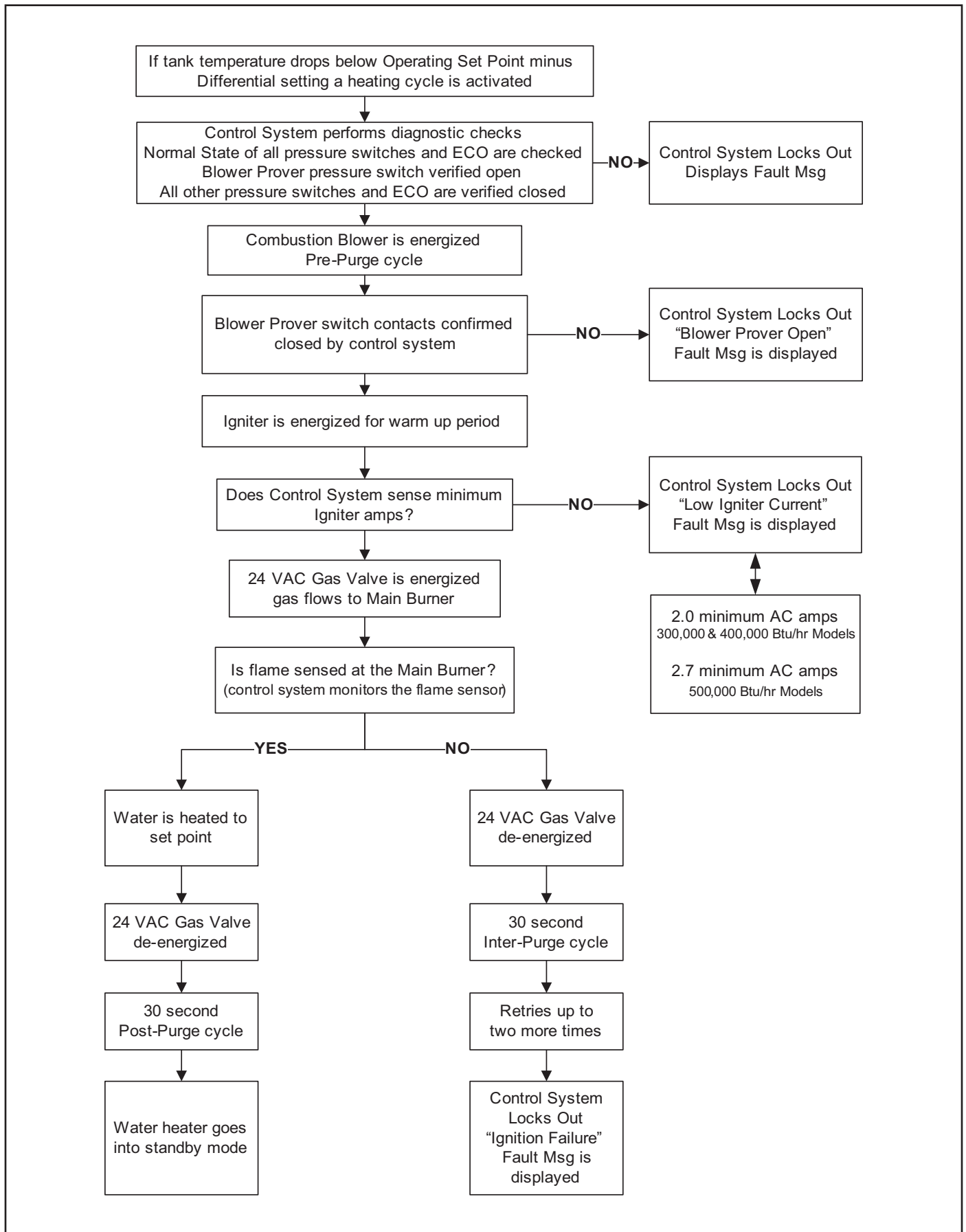

**Figure 58**

## OPERATIONAL PROBLEMS

	 <b>WARNING</b>
	<p>Read and understand this instruction manual and the safety messages herein before installing, operating or servicing this water heater.</p>
	<p>Failure to follow these instructions and safety messages could result in death or serious injury.</p> <p>This manual must remain with the water heater.</p>

This section of the manual is intended to be an aid in correcting common operational problems, it is not all inclusive. The installer may be able to observe and correct certain problems which might arise when the water heater is first put into operation or when it is re-fired after a prolonged shutdown. However, only qualified service agents, as defined in Qualifications on page 6, using appropriate test equipment, should perform any service procedures on the water heater.

**NOTE:** Call the technical support phone number listed on the back cover of this manual for further technical assistance or to locate a qualified service agent in your area.



### INSTALLATION ERRORS

Operational problems on new installations are often the result of installation requirements that have been overlooked rather than failed components. IE: A "Low Gas Pressure" Fault condition is most often caused by low supply gas pressure rather than a defective Low Gas Pressure switch. Rough starting and rough operation are often caused by undersized supply gas lines and/or the absence of a supply gas regulator at the water heater.

Prior to performing any operational checks inspect the water heater installation to ensure all installation requirements and instructions have been maintained and followed. See the Installation Checklist on page 54

**NOTE:** Costs to correct installation errors are not covered under the limited warranty.

### ROUGH STARTING, ROUGH OPERATION

	 <b>WARNING</b>
	<b>Fire and Explosion Hazard</b>
	<ul style="list-style-type: none"> <li>• Do not use water heater with any gas other than the gas shown on the rating label.</li> <li>• Excessive gas pressure to gas valve can cause serious injury or death.</li> <li>• Turn off gas lines during installation.</li> <li>• Contact a qualified installer or service agency for installation and service.</li> </ul>

- Undersized supply gas line (low volume of supply gas) - see Supply Gas Line on page 13.
- Supply gas regulator is not installed per installation requirements (erratic gas supply volume/pressures) - see Supply Gas Regulator on page 13.
- Excessive supply gas pressure - see Table 4 on page 13 and Supply Gas Pressure Adjustment on page 51.

- Excessive manifold gas pressure - see Table 4 on page 13 and Manifold Gas Pressure Adjustment on page 51.
- Vent (exhaust) gas recirculation at the vent and intake air pipe terminations on Direct Vent installations - see Direct Vent Installation on page 23.
- Excessive equivalent lengths of intake air and/or vent (exhaust) piping installed - see Venting Requirements on page 22.
- Debris clogging/blocking the intake air screen(s) - see Figure 17 on page 24 and Figure 22 on page 26.
- Debris clogging/blocking the Main Burner - see Figure 2 on page 7.

### MOMENTARY IGNITION

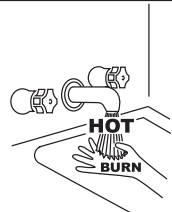
 <b>CAUTION</b>	
<b>Burn Hazard</b>	
	<ul style="list-style-type: none"> <li>• The combustion chamber and burner sleeve and housing become very hot during operation.</li> <li>• Do not reach into the burner housing or combustion chamber if the water heater is still hot.</li> <li>• Allow the water heater to cool and always use gloves when handling the main burner.</li> </ul>

If the Main Burner ignites momentarily but does not sustain ignition allow the water heater to try to ignite up to two more times until control system locks out and the Ignition Failure Fault message is displayed on the control system's LCD. If the water heater is experiencing rough starts - see Rough Starting, Rough Operation on this page. For momentary ignition problems without rough starting check the following:

- Incorrect manifold gas pressure - see Table 4 on page 13 and Manifold Gas Pressure Adjustment on page 51.
- Undersized supply gas line (low volume of supply gas) - see Supply Gas Line on page 13.
- Supply gas regulator is not installed per installation requirements (erratic gas supply volume/pressures) - see Supply Gas Regulator on page 13.
- See the list of possible causes and things to check and repair for the Ignition Failure Fault message on page 58.
- Debris clogging/blocking the intake air screen(s) - see Figure 17 on page 24 and Figure 22 on page 26.
- Debris clogging/blocking the Main Burner - see Figure 2 on page 7.

### NOT ENOUGH OR NO HOT WATER

- No power to the water heater, check breaker, fuses and the water heater on/off switch.
- Hot water supply valve(s) to fixtures closed.
- Operating Set Point is set too low, Differential setting is set too high. See Control System Operation on page 42.
- Upper and/or Lower Probe Offset settings are causing the heating cycles to terminate prematurely - see Temperatures Menu (cont) on page 46.
- Ensure there is not any external supervisory control (using the enable/disable circuit) disabling heating operation. See Enable/Disable Circuit on page 39.
- The heating capacity of the water heater has been exceeded, the water heater is unable to meet demand.

- Colder incoming water temperature lengthening the time required to heat water to desired temperature.
- Hot water piping leaks, open faucets, water heater drain valve leaking or open.
- Sediment or lime scale accumulation may be affecting water heater operation. See Maintenance on page 60 for sediment and lime scale removal procedures.
- Water heater not firing at full input rating. Check manifold gas pressure, see instructions on page 51. Check actual firing rate of the water heater, see instructions on page 52.

#### WATER IS TOO HOT

- Operating Set Point is set too high. See Operating Set Point And Differential Adjustment on page 45.
- Upper and/or Lower Probe Offset settings improperly set - see Temperatures Menu (cont) on page 46.
- Improper water piping - see diagrams beginning on page 67.

#### NOISY OPERATION

- Sediment or lime scale accumulations can cause rumbling and pounding noises during heating cycles. See the Maintenance section of this manual beginning on page 60 for sediment and lime scale removal procedures.
- Normal operating noise of electrical components; Combustion Blower, transformer hum, relay contact closure.

#### WATER LEAKAGE IS SUSPECTED

- Ensure the water heater drain valve is tightly closed.
- Check cleanout opening for leaks - see Figure 4 on page 9.
- Check inlet/outlet water connections and system piping.
- Check the Temperature-Pressure Relief Valve.
  - Excessive water temperature.
  - Excessive water pressure.
  - Defective Temperature-Pressure Relief Valve.

**NOTE:** Excessive water pressure is the most common cause of Temperature-Pressure Relief Valve leakage. Excessive water system pressure is most often caused by "thermal expansion" in a "closed system." See Thermal Expansion and Closed Water Systems on page 14. The Temperature-Pressure Relief Valve is not intended for the constant relief of thermal expansion.

Temperature-Pressure Relief Valve leakage due to pressure build up in a closed system that does not have a thermal expansion tank installed is not covered under the limited warranty. Thermal expansion tanks must be installed on all closed water systems.

#### REPLACEMENT PARTS

Replacement parts may be ordered from the manufacturer, authorized service agencies or distributors. When ordering parts be sure to have the complete water heater Model Number, Serial Number and Series Number available. This information can be found on the rating label affixed to the water heater.

Refer to the parts list included with the water heater from the factory for more information or call the parts department or technical support phone number listed on the back cover of this manual for further assistance.

### FAULT AND ALERT CONDITIONS

#### FAULT CONDITIONS

When the control system declares a Fault condition it will display a Fault message on the control system's LCD with an exclamation "!" mark. The control system will lock out and disable heating operation until the condition is corrected. The water heater must be serviced by a qualified service agent before operation can be restored.

#### ALERT CONDITIONS

When the control system declares an Alert condition it will display an Alert message on the control system's LCD with a question "?" mark. The water heater will continue to operate during an Alert condition but the water heater must be serviced by a qualified service agent as soon as possible.

#### RESETTING CONTROL SYSTEM LOCK OUTS

To reset the control system from a lock out condition; turn the power supply off for approximately 20 seconds and then back on. Keep in mind; if the condition that caused the Fault has not been corrected, the control system will continue to lock out.

#### DIAGNOSTIC CHECKS

<b>! WARNING</b>	
<b>Electrical Shock Hazard</b>	
	<ul style="list-style-type: none"> <li>• Turn off power to the water heater before performing any service.</li> <li>• Label all wires prior to disconnecting when performing service. Wiring errors can cause improper and dangerous operation.</li> <li>• Verify proper operation after servicing.</li> <li>• Failure to follow these instructions can result in personal injury or death.</li> </ul>



The following section, Fault And Alert Messages on page 58, lists some of the messages the control system will display on the LCD when there are operational problems. This is not a complete list. Along with each of the Fault and Alert messages described there will be a list of possible causes and things to check and repair.

Only qualified service agents, as defined in Qualifications on page 6, using appropriate test equipment, should perform any service procedures on the water heater.

**NOTE:** If you are not qualified and licensed or certified as required by the authority having jurisdiction to perform a given task do not attempt to perform any of the diagnostic or service procedures described in the following section.

If you do not understand the instructions in the following section do not attempt to perform any procedures.





Call the technical support phone number listed on the back cover of this manual for further technical assistance or to locate a qualified service agent in your area.

<b>! WARNING</b>	
<b>Jumping out control circuits or components can result in property damage, personal injury or death.</b>	
<ul style="list-style-type: none"> <li>• Service should only be performed by a qualified service agent using proper test equipment.</li> <li>• Altering the water heater controls and/or wiring in any way could result in permanent damage to the controls or water heater and is not covered under the limited warranty.</li> <li>• Altering the water heater controls and/or wiring in any way could result in altering the ignition sequence allowing gas to flow to the main burner before the hot surface igniter is at ignition temperature causing delayed ignition which can cause a fire or explosion.</li> </ul>	
	<p>Any bypass or alteration of the water heater controls and/or wiring will result in voiding the appliance warranty.</p> 



**FAULT AND ALERT MESSAGES**

Call the technical support phone number listed on the back cover for further technical assistance or to locate a qualified service agent in your area.

POSSIBLE CAUSES - CHECK/REPAIR	DISPLAYED FAULT/ALERT MESSAGE
<ul style="list-style-type: none"> <li>The water heater's control system is polarity sensitive and will lock out and disable heating operation if the polarity of the power supply is reversed. The control system will display the "AC Reversed" Fault message on the LCD in this condition. See Power Supply Connections on page 39 for instructions on how to properly connect the power supply.</li> </ul> <p><b>NOTE:</b> Electronic flame sensing requires correct power supply polarity AND a proper earth ground to the water heater and the Main Burner. The control system does not verify earth ground but this should be checked first if ignition failure occurs. See the Ignition Failure Fault message information below.</p>	<div style="border: 1px solid black; padding: 10px;"> <p style="text-align: center;"><b>AC Reversed</b></p> <p style="text-align: center; font-size: small;">Fault occurred 2 mins ago</p> <div style="display: flex; justify-content: space-between;"> <div style="width: 60%;"> <p><b>!</b></p> <p>Power supply to water heater has reversed polarity.</p> <p>Call a service professional: Your Company Name Here (press [DOWN] for more....)</p> </div> <div style="width: 30%; text-align: center;">  </div> </div> <div style="display: flex; justify-content: space-around; margin-top: 5px;"> <span>BACK</span> <span>ADVANCED</span> </div> </div>
<ul style="list-style-type: none"> <li>The control system has failed to ignite the Main Burner.</li> <li>Water heater is not properly grounded, loose or open ground wire to the Main Burner - see Power Supply Connections on page 39.</li> <li>Dirty/corroded flame sensor, clean flame sensor with fine steel wool (replace if damaged) - see Figure 2 on page 7.</li> <li>Loose or open wiring to the flame sensor.</li> <li>Loose or open wiring to the 24 VAC Gas Valve.</li> <li>24 VAC Gas Valve control knob in the "off" position - see Figure 56 on page 51 and Figure 57 on page 52.</li> <li>Supply gas turned off, low gas volume - see page 37.</li> <li>Intake air and/or vent piping is restricted or improperly installed - see Venting Installation on page 21.</li> <li>Low or no manifold gas pressure to the Main Burner - see Initial Start Up on page 50.</li> </ul>	<div style="border: 1px solid black; padding: 10px;"> <p style="text-align: center;"><b>Ignition Failure</b></p> <p style="text-align: center; font-size: small;">Fault occurred 2 mins ago</p> <div style="display: flex; justify-content: space-between;"> <div style="width: 60%;"> <p><b>!</b></p> <p>The water heater has failed to ignite the burner.</p> <p>Call a service professional: Your Company Name Here (press [DOWN] for more....)</p> </div> <div style="width: 30%; text-align: center;">  </div> </div> <div style="display: flex; justify-content: space-around; margin-top: 5px;"> <span>BACK</span> <span>ADVANCED</span> </div> </div>
<ul style="list-style-type: none"> <li>The control system has detected the Low Gas Pressure Switch contacts are open.</li> <li>Loose or open wiring to the Low Gas Pressure Switch - see Figure 3 on page 8 for location.</li> <li>Supply gas pressure is below the required minimum pressure - see Table 4 on page 13.</li> <li>Supply gas is turned off at the Main Shutoff Valve.</li> <li>Supply gas pressure is dropping when other gas fired appliances on a common supply gas line are operating.</li> <li>Low volume of supply gas - see Supply Gas Line Installation on page 37 and the requirements for the Supply Gas Line on page 13 and Supply Gas Regulator on page 13.</li> </ul>	<div style="border: 1px solid black; padding: 10px;"> <p style="text-align: center;"><b>Low Gas Pressure</b></p> <p style="text-align: center; font-size: small;">Fault occurred 2 mins ago</p> <div style="display: flex; justify-content: space-between;"> <div style="width: 60%;"> <p><b>!</b></p> <p>The supply gas pressure to the water heater is low.</p> <p>Call a service professional: Your Company Name Here (press [DOWN] for more....)</p> </div> <div style="width: 30%; text-align: center;">  </div> </div> <div style="display: flex; justify-content: space-around; margin-top: 5px;"> <span>BACK</span> <span>ADVANCED</span> </div> </div>
<ul style="list-style-type: none"> <li>The control system has detected low current (AC amps) from the Hot Surface Igniter. The control system monitors igniter current and will declare this Fault condition if the current is not at or above the programmed minimum requirement - see the Sequence Of Operation on page 54 for minimum igniter amp requirements.</li> <li>Loose or open wiring to the Hot Surface Igniter - see Figure 2 on page 7 for igniter location.</li> <li>Damaged, worn or open circuit Hot Surface Igniter.</li> </ul> <p><b>NOTE:</b> Hot surface igniters are wearing parts. Wear is directly related to heating cycle count. Heating cycle count can be viewed in the Heater Information menu - see Heater Information on page 47. Increasing the Differential setting reduces heating cycle count - see Operating Set Point And Differential Adjustment on page 45.</p>	<div style="border: 1px solid black; padding: 10px;"> <p style="text-align: center;"><b>Low Igniter Current</b></p> <p style="text-align: center; font-size: small;">Fault occurred 2 mins ago</p> <div style="display: flex; justify-content: space-between;"> <div style="width: 60%;"> <p><b>!</b></p> <p>Igniter current is low.</p> <p>Call a service professional: Your Company Name Here (press [DOWN] for more....)</p> </div> <div style="width: 30%; text-align: center;">  </div> </div> <div style="display: flex; justify-content: space-around; margin-top: 5px;"> <span>BACK</span> <span>ADVANCED</span> </div> </div>
<ul style="list-style-type: none"> <li>The control system has detected the Blocked Exhaust Switch contacts are open.</li> <li>The condensate drain is blocked filling the exhaust elbow with water - clear the condensate drain - see Figure 9 on page 16.</li> <li>Loose or open wiring to the Blocked Exhaust Switch - see Figure 3 on page 8 for switch location.</li> <li>Restricted/blocked vent piping - condensate trapped in low point.</li> <li>Excessive equivalent pipe length, exceeded the maximum number of 90° elbows or wrong pipe size used in the vent piping system - see Venting Requirements on page 22.</li> <li>Excessive wind outdoors pressurizing the vent system piping.</li> <li>Excessive negative air pressure in the installed space.</li> </ul>	<div style="border: 1px solid black; padding: 10px;"> <p style="text-align: center;"><b>Blocked Exhaust</b></p> <p style="text-align: center; font-size: small;">Fault occurred 2 mins ago</p> <div style="display: flex; justify-content: space-between;"> <div style="width: 60%;"> <p><b>!</b></p> <p>The exhaust is blocked or restricted. Ensure condensate hose is draining.</p> <p>Call a service professional: Your Company Name Here (press [DOWN] for more....)</p> </div> <div style="width: 30%; text-align: center;">  </div> </div> <div style="display: flex; justify-content: space-around; margin-top: 5px;"> <span>BACK</span> <span>ADVANCED</span> </div> </div>



## FAULT AND ALERT MESSAGES (CONT)

Call the technical support phone number listed on the back cover for further technical assistance or to locate a qualified service agent in your area.

POSSIBLE CAUSES - CHECK/REPAIR	DISPLAYED FAULT/ALERT MESSAGE
<ul style="list-style-type: none"> <li>The control system has detected the Blower Prover Switch contacts are closed when they should be open at the beginning of a heating cycle - see the Sequence Of Operation on page 54.</li> <li>Pinched/shorted Blower Prover Switch wiring - see Figure 3 on page 8 for switch location.</li> <li>Jumper wire connected to the Blower Prover Switch - remove jumper wire. Jumper wires must never be used, read all Warnings on page 57.</li> <li>Excessive wind outdoors pressurizing the vent system piping.</li> <li>Excessive negative air pressure in the installed space.</li> </ul>	<div style="border: 1px solid black; padding: 10px;"> <p style="text-align: center;"><b>Blower Prover Failure</b></p> <p style="text-align: center;"><small>Fault occurred 2 mins ago</small></p> <p> The blower prover switch is closed out of sequence.</p> <p>Call a service professional: Your Company Name Here (press [DOWN] for more....)</p> <p style="text-align: right;">▲ ▨ ▼</p> <p style="text-align: center;">BACK    ADVANCED</p> </div>
<ul style="list-style-type: none"> <li>The control system has detected the Blower Prover Switch contacts are remaining open after the control system has energized the Combustion Blower - see the Sequence Of Operation on page 54.</li> <li>Loose or open wiring to the Blower Prover Switch - see Figure 3 on page 8 for switch location.</li> <li>Blower Prover Switch air sensing tube disconnected, kinked, filed with condensate, damaged or leaking - repair or replace tube.</li> <li>Combustion Blower is not running when energized.</li> <li>Loose or open wiring to Combustion Blower.</li> <li>Loose, open, incorrect wiring to the VFD on SUF 130 400 and SUF 130 500 models - see Figure 3 on page 8 and the wiring diagram on page 65.</li> </ul>	<div style="border: 1px solid black; padding: 10px;"> <p style="text-align: center;"><b>Blower Prover Open</b></p> <p style="text-align: center;"><small>Fault occurred 2 mins ago</small></p> <p> The blower prover switch remains open after the blower has been energized.</p> <p>Call a service professional: Your Company Name Here (press [DOWN] for more....)</p> <p style="text-align: right;">▲ ▨ ▼</p> <p style="text-align: center;">BACK    ADVANCED</p> </div>
<ul style="list-style-type: none"> <li>The control system has detected the Blocked Intake Air Switch contacts are open.</li> <li>Loose or open wiring to the Blocked Intake Air Switch - see Figure 3 on page 8 for switch location.</li> <li>Excessive equivalent pipe length, exceeded the maximum number of 90° elbows or wrong pipe size used in the intake air piping system - see Venting Requirements on page 22.</li> <li>Balance plate and/or intake air screen was not removed prior to connecting the intake air piping to the water heater and is clogged/ blocked with debris - see Figure 17 on page 24.</li> <li>Excessive negative air pressure in the installed space.</li> </ul>	<div style="border: 1px solid black; padding: 10px;"> <p style="text-align: center;"><b>Blocked Air Intake</b></p> <p style="text-align: center;"><small>Fault occurred 2 mins ago</small></p> <p> The combustion air intake is restricted.</p> <p>Call a service professional: Your Company Name Here (press [DOWN] for more....)</p> <p style="text-align: right;">▲ ▨ ▼</p> <p style="text-align: center;">BACK    ADVANCED</p> </div>
<ul style="list-style-type: none"> <li>The control system has detected the ECO (energy cut out) Switch contacts are open.</li> <li>The ECO switch is a normally closed switch that opens on a temperature rise to prevent excessive water temperature in the storage tank. The ECO switch is inside the Upper Temperature Probe (two red wires) - see Figure 3 on page 8 for Upper Probe location.</li> <li>Loose or open wiring to the ECO switch in the Upper Temperature Probe - two red wires.</li> <li>Improper water system piping and/or excessively high return (recirculation) loop water temperature - see the Water Piping Diagrams beginning on page 67.</li> </ul>	<div style="border: 1px solid black; padding: 10px;"> <p style="text-align: center;"><b>Energy Cut Out (ECO)</b></p> <p style="text-align: center;"><small>Fault occurred 2 mins ago</small></p> <p> Tank temperature is excessive. The water heater has been disabled.</p> <p>Call a service professional: Your Company Name Here (press [DOWN] for more....)</p> <p style="text-align: right;">▲ ▨ ▼</p> <p style="text-align: center;">BACK    ADVANCED</p> </div>
<ul style="list-style-type: none"> <li>The control system has not detected any voltage from the powered anode rods - see Figure 3 on page 8 for location.</li> <li>No water in the storage tank.</li> <li>Loose or open wiring connections to the powered anode rods - see Figure 3 on page 8 for location.</li> <li>Powered anode rod wiring shorted to ground.</li> <li>The water heater is not properly grounded - see Power Supply Connections on page 39.</li> <li>Loose or open ground wires.</li> <li>Top fitting (3/4 inch bushing) of the powered anode rods were saturated with water during installation - with power to the water heater turned off, carefully remove anode rods and dry out bushing(s).</li> </ul>	<div style="border: 1px solid black; padding: 10px;"> <p style="text-align: center;"><small>Alert:</small></p> <p style="text-align: center;"><b>No Anode Voltage</b></p> <p style="text-align: center;"><small>Alert occurred 2 mins ago</small></p> <p> No voltage detected from Powered Anode(s).</p> <p>Call a service professional: Your Company Name Here (press [DOWN] for more....)</p> <p style="text-align: right;">▲ ▨ ▼</p> <p style="text-align: center;">BACK    ADVANCED</p> </div>

# MAINTENANCE

## GENERAL

Keep appliance area clear and free from combustible materials, gasoline and other flammable vapors and liquids. See Locating The Water Heater on page 11.

Water heater maintenance includes periodic tank flushing and cleaning, and removal of lime scale. The water heater should be inspected and adjusted to maintain proper combustion. See Initial Start Up on page 50. A periodic inspection of the venting system should be made. Where used, water circulating pump(s) should be oiled according to the pump manufacturers recommendations.

## PRECAUTIONS

### ⚠ CAUTION

**Do not operate the water heater if it has been exposed to or exhibits the following:**

- Flooding at or above the level of the burner or controls.
- External damage.
- Firing without water.
- Sooting.

Do not operate the water heater until all corrective steps have been made by a qualified service agent.

Never operate the water heater without first being certain it is filled with water and a properly sized and rated Temperature-Pressure Relief Valve is installed in the relief valve opening on the water heater. See Temperature-Pressure Relief Valve on page 15.

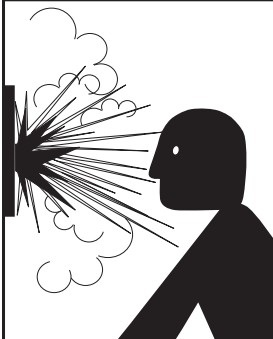

### ⚠ WARNING

#### Explosion Hazard

- Overheated water can cause water tank explosion.
- Properly sized temperature and pressure relief valve must be installed in the opening provided.

Should overheating occur or the gas supply fail to shut off, turn off the Main Gas Shutoff valve. See Figure 52 on page 37.

Water heater maintenance includes periodic tank flushing and cleaning, and removal of lime scale. The water heater should be inspected and adjusted to maintain proper combustion. Refer to the following table. A periodic inspection of the venting system should be made. Where used, the water circulating pump should be oiled according to the pump manufacturer's recommendations.

## MAINTENANCE SCHEDULE

TABLE 14

COMPONENT	OPERATION	INTERVAL	REQUIRED
Tank	Sediment Removal	Semi Annually	Flushing
Tank	Lime Scale Removal	Semi Annually	UN-LIME®
Anode Rods	Inspection Cleaning	Annually	Clean Scale Deposits
T&P Valve	Test Operation	Semi Annually	Test
Vent System	Inspection	Annually	Termination Screens Clean Reseal/Repair

## DRAINING AND FLUSHING

It is recommended that the water heater storage tank be drained and flushed every 6 months to reduce sediment buildup. The water heater should be drained if being shut down during freezing temperatures. See Features And Components on page 7 for the location of the water heater components described below.

### ⚠ DANGER

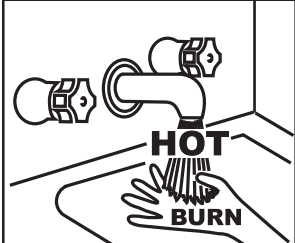

- Burn hazard.
- Hot water discharge.
- Keep hands clear of drain valve discharge.

### To drain the water heater storage tank:

1. Turn off the electrical supply to the water heater.
2. Turn off the gas supply at the Main Gas Shutoff Valve if the water heater is going to be shut down for an extended period.
3. Ensure the cold water inlet valve is open.
4. Open a nearby hot water faucet and let the water run until the water is no longer hot.
5. Connect a hose to the water heater drain valve and terminate it to an adequate drain.
6. Close the cold water inlet valve.
7. Open the water heater drain valve and allow all the water to drain from the storage tank.
8. Close the water heater drain valve when all water in the storage tank has drained.
9. Close the hot water faucet opened in Step 4.
10. If the water heater is going to be shut down for an extended period, the drain valve should be left open.

### To Flush the tank perform the following steps:

1. Turn off the electrical supply to the water heater.
2. Ensure the cold water inlet valve is open.
3. Open a nearby hot water faucet and let the water run until the water is no longer hot. Then close the hot water faucet.
4. Connect a hose to the drain valve and terminate it to an adequate drain.

5. Ensure the drain hose is secured before and during the entire flushing procedure. Flushing is performed with system water pressure applied to the water heater.
6. Open the water heater drain valve to flush the storage tank.
7. Flush the water heater storage tank to remove sediment and allow the water to flow until it runs clean.
8. Close the water heater drain valve when flushing is completed.
9. Remove the drain hose.
10. Fill the water heater - see Filling The Water Heater on page 50.
11. Turn on the electrical supply to place the water heater back in operation. See Initial Start Up on page 50.
12. Allow the water heater to complete several heating cycles to ensure it is operating properly.

## FILLING THE WATER HEATER

See Filling The Water Heater on page 50.

## SEDIMENT REMOVAL

Waterborne impurities consist of the particles of soil and sand which settle out and form a layer of sediment on the bottom of the tank.

For convenience, sediment removal and lime scale removal should be performed at the same time.

## LIME SCALE REMOVAL

When water is heated dissolved minerals in the water such as calcium and magnesium carbonate (lime scale) become less soluble. As the water temperature rises these minerals will precipitate or "fall out" of solution.

The amount of lime scale released from water is in direct proportion to water temperature and usage. The higher the water temperature or water usage, the more lime deposits are dropped out of the water.

Water hardness also affects lime scale accumulation. With the temperature and usage being the same, hard water will release more lime scale than softer water.

Lime scale reduces heating efficiency as it accumulates inside a water heater. Heating transfer surfaces become coated with lime scale deposits which increases fuel costs to operate the water heater. Lime scale deposits can also cause rumbling and pounding noises as air molecules trapped in the lime scale escape when heated. Lime scale accumulation also reduces the life span of water heaters. For these reasons a regular schedule for deliming should be set up.

The depth of lime accumulation in the bottom of the water heater should be measured periodically. Inspect by removing the cleanout cover once every 6 months at first. Deliming maintenance should then be performed based on the time it takes for 1 inch (2.5 cm) of lime to accumulate in the bottom of the water heater.

Sediment and lime scale removal may be accomplished manually through the cleanout opening furnished on the water heater, see Figure 59.

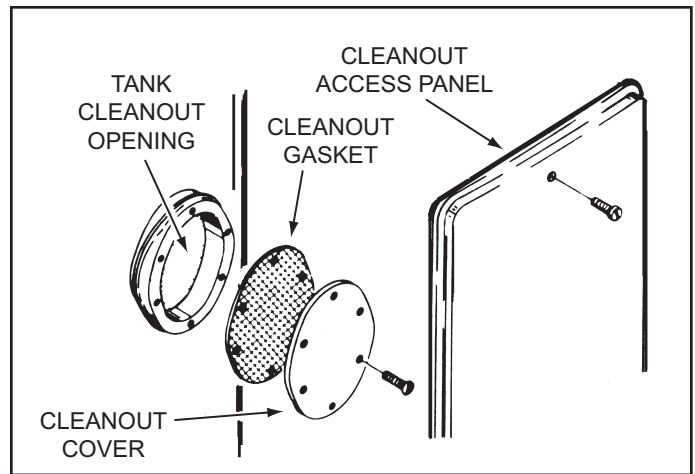

Figure 59

## MANUAL LIME SCALE REMOVAL

**NOTE:** Contact your local distributor or call the parts department phone number on the back cover of this manual to order a new cleanout gasket. Have the new gasket available before removing the cleanout cover.

The cleanout opening is shown in Figure 59. To remove lime scale manually through the cleanout opening proceed as follows:

1. Turn off the electrical supply to the water heater.
2. The water heater must be drained, see Draining And Flushing on page 60, follow the instructions on how to drain the water heater.
3. Remove outer cleanout access plate from lower side of the water heater jacket.
4. Remove the cleanout cover from cleanout opening.
5. Remove lime, scale and/or sediment using care not to damage the glass-lining.
6. Install a new cleanout gasket if required.
7. Reinstall the cleanout cover. Be sure to draw plate up tight by tightening screws securely.
8. Close the water heater drain valve.
9. Fill the water heater - see Filling The Water Heater on page 50.
10. Turn on the electrical supply to place the water heater back in operation. See Initial Start Up on page 50.
11. Allow the water heater to complete several heating cycles to ensure it is operating properly.
12. Check for water leakage.
13. Reinstall the cleanout access plate.

## CHEMICAL LIME SCALE REMOVAL

To dissolve and remove more stubborn lime scale deposits, UN-LIME® Professional Delimer should be used.

UN-LIME® Professional Delimer is an easy to handle patented food grade acid formulated specifically for lime scale removal from all types of water using equipment. Hydrochloric base acids must not be used to delime the water heaters covered in this manual.

Follow the instructions on the UN-LIME® to delime the water heater.

**NOTE:** Call the parts department phone number on the back cover of this manual to order UN-LIME® Professional Delimer. See TABLE 15 on page 62 for part numbers.

TABLE 15

UN-LIME® PROFESSIONAL DELIMER	
Part Number	Description
9005416105	4 - 1 gallon (case)
9005417105	1 - 5 gallon

**POWERED ANODE RODS**

To insure a long, trouble-free operating life, the water heaters covered in this manual are factory equipped with a powered anode system. The anode rods (2) are of a permanent design and do not need replacing unless damaged. Inspection and cleaning should be performed once a year.

**NOTE:** Follow the instructions to drain the water heater storage tank on page 60 first. Remove the powered anodes from the water heater by loosening the 3/4" NPT bushing that forms the top of the anodes. Do not disassemble the retaining nut and wire terminal from the top while installed in the water heater, the anode's electrode may fall inside the tank. Remove the entire anode rod from the water heater prior to inspection. Clean the anode rods with a soft cloth and reinstall. Follow the instructions for filling the water heater on page 50 when finished.

**DRAIN VALVE AND ACCESS PANELS**

The water heaters covered in this manual are equipped with a drain valve, see Features And Components on page 7 for location. The water heaters covered in this manual are also equipped with a cleanout opening for sediment and lime scale removal. See Figure 59 on page 61.

**TEMPERATURE-PRESSURE RELIEF VALVE TEST**

- Burn hazard.
- Hot water discharge.
- Keep clear of Temperature-Pressure Relief Valve discharge outlet.

It is recommended that the Temperature-Pressure Relief Valve should be checked to ensure that it is in operating condition every 6 months.

When checking the Temperature-Pressure Relief Valve operation, make sure that (1) no one is in front of or around the outlet of the Temperature-Pressure Relief Valve discharge line, and (2) that the water discharge will not cause any property damage, as the water may be extremely hot. Use care when operating valve as the valve may be hot.

To check the relief valve, lift the lever at the end of the valve several times, see Figure 60. The valve should seat properly and operate freely.

If after manually operating the valve, it fails to completely reset and continues to release water, immediately close the cold water inlet to the water heater and drain the water heater, see Draining And Flushing on page 60. Replace the Temperature-Pressure Relief Valve with a properly rated/sized new one, see Temperature-Pressure Relief Valve on page 15 for instructions on replacement.

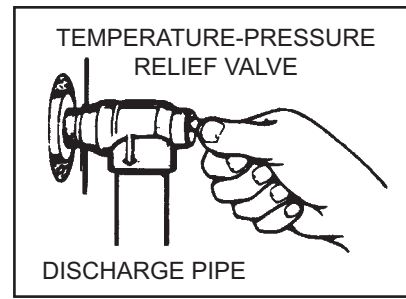

Figure 60

If the Temperature-Pressure Relief Valve on the water heater weeps or discharges periodically, this may be due to thermal expansion.

**NOTE:** Excessive water pressure is the most common cause of Temperature-Pressure Relief Valve leakage. Excessive water system pressure is most often caused by "thermal expansion" in a "closed system." See Thermal Expansion and Closed Water Systems on page 14. The Temperature-Pressure Relief Valve is not intended for the constant relief of thermal expansion.

Temperature-Pressure Relief Valve leakage due to pressure build up in a closed system that does not have a thermal expansion tank installed is not covered under the limited warranty. Thermal expansion tanks must be installed on all closed water systems.

**DO NOT PLUG THE TEMPERATURE-PRESSURE RELIEF VALVE OPENING. THIS CAN CAUSE PROPERTY DAMAGE, SERIOUS INJURY OR DEATH.**

! WARNING

Explosion Hazard

- Temperature-Pressure Relief Valve must comply with ANSI Z21.22- CSA 4.4 and ASME code.
- Properly sized temperature-pressure relief valve must be installed in opening provided.
- Can result in overheating and excessive tank pressure.
- Can cause serious injury or death.

**VENT SYSTEM**

Examine the vent system once a year. Points of inspection are as follows:

1. Check for obstructions and/or deterioration of the intake air and/or vent piping and the intake air and vent terminations. Replace immediately where needed.
2. The debris screens in the intake air and vent terminations should be cleaned of foreign material and soot. See Figure 22 on page 26.

**NOTE:** Do not reach inside the vent hood when the heater is in operation.

3. Check all vent system connections for leakage and repair or reseal as necessary.

# DIAGRAMS

## CCB - CENTRAL CONTROL BOARD LAYOUT

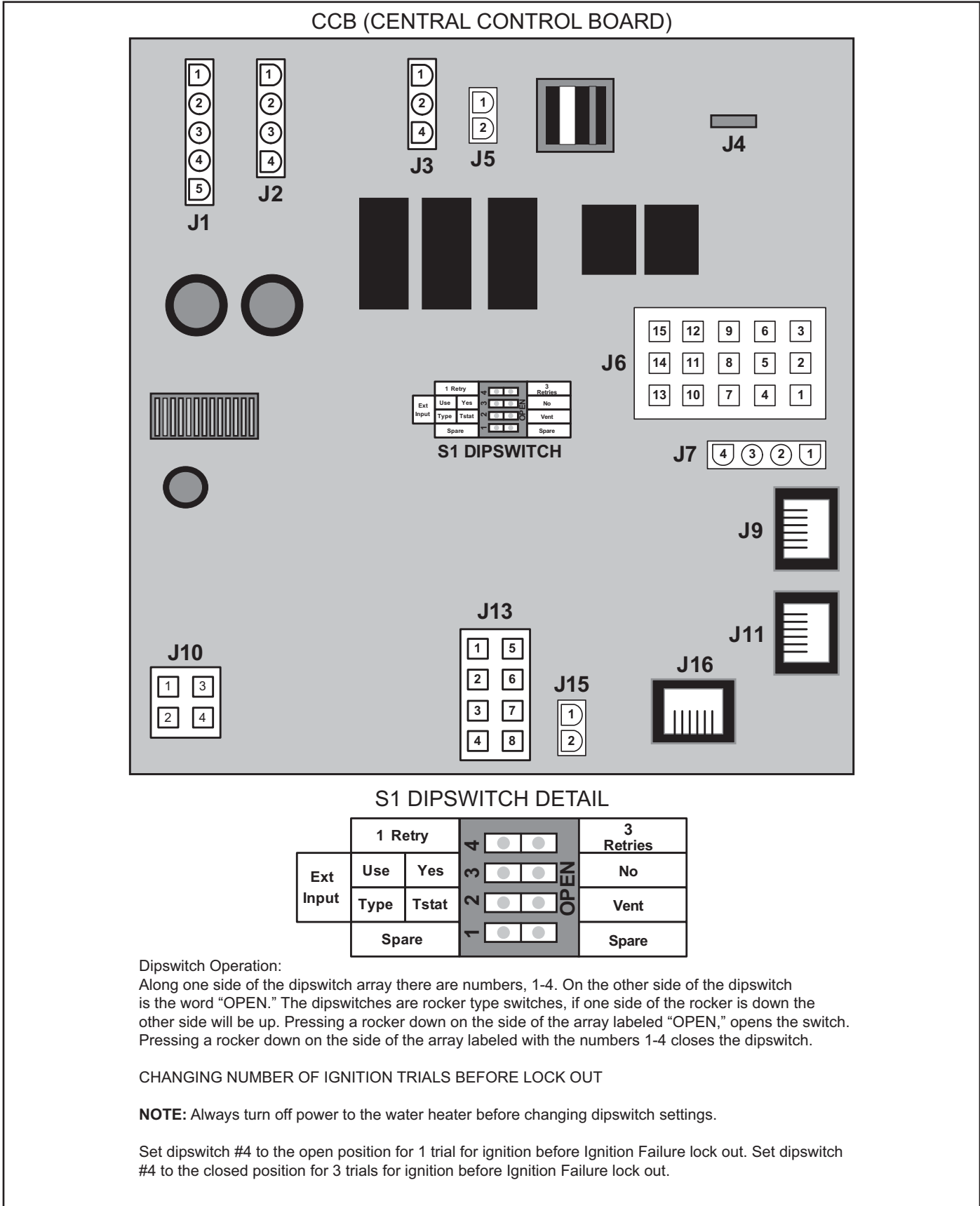

Figure 61



SUF 130 300 WIRING DIAGRAM

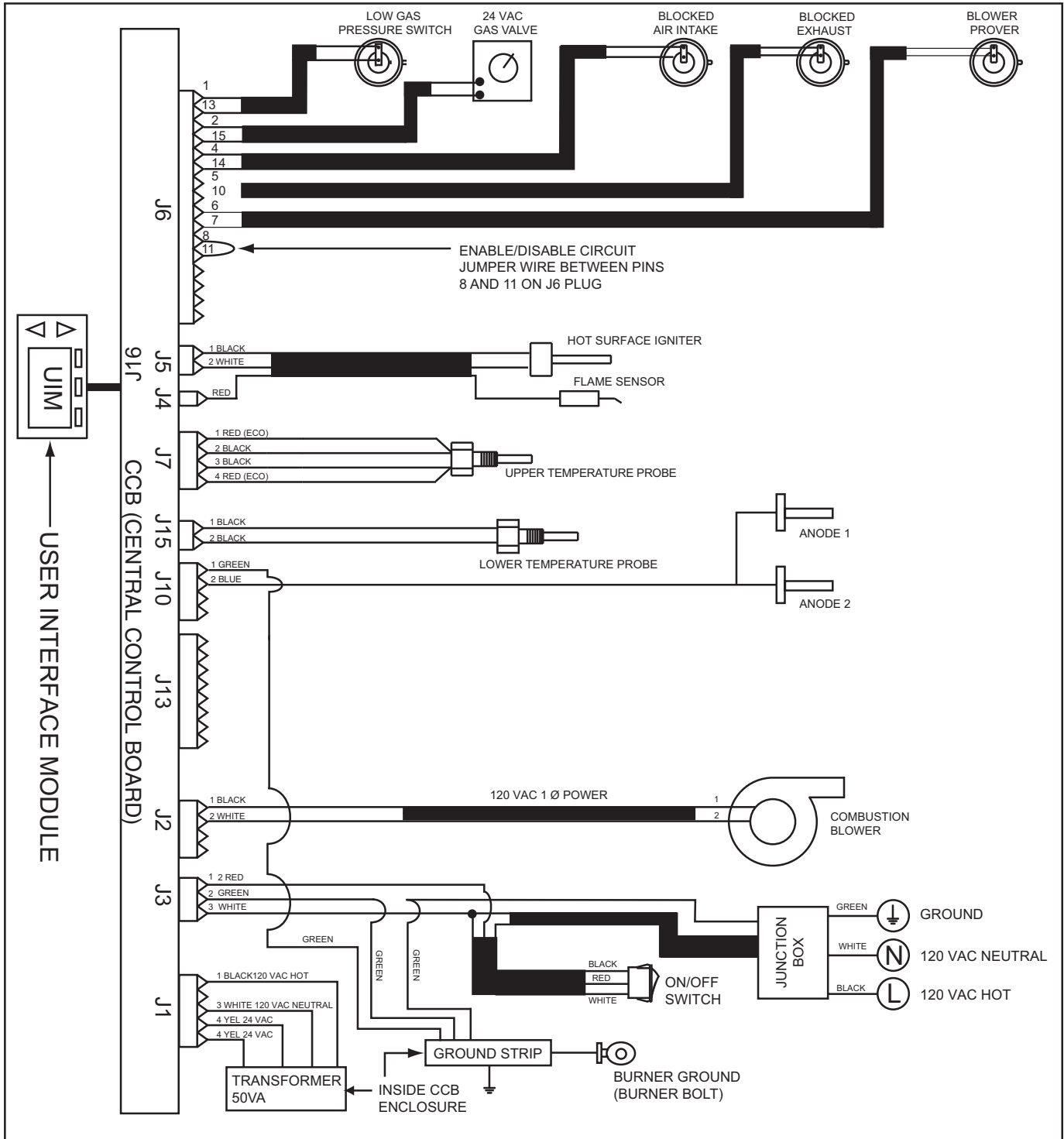

Figure 62

SUF 130 400, 500 WIRING DIAGRAM

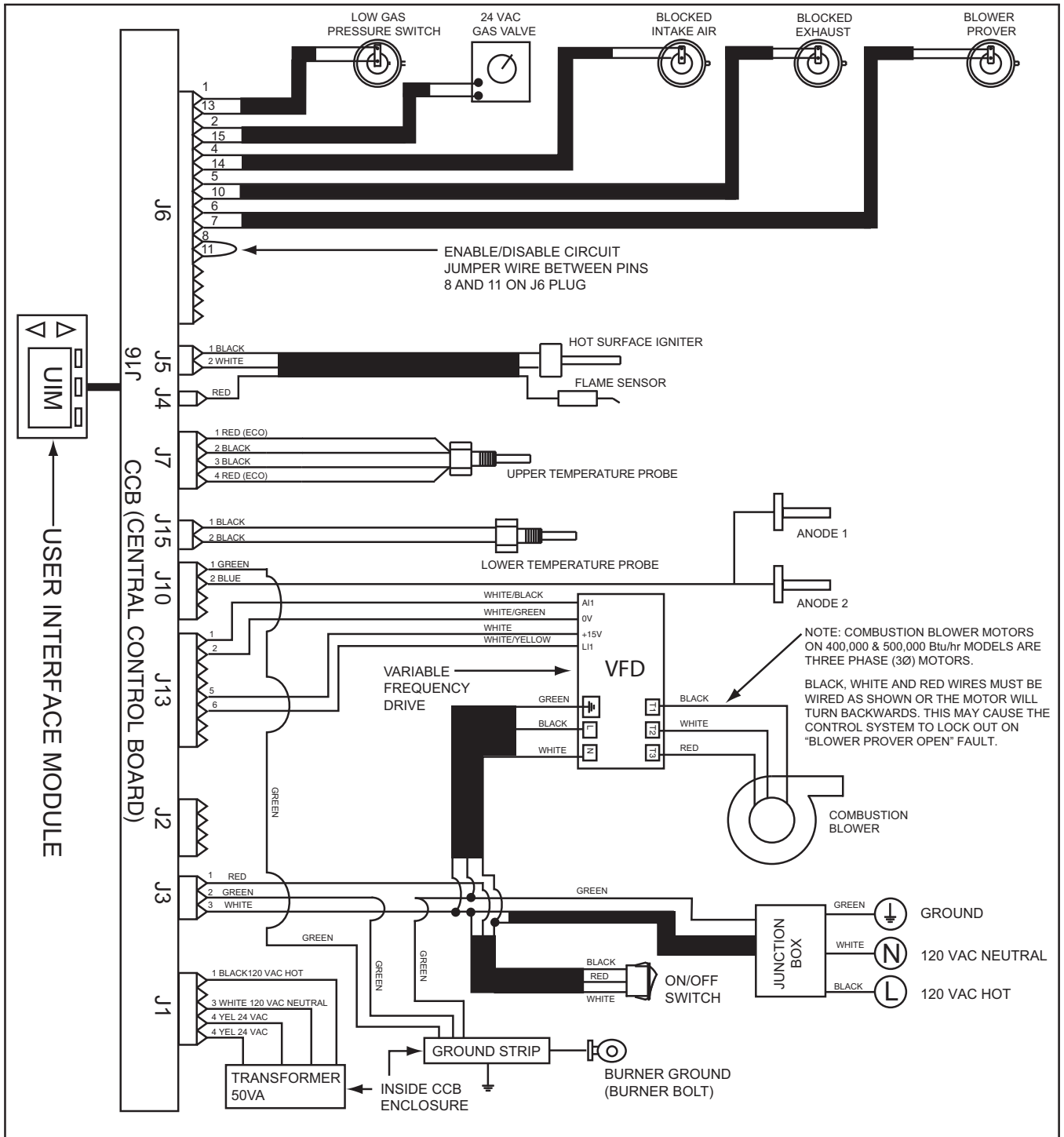

Figure 63

CIRCULATING PUMP WIRING DIAGRAM  
STORAGE TANK OR BUILDING RECIRCULATION

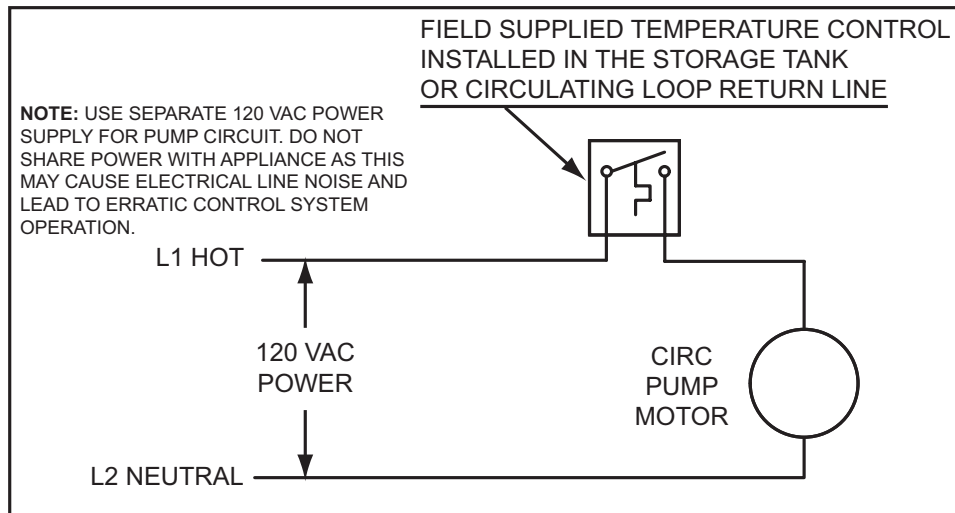

Figure 64

CIRCULATING PUMP WIRING DIAGRAM  
DISHWASHER LOOP WITH TOGGLE SWITCH

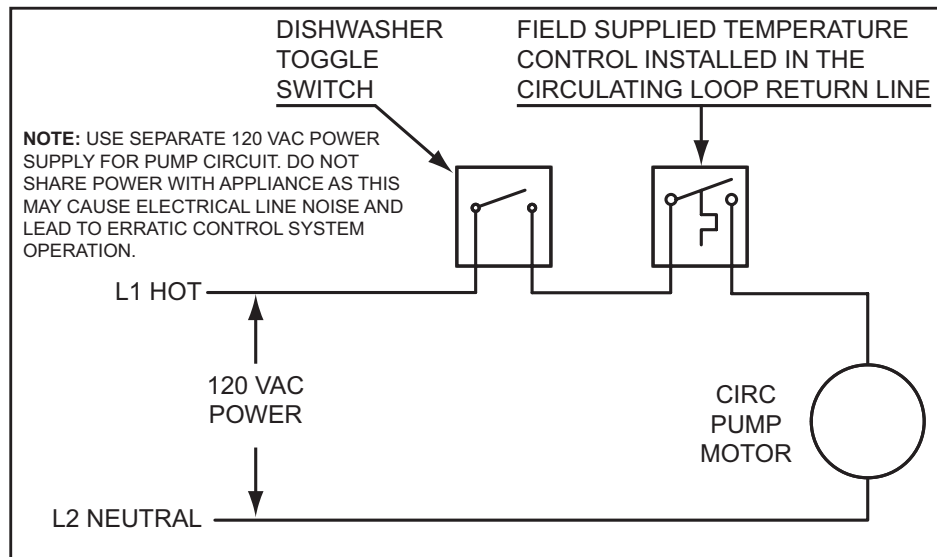
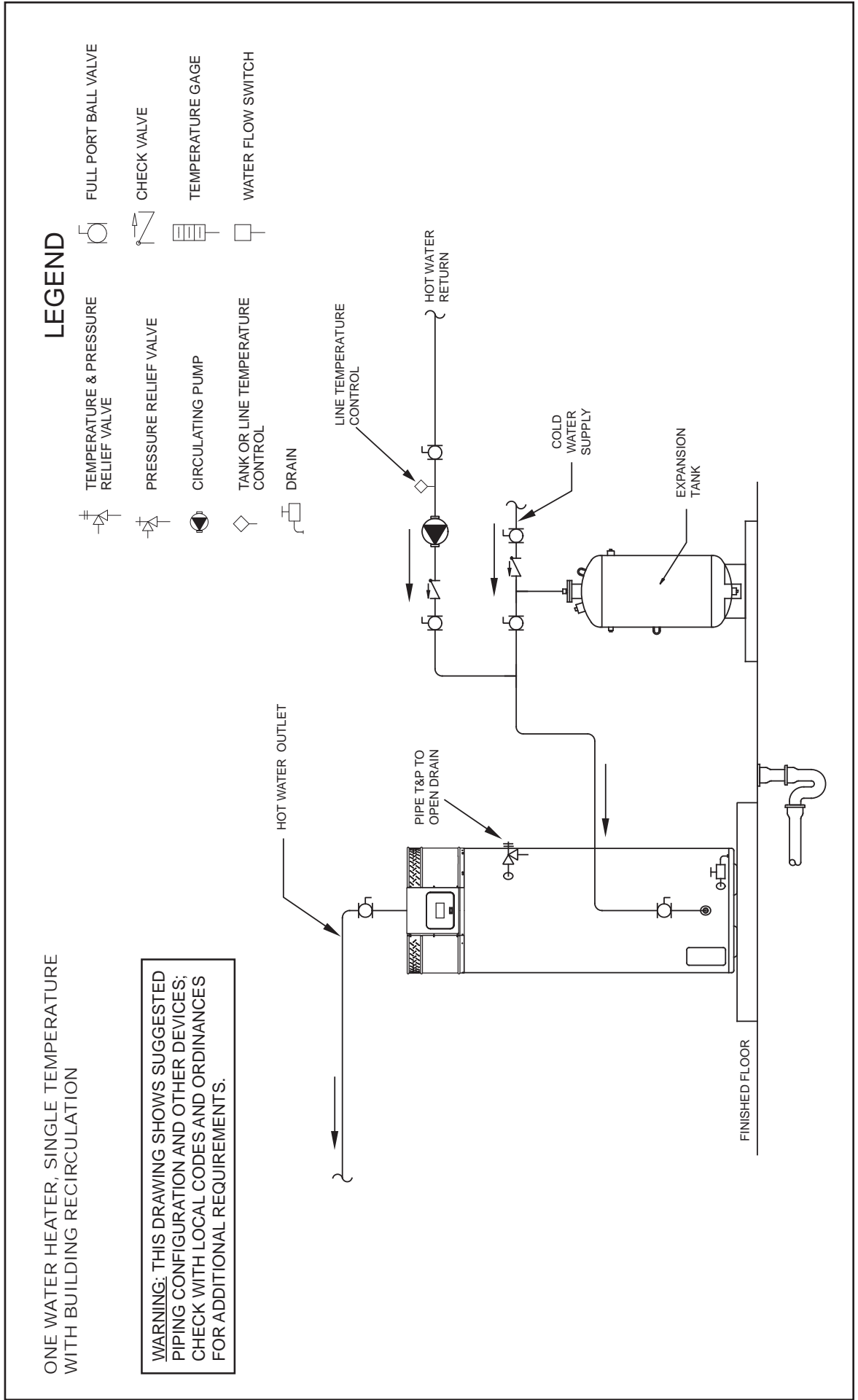

Figure 65

## WATER PIPING DIAGRAMS

Before installation of water piping review the following:

1. See Mixing Valves on page 14.
2. See Dishwashing Machines on page 14.
3. See Temperature-Pressure Relief Valve on page 15.
4. See Closed Systems and Thermal Expansion on page 14
5. See Water Line Connections on page 40.
6. If a pump is being installed between a water heater and storage tank or on a building recirculation loop wire according to Figure 64 on page 66.
7. If a pump is being installed in a recirculation loop between the water heater and a commercial dishwasher wire according to Figure 64 or Figure 65 on page 66.



## WATER PIPING DIAGRAMS

Before installation of water piping review the following:

1. See Mixing Valves on page 14.
2. See Dishwashing Machines on page 14.
3. See Temperature-Pressure Relief Valve on page 15.
4. See Closed Systems and Thermal Expansion on page 14
5. See Water Line Connections on page 40.
6. If a pump is being installed between a water heater and storage tank or on a building recirculation loop wire according to Figure 64 on page 66.
7. If a pump is being installed in a recirculation loop between the water heater and a commercial dishwasher wire according to Figure 64 or Figure 65 on page 66.

### ONE WATER HEATER, TWO TEMPERATURE WITH HIGH TEMPERATURE LOOP RECIRCULATION WITH BUILDING RECIRCULATION

**WARNING: THIS DRAWING SHOWS SUGGESTED PIPING CONFIGURATION AND OTHER DEVICES; CHECK WITH LOCAL CODES AND ORDINANCES FOR ADDITIONAL REQUIREMENTS.**

### LEGEND

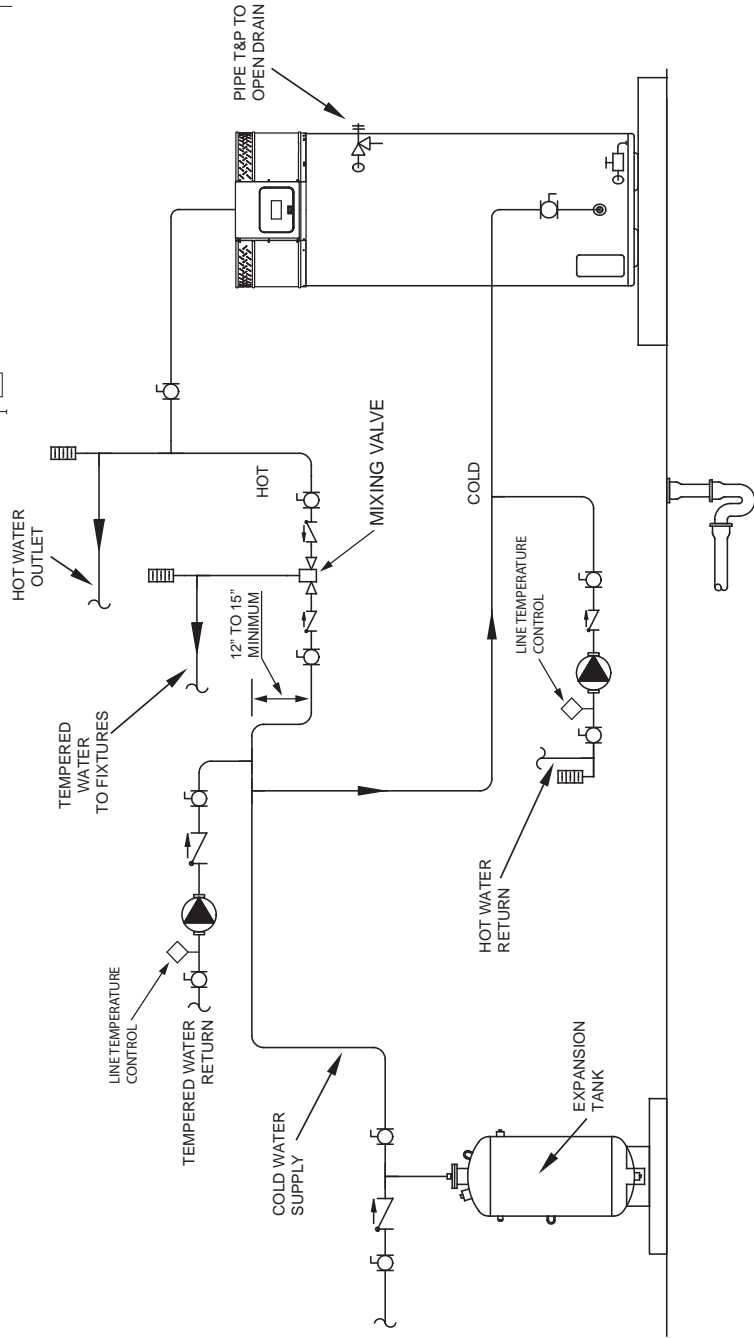
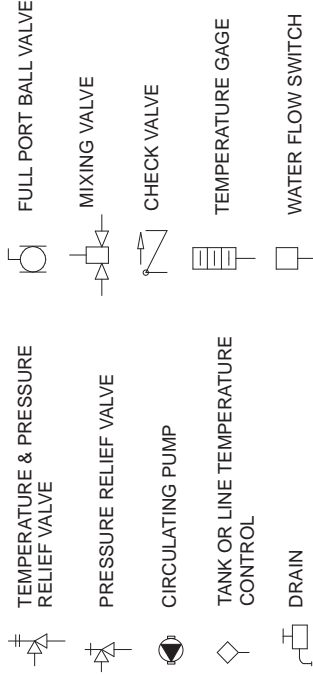



## WATER PIPING DIAGRAMS

Before installation of water piping review the following:

1. See Mixing Valves on page 14.
2. See Dishwashing Machines on page 14.
3. See Temperature-Pressure Relief Valve on page 15.
4. See Closed Systems and Thermal Expansion on page 14
5. See Water Line Connections on page 40.
6. If a pump is being installed between a water heater and storage tank or on a building recirculation loop wire according to Figure 64 on page 66.
7. If a pump is being installed in a recirculation loop between the water heater and a commercial dishwasher wire according to Figure 64 or Figure 65 on page 66.

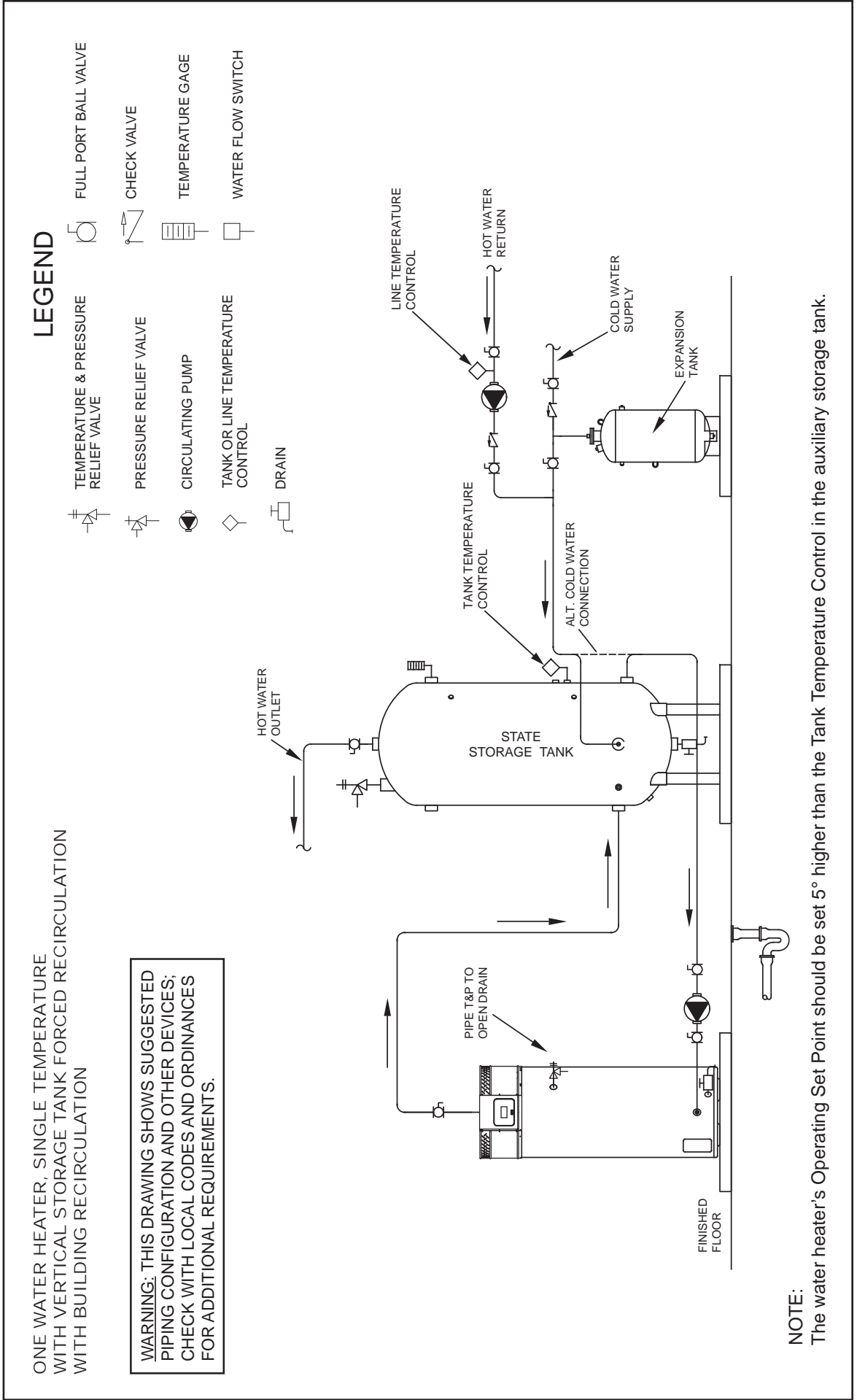

## WATER PIPING DIAGRAMS

Before installation of water piping review the following:

1. See Mixing Valves on page 14.
2. See Dishwashing Machines on page 14.
3. See Temperature-Pressure Relief Valve on page 15.
4. See Closed Systems and Thermal Expansion on page 14
5. See Water Line Connections on page 40.
6. If a pump is being installed between a water heater and storage tank or on a building recirculation loop wire according to Figure 64 on page 66.
7. If a pump is being installed in a recirculation loop between the water heater and a commercial dishwasher wire according to Figure 64 or Figure 65 on page 66.

### ONE WATER HEATER, SINGLE TEMPERATURE WITH HORIZONTAL STORAGE TANK FORCED RECIRCULATION WITH BUILDING RECIRCULATION

**WARNING: THIS DRAWING SHOWS SUGGESTED PIPING CONFIGURATION AND OTHER DEVICES; CHECK WITH LOCAL CODES AND ORDINANCES FOR ADDITIONAL REQUIREMENTS.**

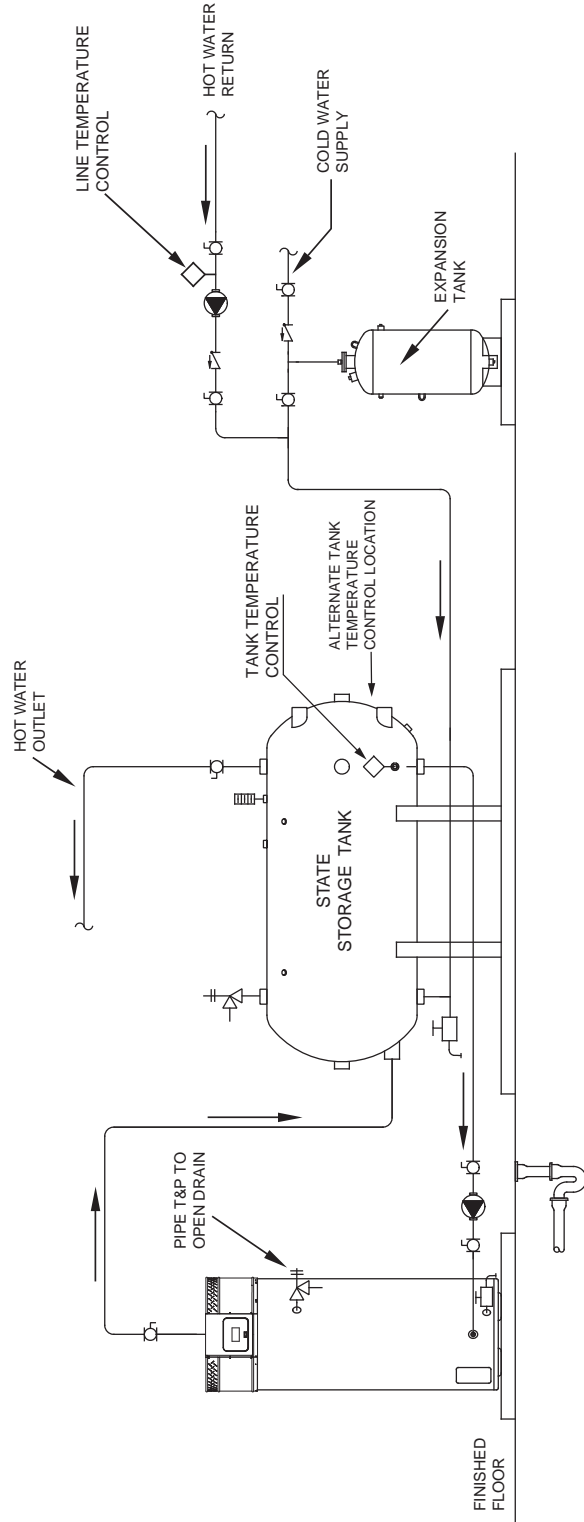
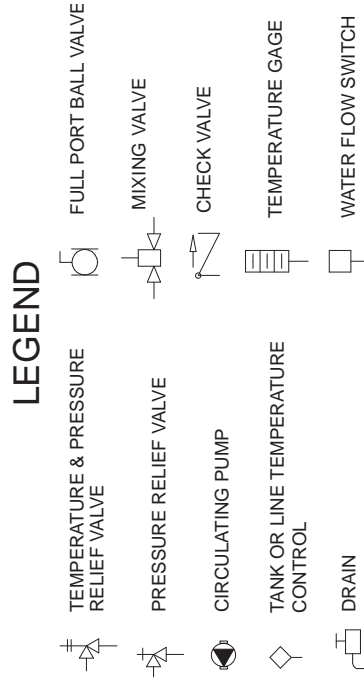

**NOTE:**  
The water heater's Operating Set Point should be set 5° higher than the Tank Temperature Control in the auxiliary storage tank.

## WATER PIPING DIAGRAMS

Before installation of water piping review the following:

1. See Mixing Valves on page 14.
2. See Dishwashing Machines on page 14.
3. See Temperature-Pressure Relief Valve on page 15.
4. See Closed Systems and Thermal Expansion on page 14
5. See Water Line Connections on page 40.
6. If a pump is being installed between a water heater and storage tank or on a building recirculation loop wire according to Figure 64 on page 66.
7. If a pump is being installed in a recirculation loop between the water heater and a commercial dishwasher wire according to Figure 64 or Figure 65 on page 66.

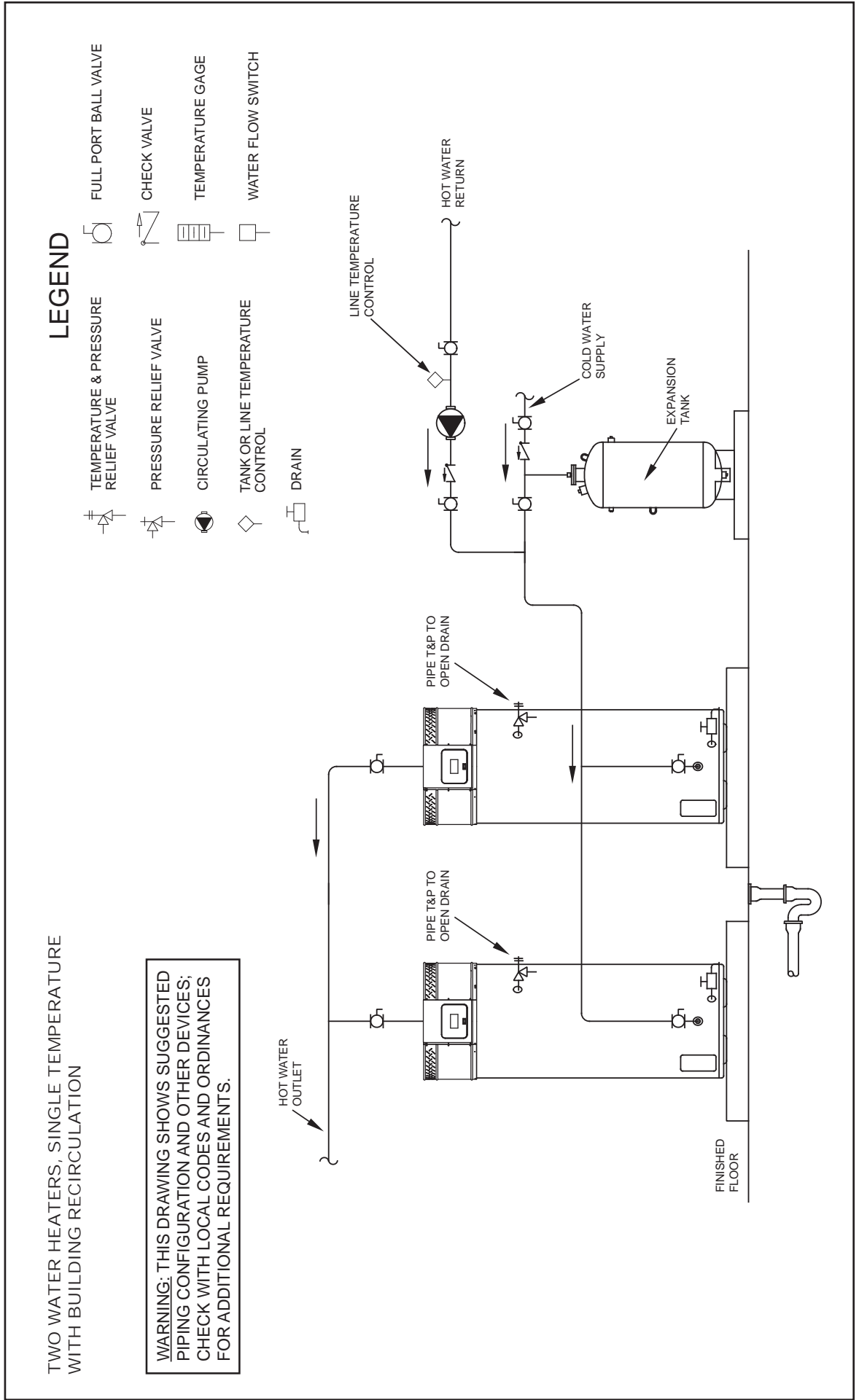

## WATER PIPING DIAGRAMS

Before installation of water piping review the following:

1. See Mixing Valves on page 14.
2. See Dishwashing Machines on page 14.
3. See Temperature-Pressure Relief Valve on page 15.
4. See Closed Systems and Thermal Expansion on page 14
5. See Water Line Connections on page 40.
6. If a pump is being installed between a water heater and storage tank or on a building recirculation loop wire according to Figure 64 on page 66.
7. If a pump is being installed in a recirculation loop between the water heater and a commercial dishwasher wire according to Figure 64 or Figure 65 on page 66.

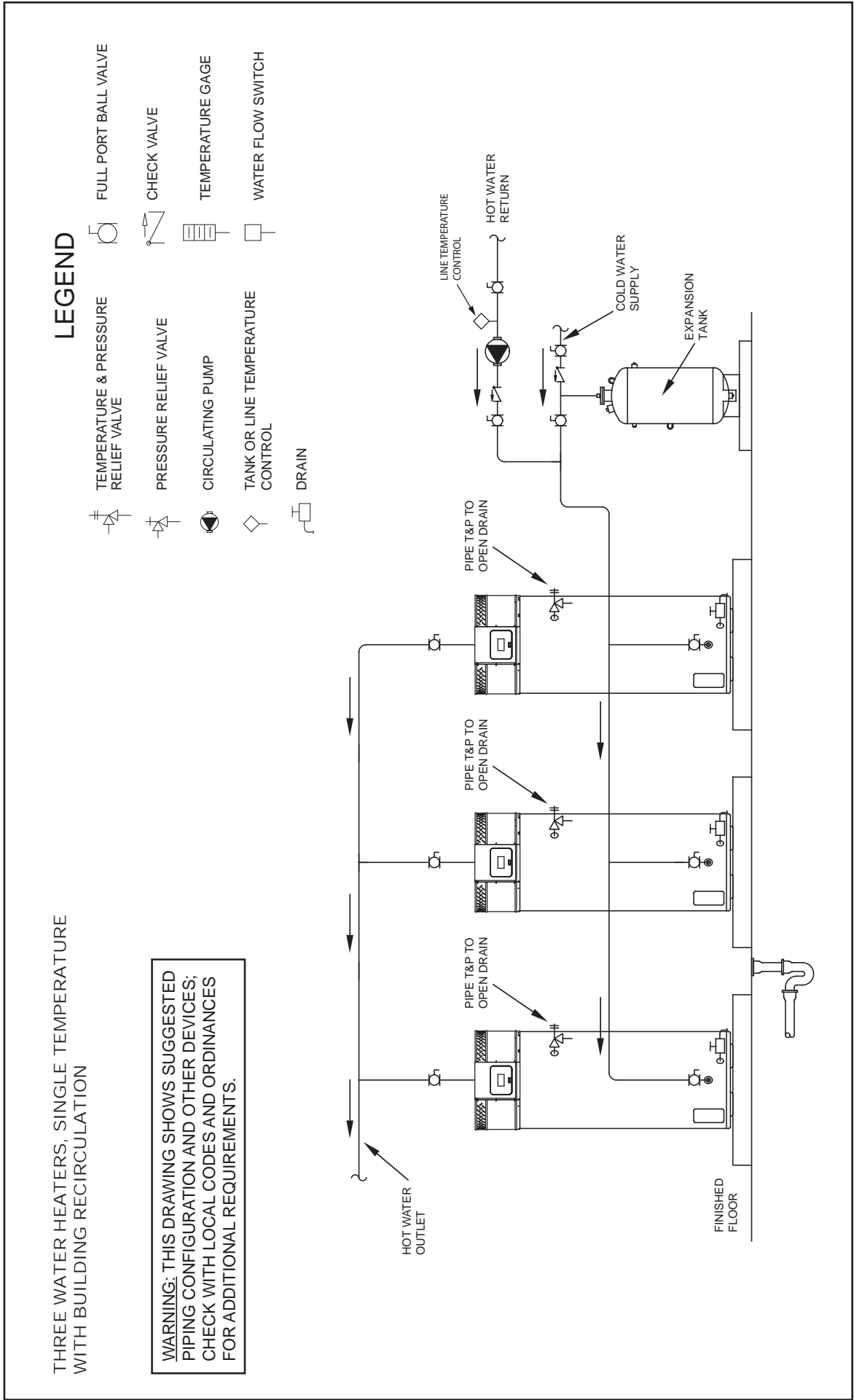

## WATER PIPING DIAGRAMS

Before installation of water piping review the following:

1. See Mixing Valves on page 14.
2. See Dishwashing Machines on page 14.
3. See Temperature-Pressure Relief Valve on page 15.
4. See Closed Systems and Thermal Expansion on page 14
5. See Water Line Connections on page 40.
6. If a pump is being installed between a water heater and storage tank or on a building recirculation loop wire according to Figure 64 on page 66.
7. If a pump is being installed in a recirculation loop between the water heater and a commercial dishwasher wire according to Figure 64 or Figure 65 on page 66.

### FOUR WATER HEATERS, SINGLE TEMPERATURE WITH BUILDING RECIRCULATION

**WARNING: THIS DRAWING SHOWS SUGGESTED PIPING CONFIGURATION AND OTHER DEVICES; CHECK WITH LOCAL CODES AND ORDINANCES FOR ADDITIONAL REQUIREMENTS.**

### LEGEND

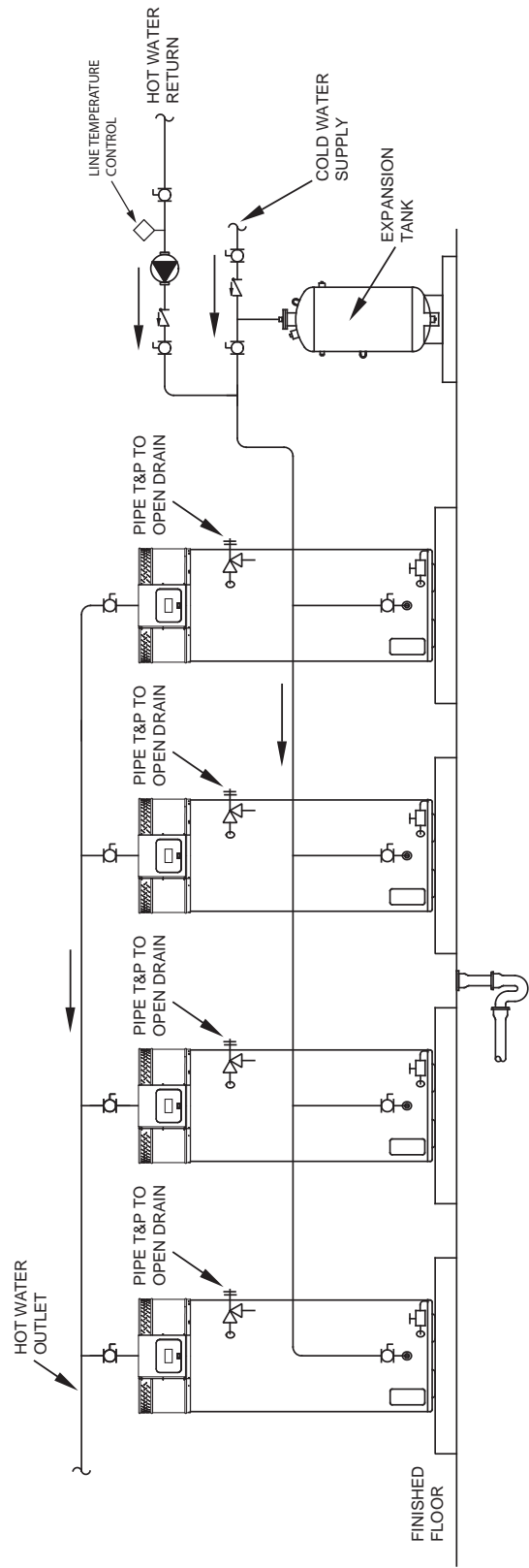
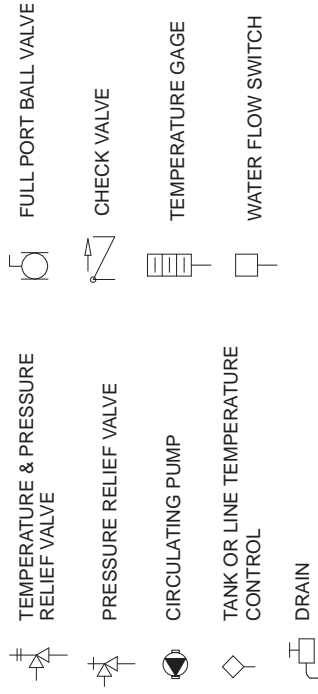



## LIMITED WARRANTY

State Water Heaters, the warrantor, extends the following LIMITED WARRANTY to the owner of this water heater.

### 1. THE TANK

If the glass-lined tank in this water heater shall prove upon examination by the warrantor to have leaked due to natural corrosion from potable water therein, during the first THREE years after initial installation, the warrantor will supply a replacement tank less burner and controls or a complete new State water heater of equivalent size and current model at the warrantor's option. Some government agencies are requiring energy efficient standards for water heaters. In the event regulations prohibit sale of a model of equivalent size and construction, State will provide a model which complies with the regulations of your area, in which case the consumer will be charged the difference in price between the like replacement and the energy efficient model required. The warranty on the replacement water heater will be limited to the unexpired term of the original warranty.

### 2. ALL OTHER PARTS

If within ONE year after initial installation of this water heater, any part or portion shall prove upon examination by the warrantor to be defective in material or workmanship, the warrantor will repair or replace such part or portion at its option.

### 3. CONDITIONS AND EXCEPTIONS

This warranty shall apply only when the water heater is installed in accordance with local plumbing and building codes, ordinances and regulations, the printed instructions provided with it and good industry practices. In addition, a temperature and pressure relief valve, certified by CSA and approved by the American Society of Mechanical Engineers, must have been installed.

a. This warranty shall apply only when the water heater is:

- (1) owned by the original purchaser;
- (2) used at temperatures not exceeding the maximum setting of its thermostat;
- (3) used at water pressure not exceeding the working pressure shown on the heater;
- (4) used when operated free of the damaging effects of uncontrolled water hammer;
- (5) used when filled with potable water, free to circulate at all times;
- (6) used in a non-corrosive and non-contaminated atmosphere;
- (7) used with factory approved anode(s) installed;
- (8) in its original installation location;
- (9) in the United States, its territories or possessions, and Canada;
- (10) sized in accordance with proper sizing techniques for commercial water heaters;
- (11) bearing a rating plate which has not been altered, defaced or removed except as required by the warrantor;
- (12) fired at the factory rated input using the fuel stated on the rating plate;
- (13) maintained in accordance with the instructions printed in the manual included with the water heater.

b. Any accident to the water heater, any misuse, abuse (including freezing) or alteration of it, any operation of it in a modified form, or any attempt to repair tank leaks will void this warranty.

c. This warranty is void if a device acting as a backflow prevention device (check valves etc.) is installed in the cold water supply the heater is connected to, unless an effective method of controlling thermal expansion is also installed at the heater(s) and operational at all times.

The temperature and pressure relief valve installed on the heater is not an acceptable method.

### 4. SERVICE AND REPAIR EXPENSES

Under the limited warranty the warrantor will provide only a replacement water heater or part thereof. The owner is responsible for all other costs. Such costs may include but are not limited to:

- a. Labor charges for service removal, repair or reinstallation of the water heater or any component part;
- b. Shipping, delivery, handling, and administrative charges for forwarding the new heater or replacement part from the nearest distributor and returning the claimed defective heater or part to such distributor.
- c. All cost necessary or incidental for any material and/or permits required for installation of the replacement.

### 5. LIMITATIONS ON IMPLIED WARRANTIES

Implied warranties, including the warranty of merchantability imposed on the sale of this heater under state law are limited to one (1) year duration for the heater or any of its parts. Some states do not allow limitations on how long an implied warranty lasts, so the above limitation may not apply to you.

### 6. CLAIM PROCEDURE

Any claim under the warranty should be initiated with the dealer who sold the water heater, or with any other dealer handling the warrantor's products. If this is not practicable, the owner should contact:

U.S. Customers  
State Water Heaters  
500 Tennessee Waltz Parkway  
Ashland City, TN 37015  
Telephone: 1-(800)-365-0024

Canadian Customers  
State Water Heaters  
P. O. Box, 310 - 768 Erie Street  
Stratford (Ontario) N5A 6T3  
Telephone: 1-(800) 265-8520

- a. The warrantor will only honor replacement with identical or similar water heater or parts thereof which are manufactured or distributed by the warrantor.
- b. Dealer replacements are made subject to in-warranty validation by warrantor.

### 7. DISCLAIMERS

NO OTHER EXPRESS WARRANTY HAS BEEN OR WILL BE MADE IN BEHALF OF THE WARRANTOR WITH RESPECT TO THE MERCHANTABILITY OF THE HEATER OR THE INSTALLATION, OPERATION, REPAIR OR REPLACEMENT OF THE WATER HEATER. THE WARRANTOR SHALL NOT BE RESPONSIBLE FOR WATER DAMAGE, LOSS OF USE OF THE UNIT, INCONVENIENCE, LOSS OR DAMAGE TO PERSONAL PROPERTY OR OTHER CONSEQUENTIAL DAMAGE. THE WARRANTOR SHALL NOT BE LIABLE BY VIRTUE OF THIS WARRANTY OR OTHERWISE FOR DAMAGE TO ANY PERSONS OR PROPERTY, WHETHER DIRECT OR INDIRECT, AND WHETHER ARISING IN CONTRACT OR TORT.

- a. Some states do not allow the exclusion or limitation of the incidental or consequential damage, so the above limitations or exclusions may not apply to you.
- b. This warranty gives you specific legal rights, and you may also have other rights which vary from state to state.

Fill in the following for your own reference. Keep it. Registration is not a condition of warranty. The model and serial number are found on the heater's rating plate.

Date Installed \_\_\_\_\_ Model No. \_\_\_\_\_ Serial No. \_\_\_\_\_

Dealer's Name \_\_\_\_\_ Phone No. \_\_\_\_\_

Dealer's Address \_\_\_\_\_ City and State \_\_\_\_\_ Zip Code \_\_\_\_\_

**FILL IN WARRANTY AND KEEP FOR FUTURE REFERENCE.**





500 Tennessee Waltz Parkway, Ashland City, TN 37015  
Phone: 800-365-0024 • Fax: 800-644-9306  
[www.statewaterheaters.com](http://www.statewaterheaters.com)