

# Outdoor Tankless Water Heater

## Operation and Installation Manual

**Models:**

**305**

**505**

**705**

**FOR OUTDOOR APPLICATIONS ONLY**

**Models 305 and 505 are Energy Star Qualified**

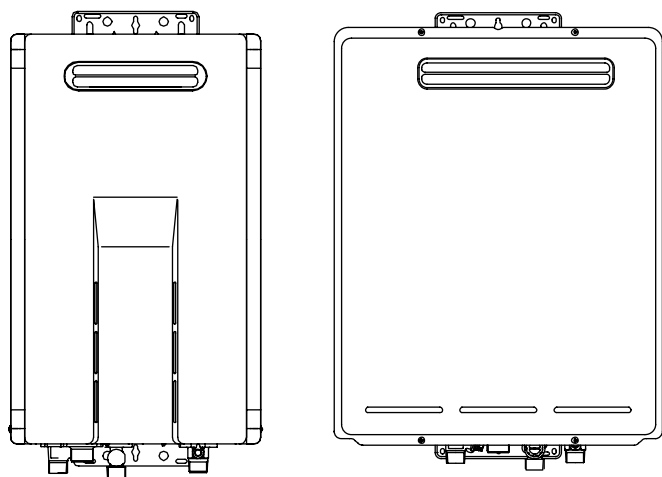

Table of Contents .....	2
Consumer Safety Information ..	4
Operating Instructions.....	5
Maintenance .....	8
Error Codes .....	9
Installation Instructions .....	13
Warranty .....	32



**ANS Z21.10.3**

**CSA 4.3**

**INSTALLER:** Leave this manual with the appliance.  
**CONSUMER:** Retain this manual for future reference.

**WARNING:** If the information in these instructions is not followed exactly, a fire or explosion may result causing property damage, personal injury or death.

- Do not store or use gasoline or other flammable vapors and liquids in the vicinity of this or any other appliance.
- **WHAT TO DO IF YOU SMELL GAS**
  - Do not try to light any appliance.
  - Do not touch any electrical switch; do not use any phone in your building.
  - Immediately call your gas supplier from a neighbor's phone. Follow the gas supplier's instructions.
  - If you cannot reach your gas supplier, call the fire department.
- Installation and service must be performed by a qualified installer, service agency or the gas supplier.

# Table of Contents

<p><b>Specifications</b> ..... 3</p> <p><b>Consumer Safety Information</b></p> <p style="padding-left: 20px;"><i>Safety Definitions</i>..... 4</p> <p style="padding-left: 20px;"><i>Safety Behaviors and Practices</i>..... 4</p> <p style="padding-left: 20px;"><i>Safety Features</i> ..... 4</p> <p><b>Description of Operation</b> ..... 5</p> <p><b>Operating Instructions</b></p> <p style="padding-left: 20px;"><i>Features Available on Temperature Controllers</i> ..... 5</p> <p style="padding-left: 20px;"><i>Setting the Temperature</i>..... 6</p> <p style="padding-left: 20px;"><i>Temperature Options Without a Temperature Controller</i> ..... 6</p> <p style="padding-left: 20px;"><i>Temperature Ranges</i>..... 7</p> <p style="padding-left: 20px;"><i>Setting Controller to Mute</i>..... 7</p> <p style="padding-left: 20px;"><b>Maintenance</b></p> <p style="padding-left: 40px;">Cleaning ..... 8</p> <p style="padding-left: 40px;">Air Intake and Exhaust..... 8</p> <p style="padding-left: 40px;">Motors ..... 8</p> <p style="padding-left: 40px;">Temperature Controller..... 8</p> <p style="padding-left: 40px;">Lime / Scale Build-up ..... 8</p> <p style="padding-left: 40px;">Snow Accumulation..... 8</p> <p style="padding-left: 40px;">Visual Inspection of Flame ..... 8</p> <p><b>Error Codes</b></p> <p style="padding-left: 20px;"><i>Error Code Table</i> ..... 9, 10</p> <p style="padding-left: 20px;"><i>Trouble Shooting for Common Issues</i>..... 11</p> <p style="padding-left: 20px;"><i>Accessing Operating Information</i> ..... 11</p> <p style="padding-left: 20px;"><i>Water Quality</i>..... 11</p> <p style="padding-left: 20px;"><i>Flushing the Heat Exchanger</i> ..... 12</p> <p style="padding-left: 20px;"><i>(Error Code: LC or 00)</i></p>	<p><b>Installation Instructions</b> ..... 13</p> <p style="padding-left: 20px;"><i>General Instructions</i> ..... 13</p> <p style="padding-left: 20px;"><i>Clearances from Appliance</i> ..... 14</p> <p style="padding-left: 20px;"><i>Attachment of the Water Heater</i>..... 14</p> <p style="padding-left: 20px;"><i>Electrical Connection</i>..... 15</p> <p style="padding-left: 20px;"><b>Gas Piping</b></p> <p style="padding-left: 40px;">General Instructions ..... 15</p> <p style="padding-left: 40px;">Pipe Sizing Procedure - Example ..... 16</p> <p style="padding-left: 20px;"><b>Water Piping</b></p> <p style="padding-left: 40px;">General Instructions ..... 17</p> <p style="padding-left: 40px;">Pressure Relief Valve..... 17</p> <p style="padding-left: 40px;">Freeze Protection ..... 17</p> <p style="padding-left: 20px;"><i>Freeze Protection Piping</i> ..... 18</p> <p style="padding-left: 20px;"><i>Recommended Piping for Basic Installation..</i> 19</p> <p style="padding-left: 20px;"><i>Recommended Piping for Circulation Systems</i>..... 20</p> <p style="padding-left: 20px;"><i>Optional Piping for Circulation Systems</i> ..... 21</p> <p style="padding-left: 20px;"><i>Flue Terminal Clearances (ANS Z21.10.3 • CSA 4.3)</i>..... 22</p> <p style="padding-left: 20px;"><i>Additional Clearances</i>..... 23</p> <p style="padding-left: 20px;"><i>High Altitude Installation</i> ..... 24</p> <p style="padding-left: 20px;"><i>Connecting Multiple Water Heaters</i>..... 24</p> <p style="padding-left: 20px;"><b>Temperature Controller Installation</b></p> <p style="padding-left: 40px;">Location ..... 25</p> <p style="padding-left: 40px;">Configurations ..... 25</p> <p style="padding-left: 40px;">Cable Lengths and Size ..... 25</p> <p style="padding-left: 40px;">Mounting the Controller ..... 26</p> <p style="padding-left: 20px;"><i>Operating Instructions</i> ..... 27</p> <p><b>Technical Data</b></p> <p style="padding-left: 20px;"><i>Pressure Drop Curve</i>..... 28</p> <p style="padding-left: 20px;"><i>Outlet Flow Data</i>..... 28</p> <p style="padding-left: 20px;"><i>Space Heating</i> ..... 29</p> <p style="padding-left: 20px;"><i>Dimensions</i>..... 30</p> <p style="padding-left: 20px;"><i>Ladder Diagram</i>..... 31</p> <p><b>Warranty</b> ..... 32, 33</p>
--	--

# Specifications

Model		305	505	705
Minimum Gas Consumption Btu/h		15,000		19,000
Maximum Gas Consumption Btu/h		180,000	199,000	237,000
Hot water capacity (Min - Max) *		0.6 - 7.5 GPM (2.3 - 28.4 L/min)	0.6 - 9.4 GPM (2.3 - 35.5 L/min)	0.6 - 9.8 GPM (2.3 - 37 L/min)
Hot water capacity (45°F rise)		6.6 GPM (25.0 L/min)	7.4 GPM (28.0 L/min)	8.7 GPM (33.1 L/min)
Default Temperature Setting (no controller)		120° F (49° C)		
Temperature controller Default Setting		104° F (40° C)		
Maximum Temp Setting (Commercial) **		160° F (71° C)	185° F (85° C)	
Maximum Temp Setting (Residential)		Selectable at 120° F (49° C) or at 140° F (60° C)		140° F (60° C)
Minimum Temperature Setting		98° F (37° C)		
Weight		46 lb (21 kg)		55 lb (25 kg)
Efficiency Rating		83%		
Noise level		49 dB		
Electrical Consumption	Normal	50 W	55 W	72 W
	Standby	2 W		
	Anti-frost Protection	100 W		116 W
By-Pass Control		Fixed	Electronic	
Minimum Gas Supply Pressure	Natural Gas	5.0 inch W.C.		
	Propane	8.0 inch W.C.		
Maximum Gas Supply Pressure	Natural Gas	10.5 inch W.C.		
	Propane	13.5 inch W.C.		
Type of Appliance		Temperature controlled continuous flow gas hot water system.		
Operation		With or without temperature controls, mounted in kitchen, bathroom, etc.		
Approved Gas Type		Natural Gas or Propane - Ensure unit matches gas type being used.		
Connections		Gas Supply: 3/4" MNPT, Cold Water Inlet: 3/4" MNPT, Hot Water Outlet: 3/4" MNPT		
Ignition System		Direct Electronic Ignition		
Electric Connections		Appliance: AC 120 Volts, 60Hz. Temperature Control: DC 12 Volts (Digital)		
Water Temperature Control		Simulation Feedforward and Feedback.		
Water Supply Pressure		Minimum Water Pressure: 20 PSI (Recommended 30-80 PSI for maximum performance)		
Maximum Water Supply Pressure		150 PSI		
Temperature Controller Cable		Non-Polarized Two Core Cable (Minimum 22 AWG)		
Energy Star Qualified		Yes	Yes	No

\* Minimum flow may vary slightly depending on the temperature setting and the inlet water temperature.

\*\* for commercial and hydronic applications requiring higher temperatures

Specifications are subject to change without prior notice.

The maximum inlet gas pressure must not exceed the value specified by the manufacturer. The minimum value listed is for the purpose of input adjustment.

# Consumer Safety Information

## Safety Definitions

---



This is the safety alert symbol. This symbol alerts you to potential hazards that can kill or hurt you and others.



Indicates an imminently hazardous situation which, if not avoided, will result in death or serious injury.



Indicates a potentially hazardous situation which, if not avoided, could result in death or serious injury.



Indicates a potentially hazardous situation which, if not avoided, could result in minor or moderate injury. It may also be used to alert against unsafe practices.

## Safety Behavior and Practices

---



- Keep the area around the appliance clear and free from combustible materials, gasoline, and other flammable vapors and liquids.
- Do not use this appliance if any part has been under water. Immediately call a qualified service technician to inspect the appliance and to replace any part of the control system and any gas control which has been under water.
- Any alteration to the appliance or its controls can be dangerous and will void the warranty.
- Always check the water temperature before entering a shower or bath.

## Safety Features

---

- **Overheat:** The appliance will automatically shut down when the appliance exceeds a predetermined temperature.
- **Flame Failure:** The appliance will automatically shut down if the burner flame is extinguished.
- **Power Failure:** The appliance will cut off the gas if it loses electrical power.
- **Power Surge Fuse:** A glass fuse protects against overcurrent. If the fuse blows then all indicator lamps will be off.
- **Fusible Link:** In case the overheat feature does not prevent the temperature from rising then the fusible link will break shutting off the appliance.

## Description of Operation

This appliance is one of the most advanced water heaters available. It provides a continuous supply of hot water at a preset temperature. This appliance is direct vent where air is brought in from the outside and combustion gases are exhausted to the outside.

While electricity, water, and gas supplies are connected, this appliance produces hot water whenever a hot water tap is open.

Ignition is electronic. There is no pilot light consuming gas while the water heater is not being used. The gas burner lights automatically when the hot water tap is

opened and goes out when the tap is closed.

Installation of the temperature controller is highly recommended. The temperature controller can set the temperature within a specific range and can provide error codes to diagnose any problems.

The temperature of the outgoing hot water is constantly monitored. This appliance may adjust the water flow in order to maintain the temperature setting. The water flow may vary from summer to winter due to the difference in ground water temperature.

## Operating Instructions

### Features Available on Temperature Controllers

The temperature controller is supplied with the appliance. Dimensions (inches): 3.5 W x 4.75 H x 0.75 D

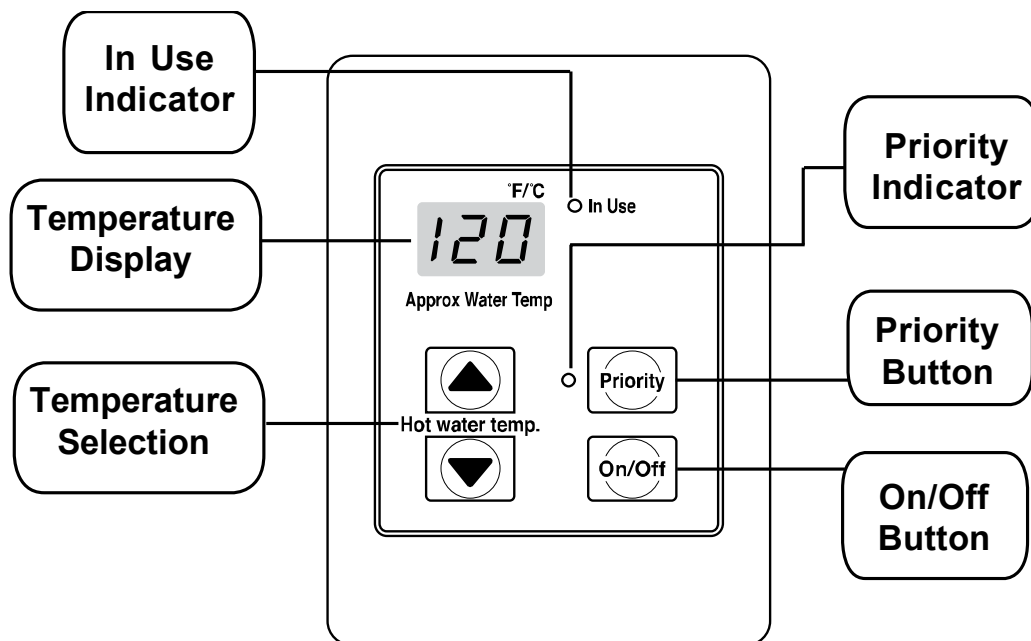

Features	Description
Error Codes	When a fault is detected an error code flashes at the temperature
In Use Indicator	Indicates that hot water is being supplied (i.e. a hot water tap is open).
On/Off Button	Used to turn the water heater On or Off.
Priority Button / Indicator	Indicates that this controller is setting the temperature . Priority can be switched to another controller by pressing its Priority Button when no hot water is running.
Temperature Display	Shows the temperature setting.
Thermostat	Increases or decreases the temperature setting.

## Setting the Temperature



Hot water can be dangerous, especially for infants or children, the elderly, or infirm. There is hot water scald potential if the thermostat is set too high.

Water temperatures over 125° F (51° C) can cause severe burns or scalding resulting in death.

Hot water can cause first degree burns with exposure for as little as:

3 seconds at 140° F (60° C)

20 seconds at 130° F (54° C)

8 minutes at 120° F (48° C)

Test the temperature of the water before placing a child in the bath or shower.

Do not leave a child or an infirm person in the bath unsupervised.



1. Press the "Priority button" on the temperature controller. The green Priority light will glow indicating that this controller is controlling the temperature and that the water heater is ready to supply hot water.

The priority can only be changed while no hot water is running.



Hot water temp.



2. Press the ▲ or ▼ buttons to obtain the desired temperature setting.

All hot water sources are able to provide water at this temperature setting until it is changed again at this or another temperature controller.

### NOTICE

While any hot water is being provided, the temperature setting can only be adjusted between 98° F and 110° F.

### NOTICE

Check local codes for the maximum water temperature setting allowed when used in nursing homes, schools, day care centers, and all other public applications.

### NOTICE

If a newly installed unit with a temperature controller has not been powered for at least 6 hours then the temperature will return to the default setting of 104° F (40° C) if power is interrupted.

### NOTICE

There may be a variation between the temperature displayed on the temperature controller and the temperature at the tap due to weather conditions or the length of pipe to the water heater.

## Temperature Options Without a Temperature Controller

The default temperature setting for this appliance installed without a temperature controller is 120° F (49° C). If desired the temperature setting can be changed to 140° F (60° C) by adjustment of a dip switch.

Set dip switch 5 to ON to obtain 140° F water temperature setting.

Set dip switch 5 to OFF (default) to obtain 120° F

**WARNING** DO NOT adjust the other dip switches unless specifically instructed to do so.

120° F (49° C)

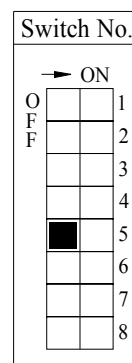

140° F (60° C)

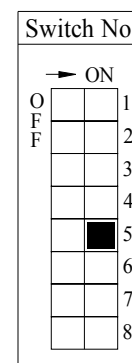

## Temperature Ranges

This water heater will attempt to provide hot water at the temperature setting even when the water flow is varied or when more than 1 tap is in use. The water heater can deliver water at only one temperature setting at a time. The available temperatures for a given model are provided below.

Model	Temperature Settings Available (°F)															
	98	100	102	104	106	108	110	115	120	125*	130*	135*	140*	150**	160**	
<b>305</b>	98	100	102	104	106	108	110	115	120	125*	130*	135*	140*	150**	160**	
<b>505</b>	98	100	102	104	106	108	110	115	120	125*	130*	135*	140*	150**	160**	185**
<b>705</b>	98	100	102	104	106	108	110	115	120	125	130	135	140	150**	160**	185**
Temp in Celsius °C	37	38	39	40	41	42	43	46	49	52	54	57	60	66	71	85

### \* Re-setting the Maximum Temperature

Models 305 and 505 have a default maximum temperature of 120° F (49° C) and an option to increase the maximum temperature to 140 °F (60 °C). Temperature settings from 125-140 °F (52-60 °C) are available by setting dip switch 6 to ON in the SW1 bank of 8 dip switches.

Model 705 has a default maximum temperature of 140 °F (60 °C).

### \*\* Commercial Controller

These settings require the commercial controller which is for commercial and hydronic applications requiring higher temperatures. When the commercial controller is connected, these higher temperatures are available on all controller models in the system.

The commercial controller is intended for commercial and hydronic applications only. If commercial controller is used in a residential dwelling for a hydronics application, a mixing valve must also be installed to limit the potable hot water temperature to a safe temperature. Water temperatures over 125° F (51° C) can cause severe burns or scalding. Refer to the Danger Alert on water temperatures. The manufacturer shall not, in any event, be liable for damages resulting from such misuse or misapplication.

Suggested temperatures are

- Kitchen 120 °F (49° C)
- Shower 98° - 110° F (37° - 43° C)

These temperatures are suggestions only.

A temperature lower than 98° F (37° C) can be obtained at the tap by mixing with cold water.

To change the temperature scale from Celsius to Fahrenheit or vice versa, press and hold the “On/Off” button for 5 seconds while the water heater is OFF.

## Setting Controller to Mute

To eliminate the beeps when keys are pressed or to turn the beeps back on, press and hold both the ▲ and ▼ buttons until a beep is heard (approximately 5 seconds).

### **WARNING**

Turn off the electrical power supply, the manual gas valve and the manual water control valve whenever servicing the unit.

Repairs should be performed by a qualified service technician. The appliance should be inspected at least annually by a qualified service technician. Verify proper operation after servicing.

### **Cleaning**

It is imperative that control compartments, burners, and circulating air passageways of the appliance be kept clean.

Clean as follows:

1. Turn off and disconnect electrical power. Allow to cool.
2. Remove and clean the water inlet filter.
3. Remove the front panel by removing 4 screws.
4. Use pressurized air to remove dust from the main burner, heat exchanger, and fan blades. Do not use a wet cloth or spray cleaners on the burner. Do not use volatile substances such as benzene and thinners. They may ignite or fade the paint.
5. Use soft dry cloth to wipe cabinet.

### **Air Intake and Exhaust**

The air intake and exhaust should be inspected at least annually for blockages or damage.

### **Motors**

Motors are permanently lubricated and do not need periodic lubrication. Keep fan and motor free of dust and dirt by cleaning annually.

### **Temperature Controller**

Use a soft damp cloth to clean the temperature controller. Do not use solvents.

### **Lime / Scale Build-up**

If you receive Error Code "LC", refer to the procedure, *Flushing the Heat Exchanger*. Refer to the section on *Water Quality* to see if your water needs to be treated or conditioned. (When checking maintenance code history, "00" is substituted for "LC".)

### **Snow Accumulation**

Keep the area around the air intake and exhaust free of snow and ice. The appliance will not function properly if the intake air or exhaust is impeded (blocked or partially blocked) by obstructions.

### **Visual Inspection of Flame**

The burner must flame evenly over the entire surface when operating correctly. The flame must burn with a clear, blue, stable flame. See the parts breakdown of the burner for the location of the view ports.

The flame pattern should be as shown in the figures below.

#### **SATISFACTORY**

##### **FRONT VIEW**

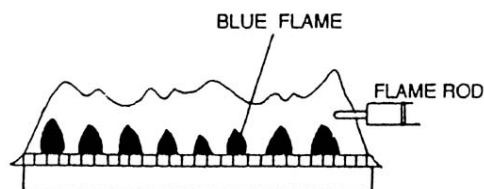

#### **UNSATISFACTORY**

##### **FRONT VIEW**

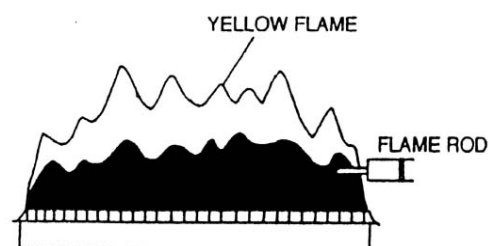



## Error Codes

This appliance has the ability to check its own operation continuously. If a fault occurs, an error code will flash on the Display of the temperature controller. This assists with diagnosing the fault and may enable you to overcome a problem without a service call. Please identify the code displayed when inquiring about service.

**⚠ WARNING** Some of the checks below may need to be done by a qualified service technician. Call a service technician for any remedy that involves gas or electricity. Call a service technician if you have any doubt or reservation about performing the remedy yourself.

### *Error Code Table*

Code	Fault	Remedy
02	No burner operation during freeze protection mode	Service Call
10	Air Supply or Exhaust Blockage	Check that nothing is blocking the inlet or exhaust. Verify dip switches are set properly. Check fan for blockage.
11	No Ignition	Check that the gas is turned on at the water heater, gas meter, or cylinder. Ensure gas type and pressure is correct. Ensure gas line, meter, and/or regulator is sized properly. Bleed all air from gas lines. Verify dip switches are set properly. Ensure appliance is properly grounded. Disconnect all 2-Unit or Multi-Unit connections to isolate the problem. Ensure igniter is operational. Check igniter wiring harness for damage. Check gas solenoid valves for open or short circuits. Remove burner cover and ensure all burners are properly seated. Remove burner plate and inspect burner surface for condensation or debris.
12	Flame Failure	Check that the gas is turned on at the water heater and gas meter. Check for obstructions in the flue outlet. Ensure gas line, meter, and/or regulator is sized properly. Ensure gas type and pressure is correct. Bleed all air from gas lines. Verify dip switches are set properly. Ensure appliance is properly grounded. Disconnect keypad. Disconnect all 2-Unit or Multi-Unit connections to isolate the problem. Check power supply for loose connections. Check power supply for proper voltage and voltage drops. Ensure flame rod wire is connected. Check flame rod for carbon build-up. Disconnect and re-connect all wiring harnesses on unit and PC board. Check all components for electrical short. Check gas solenoid valves for open or short circuits. Remove burner plate and inspect burner surface for condensation or debris.

## Error Code Table

Code	Fault	Remedy
14	Thermal Fuse	<p>Check gas type of unit and ensure it matches gas type being used.</p> <p>Check for restrictions in air flow around unit and vent terminal.</p> <p>Check for low water flow in a circulating system causing short-cycling.</p> <p>Ensure dip switches are set to the proper position.</p> <p>Check for foreign materials in combustion chamber and/or exhaust piping.</p> <p>Check heat exchanger for cracks and/or separations.</p> <p>Check heat exchanger surface for hot spots which indicate blockage due to scale build-up. Refer to instructions in manual for flushing heat exchanger.</p> <p>Measure resistance of safety circuit.</p> <p>Ensure high fire and low fire manifold pressure is correct.</p> <p>Check for improper conversion of product.</p>
16	Over Temperature Warning	<p>Check for restrictions in air flow around unit, air intake and exhaust.</p> <p>Check for low water flow in a circulating system causing short-cycling.</p> <p>Check for foreign materials in combustion chamber and/or exhaust piping.</p> <p>Check for clogged heat exchanger.</p>
32	Outgoing Water Temperature Sensor Fault	<p>Check sensor wiring for damage.</p> <p>Measure resistance of sensor.</p> <p>Clean sensor of scale build-up.</p> <p>Replace sensor.</p>
33	Heat Exchanger Outgoing Temperature Sensor Fault	<p>Check sensor wiring for damage.</p> <p>Measure resistance of sensor.</p> <p>Clean sensor of scale build-up.</p> <p>Replace sensor.</p>
52	Modulating Solenoid Valve Signal Abnormal	<p>Check modulating gas solenoid valve wiring harness for loose or damaged terminals.</p> <p>Measure resistance of valve coil.</p>
61	Combustion Fan Failure	<p>Ensure fan will turn freely.</p> <p>Check wiring harness to motor for damaged and/or loose connections.</p> <p>Measure resistance of motor winding.</p>
71	SV0, SV1, SV2, and SV3 Solenoid Valve Circuit Fault	<p>Check wiring harness to all solenoids for damage and/or loose connections.</p> <p>Measure resistance of each solenoid valve coil.</p>
72	Flame Sensing Device Fault	<p>Ensure flame rod is touching flame when unit fires.</p> <p>Check all wiring to flame rod for damage.</p> <p>Remove flame rod and check for carbon build-up; clean with sand paper.</p> <p>Check inside burner chamber for any foreign material blocking flame at flame rod.</p> <p>Measure micro amp output of sensor circuit with flame present.</p> <p>Replace flame rod.</p>
LC	Scale Build-up in Heat Exchanger (when checking maintenance code history "00" is substituted for "LC")	<p>Flush heat exchanger. Refer to instructions in manual.</p> <p>Replace heat exchanger.</p>
No code	Nothing happens when water flow is activated.	<p>Clean inlet water supply filter.</p> <p>On new installations ensure hot and cold water lines are not reversed.</p> <p>Check for bleed over. Isolate unit from building by turning off hot water line to building. Isolate the circulating system if present. Open your pressure relief valve; if water is flowing, there is bleed over in your plumbing.</p> <p>Ensure you have at least the minimum flow rate required to fire unit.</p> <p>Ensure turbine spins freely.</p> <p>Measure the resistance of the water flow control sensor.</p> <p>Check for DC shorts at components</p>

## Trouble Shooting for Common Issues

### **I don't have any hot water when I open the tap.**

*Make sure there is gas, water, and electricity to the water heater (power is turned on and the gas is turned on).*

### **When I was using the hot water, the water got cold.**

*If you adjusted the flow from the tap to lessen it, you may have gone below the minimum flow required. This water heater requires a minimum flow rate to operate. (See the specification page for the flow rate of your model.) Decrease the temperature setting at the temperature controller or increase the water flow.*

### **White smoke comes out of the exhaust.**

*During colder weather when the exhaust temperature is much hotter than the outside air, the exhaust fumes condense producing water vapor.*

### **When I open a hot tap, I do not immediately get hot water.**

*Hot water must travel through your plumbing from the water heater to the faucet. The time period for hot water to reach your fixture is determined by the amount of water in the plumbing system between the water heater and the fixture, water pressure, and the flow rate of the fixture.*

### **After I turn off the hot water tap, the fan on the water heater continues to run.**

*The fan is designed to continue running for a short time after the flow of water stops. This is to ensure constant water temperatures during rapid starting and stopping, as well as exhausting any residual gas flue products from the unit.*

---

## Accessing Operating Information

To display the most recent error codes press and hold the "On/Off" button for 2 seconds. While holding the "On/Off" button press the ▲ button. The last 9 error codes will flash one after the other. To exit this mode press the "On/Off" and ▲ button as before.

To display the water flow through the water heater press and hold the ▲ button for 2 seconds and without releasing the ▲ button press the "On/Off" button.

To display the outlet water temperature press and hold the ▼ button for 2 seconds and without releasing the ▼ button press the "On/Off" button.

---

## Water Quality

Consideration of care for your water heater should include evaluation of water quality. If the water quality exceeds the target levels provided in the table, you may want to treat or condition the water.

\* Source: Part 143 National Secondary Drinking Water Regulations

	<b>Maximum Level</b>
Total Hardness	Up to 200 mg / L
Aluminum *	Up to 0.2 mg / L
Chlorides *	Up to 250 mg / L
Copper *	Up to 1.0 mg / L
Iron *	Up to 0.3 mg / L
Manganese *	Up to 0.05 mg / L
pH *	6.5 to 8.5
TDS (Total Dissolved Solids) *	Up to 500 mg / L
Zinc *	Up to 5 mg / L

## Flushing the Heat Exchanger (Error Code: LC or 00)

An "LC" or "00" error code indicates the unit is beginning to lime up and must be flushed. Failure to flush the appliance will cause damage to the heat exchanger. Damage caused by lime build-up is not covered by the unit's warranty. After flushing, reset the LC fault code by turning off the power to the unit and turning the power back on.

1. Disconnect electrical power to the water heater.
2. Close the shutoff valves on both the hot water and cold water lines (V3 and V4).
3. Connect pump outlet hose (H1) to the cold water line at service valve V2.
4. Connect drain hose (H3) to service valve V1.
5. Pour approximately 4 gallons of virgin, food grade, white vinegar or citric acid into pail.
6. Place the drain hose (H3) and the hose (H2) to the pump inlet into the cleaning solution.
7. Open both service valves (V1 and V2) on the hot water and cold water lines.
8. Operate the pump and allow the cleaning solution to circulate through the water heater for at least 45 minutes.
9. Turn off the pump.
10. Rinse the cleaning solution from the water heater as follows:
  - a. Remove the free end of the drain hose (H3) from the pail.
  - b. Close service valve, (V2), and open shutoff valve, (V4). Do not open shutoff valve, (V3).
  - c. Allow water to flow through the water heater for 5 minutes
  - d. Close service valve, (V1), and open shutoff valve, (V3).
11. Disconnect all hoses.
12. Remove the in-line filter at the cold water inlet and clean out any residue. Place filter back into unit.
13. Restore electrical power to the water heater.

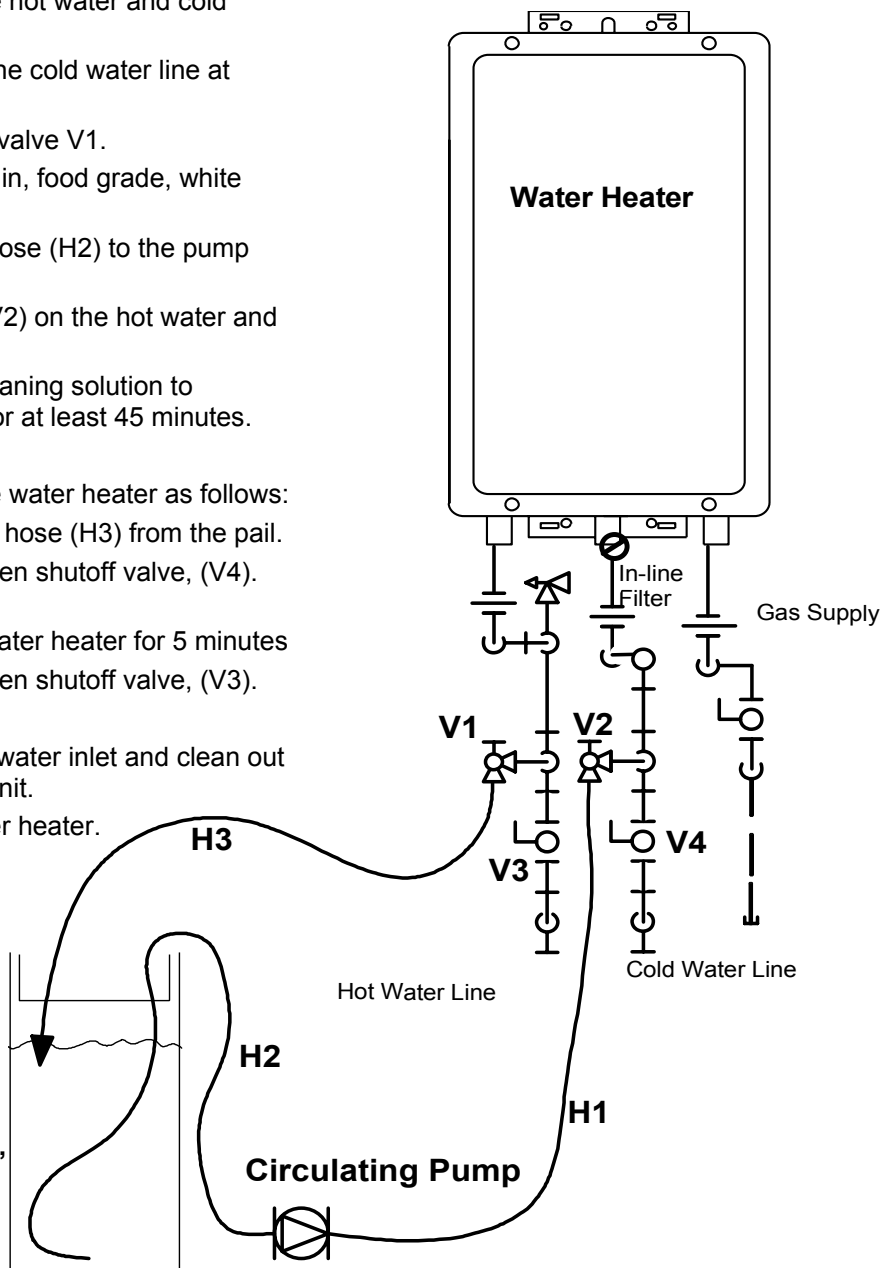

### KEY

	3/4" Ball Valve		Pressure Regulator
	3/4" Union		Circulating Pump
	Check Valve		Boiler Drain Valve
	Pressure Relief Valve		Solenoid Valve

# Installation Instructions

Only properly trained and qualified installers should install this appliance. The warranty may be voided due to improper installation or installation by a non-qualified installer.

It is highly recommended that all installers attend a product knowledge class.

## General Instructions

### **WARNING**

Do not use substitute materials.

Use only parts certified with the appliance.

- This appliance must be installed by a state qualified or licensed contractor. It is the responsibility of the person having the water heater installed to ensure the installing contractor has proper licenses and permits for installing water heaters in your location. It is highly recommended that installers attend a product knowledge class to ensure customer satisfaction and warranty coverage. Failure to comply with state and local codes pertaining to water heater installations may void the warranty.
- This appliance is not to be installed indoors.
- A qualified installer or service technician should install the appliance, inspect it, and leak test it before use.
- The installation must conform with local codes or, in the absence of local codes, with the *National Fuel Gas Code, ANSI Z223.1/NFPA 54*, or the *Natural Gas and Propane Installation Code, CSA B149.1*.
- The appliance, when installed, must be electrically grounded in accordance with local codes or, in the absence of local codes, with the *National Electrical Code, ANSI/NFPA 70*, or the *Canadian Electrical Code, CSA C22.1*.
- The appliance and its appliance main gas valve must be disconnected from the gas supply piping system during any pressure testing of that system at test pressures in excess of 1/2 psi (3.5 kPa) (13.84 in W.C.).
- The appliance must be isolated from the gas supply piping system by closing its individual manual shutoff valve during any pressure testing of the gas supply piping system at test pressures equal to or less than 1/2 psi (3.5 kPa) (13.84 in W.C.).
- Follow the installation instructions and those in *Care and Maintenance* for adequate combustion and ventilation air.
- The appliance should be located in an area where water leakage of the unit or connections will not result in damage to the area adjacent to the appliance or to lower floors of the structure. When such locations cannot be avoided, it is recommended that a suitable drain pan, adequately drained, be installed under the appliance. The pan must not restrict combustion air flow.
- The flow of combustion and ventilation air shall not be obstructed.
- This appliance is not suitable for use in an application such as a pool or spa heater that uses chemically treated water. (This appliance is suitable for filling large or whirlpool bath tubs with potable water.)
- If a water heater is installed in a closed water supply system, such as one having a backflow preventer in the cold water supply line, means shall be provided to control thermal expansion. Contact the water supplier or local plumbing inspector on how to control thermal expansion.
- Should overheating occur or the gas supply fail to shut off, turn off the manual gas control valve to the appliance.
- Keep the air intake location free of chemicals such as chlorine or bleach that produce fumes. These fumes can damage components and reduce the life of your appliance.

## Clearances from Appliance

	to Combustibles	to Non-Combustibles
Top of Heater	12 inches (305 mm)	2 inches (51 mm)
Back of Heater	0 (zero)	0 (zero)
Front (Panel)	24 inches (610 mm)	* 0 inches (0 mm)
Front (Exhaust)	24 inches (610 mm)	24 inches (610 mm)
Sides of Heater	6 inches (152 mm)	1/8 inch (3.2 mm)
Floor/ Ground	12 inches (305 mm)	2 inches (51 mm)

\* The clearance for servicing is 24 inches in front of the water heater.

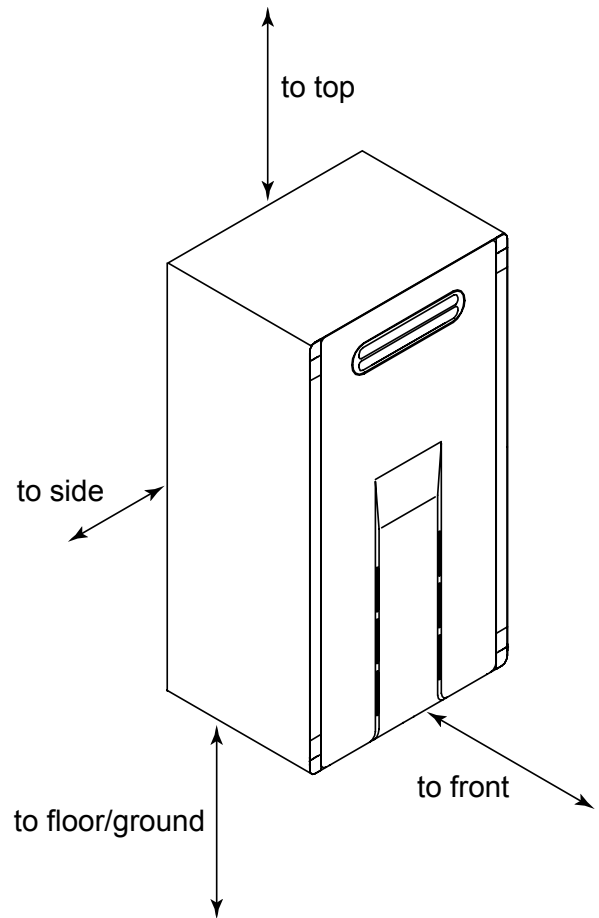

## Attachment of the Water Heater

1. Identify the installation location and confirm that the installation will meet all required clearances.
2. Securely attach the water heater to the wall using any of the holes in the wall installation brackets which are at the top and bottom of the water heater. Ensure that the attachment strength is sufficient to support the weight. Refer to the weight of the water heater in the Specifications section.

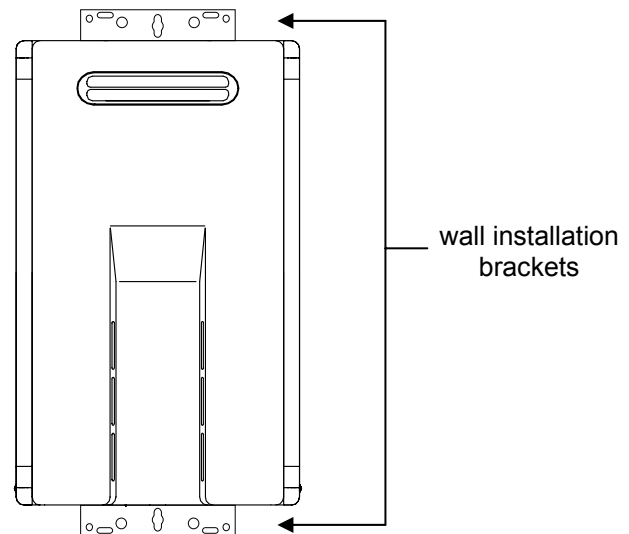

## Electrical Connection

The water heater must be electrically grounded in accordance with local codes or in the absence of local codes with the most recent edition of the National Electrical Code, ANSI/NFPA 70. Do not rely on the gas or water piping to ground the water heater. A screw is provided in the junction box for the grounding connection.

The water heater requires 120 VAC, 60 Hz power from a properly grounded circuit.

A disconnect switch must be provided and installed for the incoming 120 VAC power. It should be a type that is suitable for outdoor use. Check the National Electrical Code, ANSI/NFPA 70 and your local codes for a proper switch type to use in your area.

The wiring diagram is located on the Technical Sheet attached to the inside of the front cover.

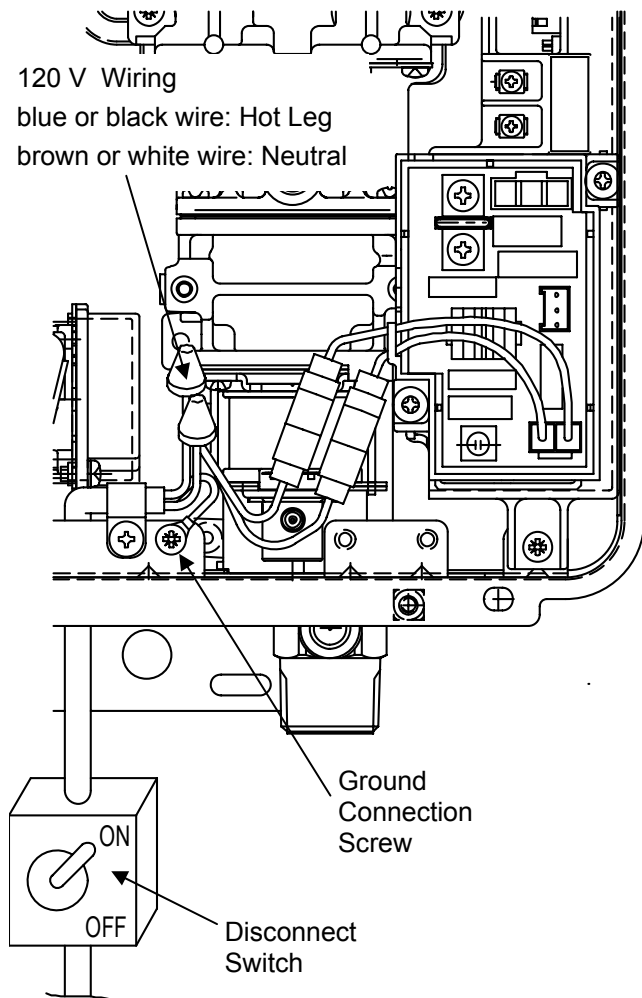

## Gas Piping

### **General Instructions**

- A manual gas control valve must be placed in the gas supply line to the water heater. A union can be used on the connection above the shut off valve for the future servicing or disconnection of the unit.
- Check the type of gas and the gas inlet pressure before connecting the water heater. If the water heater is not of the gas type that the building is supplied with, DO NOT connect the water heater. Contact the dealer for the proper unit to match the gas type.
- Check the gas supply pressure immediately upstream at a location provided by the gas company. Supplied gas pressure must be within the limits shown in the Specifications section.
- Before placing the appliance in operation all joints including the heater must be checked for gas tightness by means of leak detector solution, soap and water, or an equivalent nonflammable solution, as applicable. (Since some leak test solutions, including soap and water, may cause corrosion or stress cracking, the piping shall be rinsed with water after testing, unless it has been determined that the leak test solution is non-corrosive.)
- Always use approved connectors to connect the unit to the gas line. Always purge the gas line of any debris before connection to the water heater.
- The gas supply line shall be gas tight, sized, and so installed as to provide a supply of gas sufficient to meet the maximum demand of the heater and all other gas consuming appliances at the location without loss of pressure.
- Any compound used on the threaded joint of the gas piping shall be a type which resists the action of liquefied petroleum gas (propane / LPG).
- Refer to an approved pipe sizing chart if in doubt about the size of the gas line.

## Gas Piping

### Pipe Sizing Procedure - Example

The gas supply must be capable of handling the entire gas load at the location. Gas line sizing is based on gas type, the pressure drop in the system, the gas pressure supplied, and gas line type. Refer to the *National Fuel Gas Code, NFPA 54*, for proper gas line sizing. The below information is provided as an example.

- Determine the cubic feet per hour of gas required by dividing the gas input (on the rating plate) by the heating value of the gas (available from the local gas company). The gas input needs to include all gas products at the location and the maximum BTU usage at full load when all gas products are in use.

$$\text{Cubic Feet per Hour (CFH)} = \frac{\text{Gas Input of the water heater (BTU / HR)}}{\text{Heating Value of Gas (BTU / FT}^3\text{)}}$$

- Use the table for your gas type to find the pipe size required for your cubic feet per hour of gas and your pipe length.

Example: The heating value of propane gas for your location is 2516 BTU / FT<sup>3</sup>.

The gas input is 199,000 BTU/HR. Additional appliances at the location require 75,000 BTU/HR.

Therefore the cubic feet per hour = (199,000+75,000) / 2516 = 108.9 FT<sup>3</sup>/ HR.

If the pipe length is 100 ft then the 3/4 inch pipe size capable of supplying 197 FT<sup>3</sup>/ HR of propane gas will be adequate.

<b>Pipe Sizing Table - Natural Gas</b>				
cubic feet per hour		Schedule 40 Metallic Pipe		
Inlet Pressure: less than 2 psi (55 inches W.C.)				
Pressure Drop: 0.3 inches W.C.				
Specific Gravity: 0.60				
Length	Pipe Size (inches)			
	3/4	1	1 1/4	1 1/2
10	273	514	1060	1580
20	188	353	726	1090
30	151	284	583	873
40	129	243	499	747
50	114	215	442	662
60	104	195	400	600
70	95	179	368	552
80	89	167	343	514
90	83	157	322	482
100	79	148	304	455
125	70	131	269	403
150	63	119	244	366
175	58	109	224	336
200	54	102	209	313

<b>Pipe Sizing Table - Propane Gas</b>				
cubic feet per hour		Schedule 40 Metallic Pipe		
Inlet Pressure: 11.0 inches W.C.				
Pressure Drop: 0.5 inches W.C.				
Specific Gravity: 1.50				
Length	Pipe Size (inches)			
	1/2	3/4	1	1 1/4
10	291	608	1150	2350
20	200	418	787	1620
30	160	336	632	1300
40	137	287	541	1110
50	122	255	480	985
60	110	231	434	892
80	101	212	400	821
100	94	197	372	763
125	89	185	349	716
150	84	175	330	677
175	74	155	292	600
200	67	140	265	543



## Water Piping

---

### General Instructions

- A manual water control valve must be placed in the water inlet connection to the water heater before it is connected to the water line. Unions may be used on both the hot and cold water lines for future servicing and disconnection of the unit.
- The piping (including soldering materials) and components connected to this appliance must be approved for use in potable water systems.
- Purge the water line to remove all debris and air. Debris will damage the water heater.
- Toxic chemicals such as those used for boiler water treatment are not to be introduced to the potable water used for space heating.
- If the appliance will be used as a potable water source, it must not be connected to a system that was previously used with a nonpotable water heating appliance.
- Ensure that the water filter on the water heater is clean and installed.

---

### Pressure Relief Valve

- An approved pressure relief valve is required by the *American National Standard (ANSI Z21.10.3)* / *Canadian Standard (CSA 4.3)* for all water heating systems.
- The relief valve must comply with the standard for *Relief Valves and Automatic Gas Shutoff Devices for Hot Water Supply Systems ANSI Z21.22* and /or the standard *Temperature, Pressure, Temperature and Pressure Relief Valves and Vacuum Relief Valves, CAN1-4.4*.
- The relief valve must be rated up to 150 psi and to at least the maximum BTU/hr of the appliance.
- The discharge from the pressure relief valve should be piped to the ground or into a drain system to prevent exposure or possible burn hazards to humans or other plant or animal life. Follow local codes. Water discharged from the relief valve could cause severe burns instantly, scalds, or death.
- The pressure relief valve must be manually operated once a year to check for correct operation.
- The relief valve should be added to the hot water outlet line according to the manufacturer's instructions. DO NOT place any other type valve or shut off device between the relief valve and the water heater.
- Do not plug the relief valve and do not install any reducing fittings or other restrictions in the relief line. The relief line should allow for complete drainage of the valve and the line.
- If a relief valve discharges periodically, this may be due to thermal expansion in a closed water supply system. Contact the water supplier or local plumbing inspector on how to correct this situation. Do not plug the relief valve.
- Neither this water heater nor the *American National Standard (ANSI Z21.10.3)* / *Canadian Standard (CSA 4.3)* requires a combination temperature and pressure relief valve for this appliance. However, local codes may require a combination temperature and pressure relief valve.

---

### Freeze Protection

The freeze protection features include electrical heating elements and intermittent firing of the burner. Freeze protection may be disabled if electricity or gas is not supplied, or if there is an error preventing the water heater from functioning. Loss of freeze protection may result in water damage from a burst heat exchanger or water lines.

The installation of auto drain down solenoid valves is optional. However, it is strongly recommended that these valves be installed to prevent damage from freezing in case the normal freeze protection should become disabled. Any product damage due to freezing will not be covered by the warranty.

In addition, the solenoid valves should be connected electrically to a surge protector with terminals that attaches to the PC board in the unit. This allows the solenoid valves to operate if the water heater is disabled due to an error code.

The solenoid valves and the surge protector with terminals are available for purchase separately.

# Freeze Protection Piping

## NOTICE

Warranty does not cover damage due to freezing.

When electrical power and gas are supplied to the water heater, it will not freeze in environments as cold as -30° F when protected from direct wind exposure.

In the event of a power failure at temperatures below freezing the water heater should be drained of all water to prevent freezing damage.

The unit may be drained manually. However, it is highly recommended that drain down solenoid valves be installed that will automatically drain the unit if power is lost. It is also recommended that a surge protector with terminals be installed that attaches to the PC board in the unit and allows the solenoid valves to operate if the unit is disabled due to an error code.

When the electrical power to the water heater fails, the 3/4" solenoid valve closes (stopping the flow of water into the heater) and the 1/2" solenoid valve opens (allowing the water heater and associated piping to drain. Ensure that you run the drain for the solenoids to the outside environment to prevent discharging water inside the building causing water damage).

### NOTE:

Heat trace ALL water pipe and fittings located outside home (attic, crawl space) or building structure. (ALL water pipe and fittings shown above the dashed line in the drawing.)

### NOTE:

ALL pipe and fittings shown below dashed line should be located inside home or building structure.

The vacuum breaker line should be located inside the building structure.

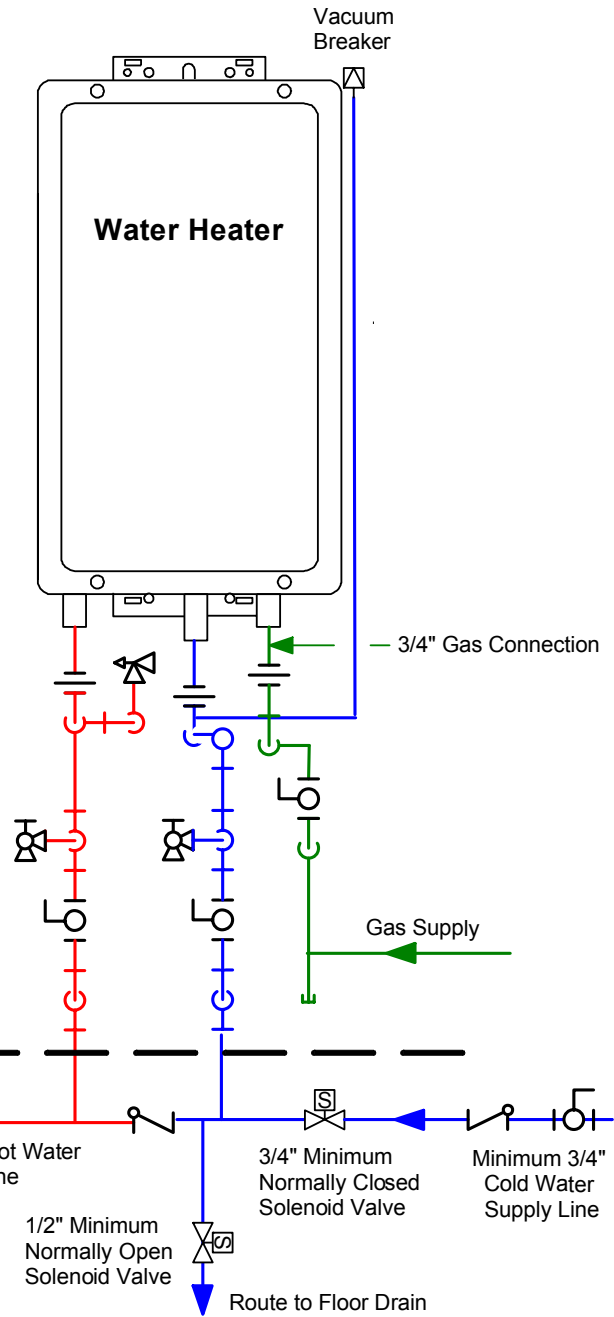

### KEY

	3/4" Ball Valve		Pressure Regulator
	3/4" Union		Circulating Pump
	Check Valve		Boiler Drain Valve
	Pressure Relief Valve		Solenoid Valve

This is not an engineered drawing. It is intended only as a guide and not as a replacement for professionally engineered project drawings. This drawing is not intended to describe a complete system. It is up to the contractor/engineer to determine the necessary components and configuration of the particular system being installed. This drawing does not imply compliance with local building code requirements. It is the responsibility of the contractor/engineer to ensure installation is in accordance with all local building codes. Confer with local building officials before installation.

## Recommended Piping for Basic Installation

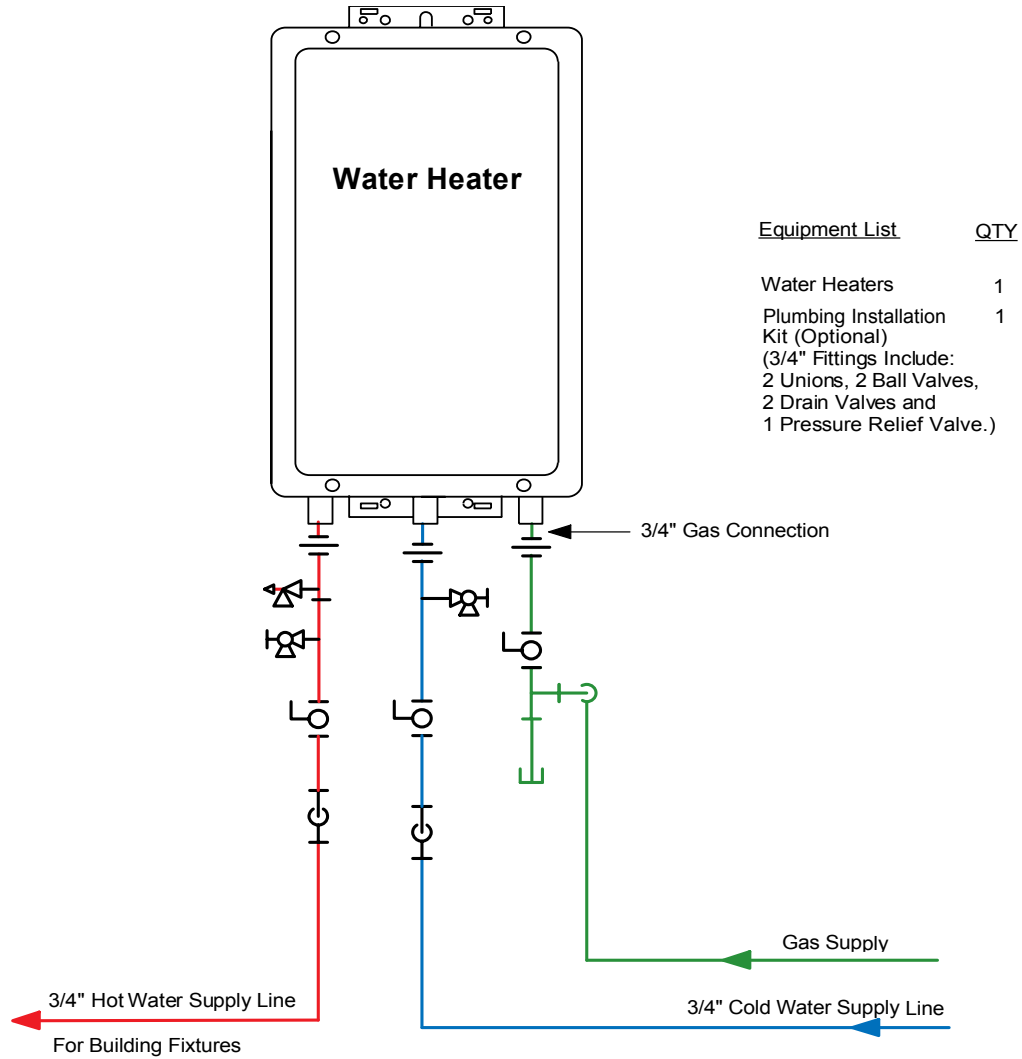

### KEY

	3/4\" Ball Valve		Pressure Regulator
	3/4\" Union		Circulating Pump
	Check Valve		Boiler Drain Valve
	Pressure Relief Valve		Solenoid Valve

This is not an engineered drawing. It is intended only as a guide and not as a replacement for professionally engineered project drawings. This drawing is not intended to describe a complete system. It is up to the contractor/engineer to determine the necessary components and configuration of the particular system being installed. This drawing does not imply compliance with local building code requirements. It is the responsibility of the contractor/engineer to ensure installation is in accordance with all local building codes. Confer with local building officials before installation.

# Recommended Piping for Circulation Systems

**NOTE:**

For residential and commercial applications, this piping arrangement maintains full warranty.

**For this application:**

Pump should be controlled by an Aquastat, Timer or Combination Aquastat and Timer.

Pump to be sized to maintain circulation loop temperature.

The pump should be sized to overcome the pressure loss through the tank water heater, and supply and return plumbing.

Pump to be of bronze or stainless construction.

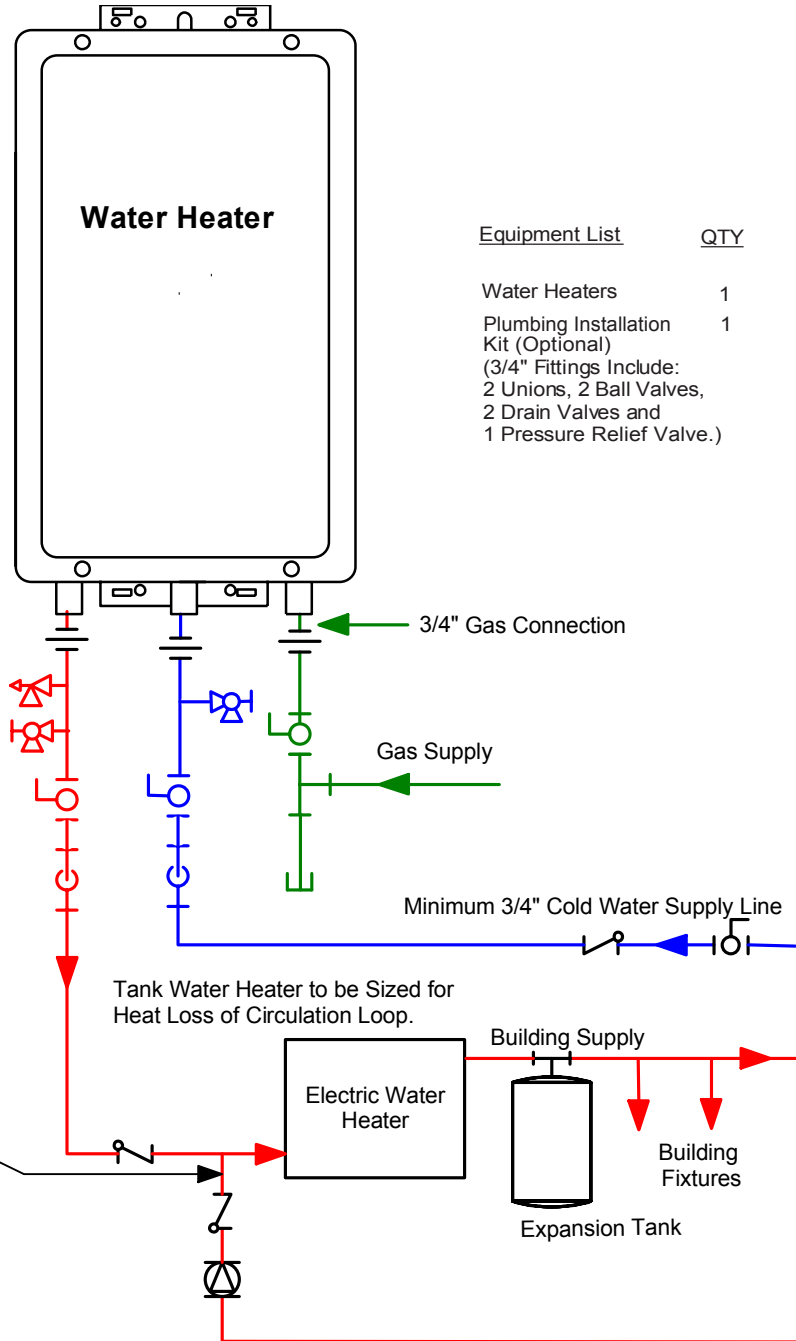

**IMPORTANT:** Connect the building return line to the hot water supply line as close as possible to the water heater.

**KEY**

	3/4" Ball Valve		Pressure Regulator
	3/4" Union		Circulating Pump
	Check Valve		Boiler Drain Valve
	Pressure Relief Valve		Solenoid Valve

This is not an engineered drawing. It is intended only as a guide and not as a replacement for professionally engineered project drawings. This drawing is not intended to describe a complete system. It is up to the contractor/engineer to determine the necessary components and configuration of the particular system being installed. This drawing does not imply compliance with local building code requirements. It is the responsibility of the contractor/engineer to ensure installation is in accordance with all local building codes. Confer with local building officials before installation.

# Optional Piping for Circulation Systems

**NOTE:**

For residential and commercial applications, this piping arrangement reduces the warranty to the following:

- 3 years on heat exchanger
- 3 year on parts

Full warranty will be maintained if an on-demand recirculation system is incorporated. Refer to the Limited Warranty.

**For this application:**

Pump should be controlled by an Aquastat, Timer or Combination Aquastat and Timer.

Pump to be sized to maintain circulation loop temperature.

A minimum of 3 GPM flow is recommended for the circulation system.

The pump should be sized to overcome the pressure loss through the water heater, supply and return plumbing.

Pump to be of bronze or stainless construction.

**Note:** Water heater outlet temperature cannot be adjusted when circulation pump is running.

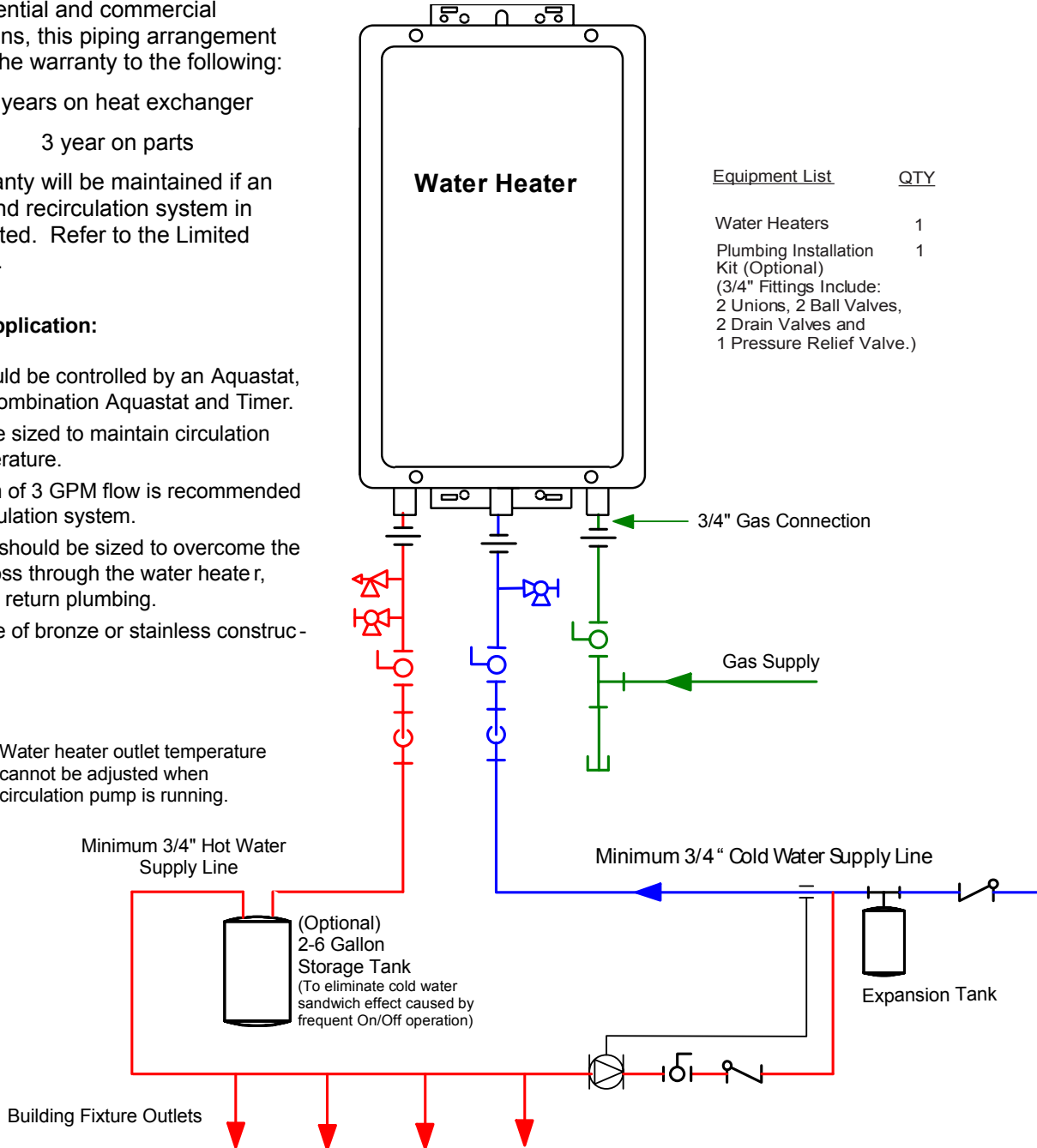

Equipment List	QTY
Water Heaters	1
Plumbing Installation Kit (Optional)	1
(3/4" Fittings Include: 2 Unions, 2 Ball Valves, 2 Drain Valves and 1 Pressure Relief Valve.)	

**KEY**

	3/4" Ball Valve		Pressure Regulator
	3/4" Union		Circulating Pump
	Check Valve		Boiler Drain Valve
	Pressure Relief Valve		Solenoid Valve

This is not an engineered drawing. It is intended only as a guide and not as a replacement for professionally engineered project drawings. This drawing is not intended to describe a complete system. It is up to the contractor/engineer to determine the necessary components and configuration of the particular system being installed. This drawing does not imply compliance with local building code requirements. It is the responsibility of the contractor/engineer to ensure installation is in accordance with all local building codes. Confer with local building officials before installation.

# Flue Terminal Clearances (ANS Z21.10.3 • CSA 4.3)

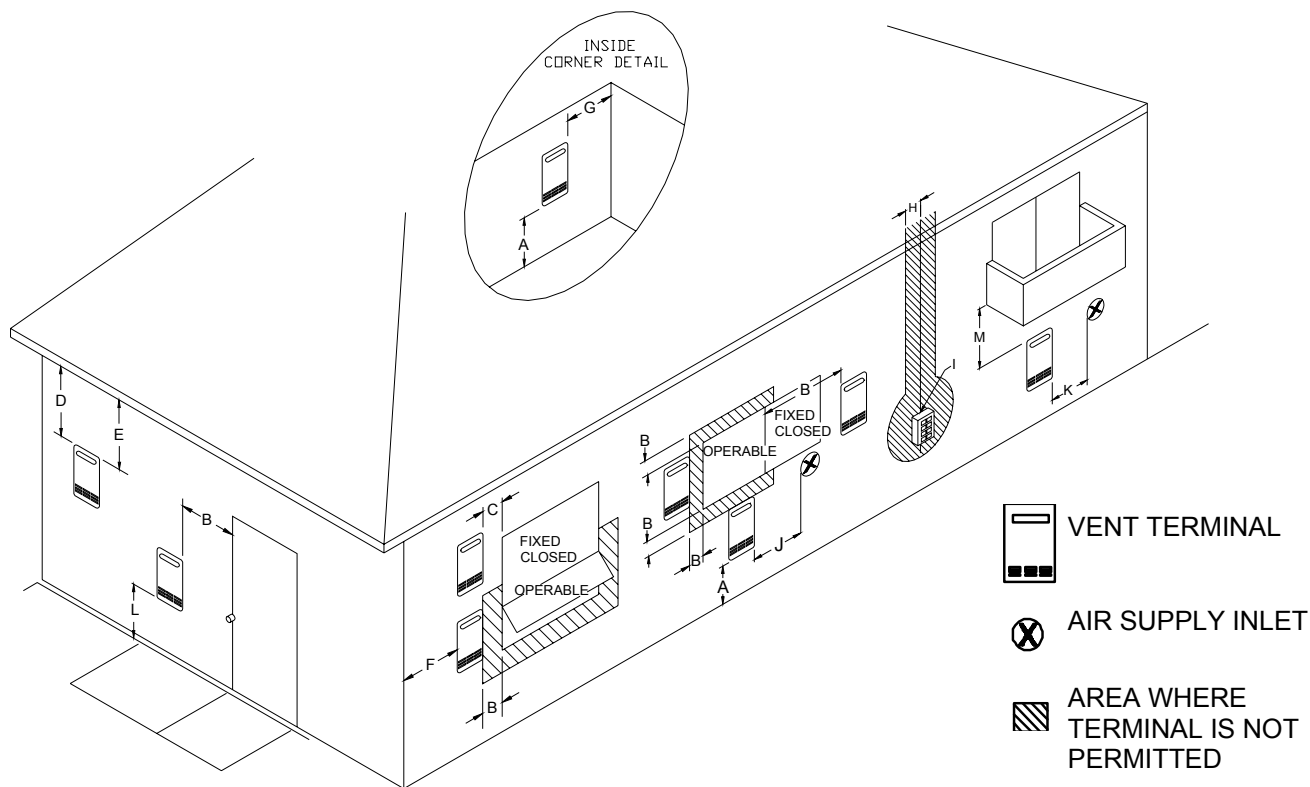

Ref	Description	US Installations
A	Clearance above grade, veranda, porch, deck, or balcony	12 inches (30 cm)
B	Clearance to window or door that may be opened	12 inches (30 cm)
C	Clearance to permanently closed window	*
D	Vertical clearance to ventilated soffit, located above the terminal within a horizontal distance of 2 feet (61 cm) from the center line of the terminal	*
E	Clearance to unventilated soffit	*
F	Clearance to outside corner	*
G	Clearance to inside corner	*
H	Clearance to each side of center line extended above meter/regulator assembly	*
I	Clearance to service regulator vent outlet	*
J	Clearance to nonmechanical air supply inlet to building or the combustion air inlet to any other appliance	12 inches (30 cm)
K	Clearance to a mechanical air supply inlet	3 feet (91 cm) above if within 10 feet (3 m) horizontally
L	Clearance above paved sidewalk or paved driveway located on public property	*
M	Clearance under veranda, porch, deck, or balcony	*

- ① A vent shall not terminate directly above a sidewalk or paved driveway that is located between two single family dwellings and serves both dwellings.
- ② Permitted only if veranda, porch, deck, or balcony is fully open on a minimum of two sides beneath the floor.
- \* For clearances not specified in *ANSI Z223.1/NFPA 54* or *CSA B149.1*, clearances are in accordance with local installation codes and the requirements of the gas supplier.

## Additional Clearances

---

Local codes supersede these clearances.

- Avoid termination locations near a dryer vent.
- Avoid termination locations near commercial cooking exhaust.

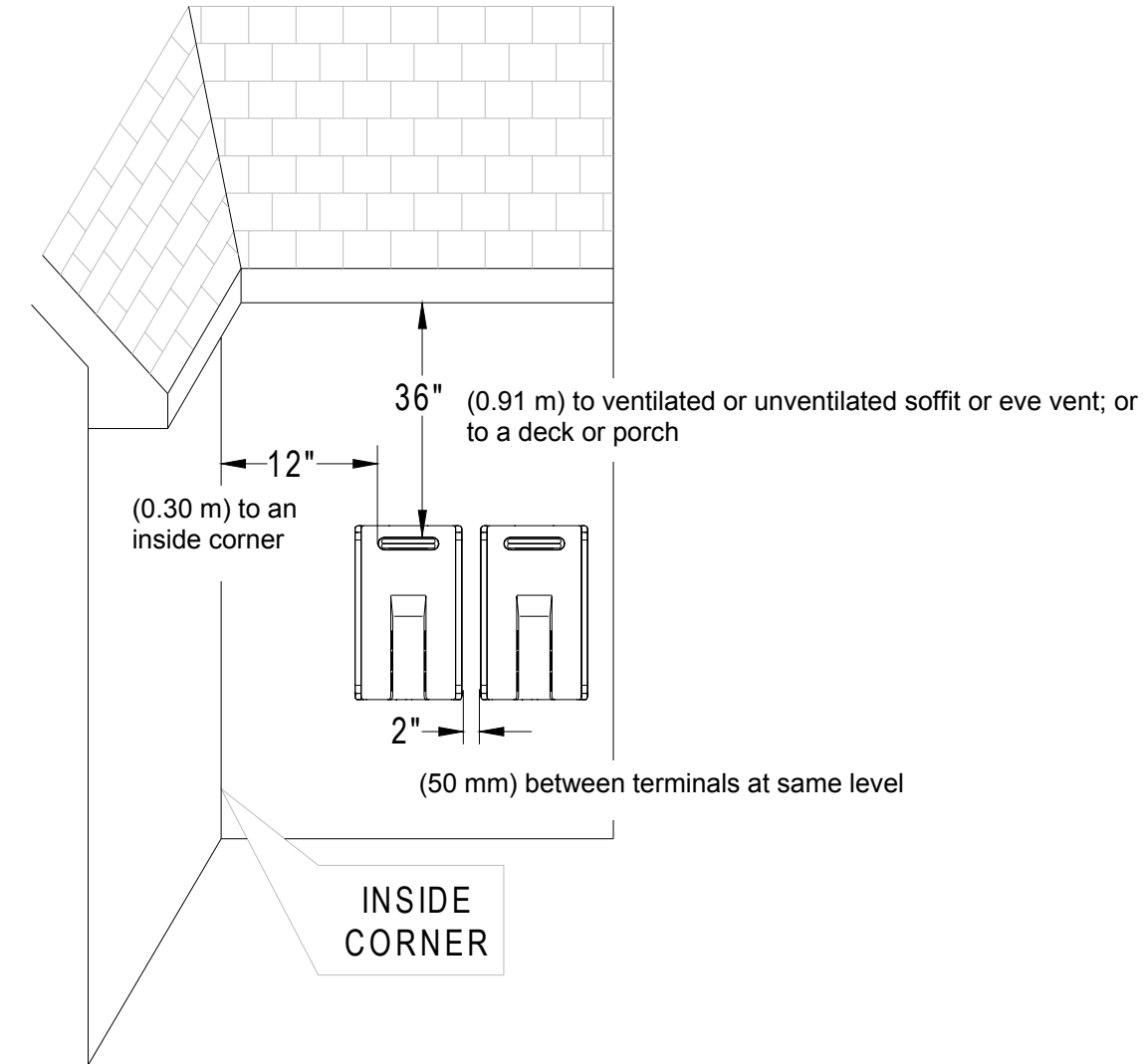

## High Altitude Installations

Set dip switches 2 and 3 to the values shown in table below for your altitude. The default setting for the appliance is 0-2000 ft (0-610 m) with switches No. 2 and No. 3 in the OFF position.

**WARNING** DO NOT adjust the other dip switches unless specifically instructed to do so.

	0-2000 ft (0-610 m)	2001-5200 ft (610-1585 m)	5201-7700 ft (1585-2347 m)	7701-10200 ft (2347-3109 m)
Switch No. 2	OFF	OFF	ON	ON
Switch No. 3	OFF	ON	OFF	ON

Switch No.	Switch No.	Switch No.	Switch No.

## Connecting Multiple Water Heaters

The 2-Unit connection cable is an optional accessory that connects 2 water heaters and allows them to function as one hot water source.

The Multi-Unit connection kit and Multi-Unit connection cables are optional accessories that connect 2 to 5 water heaters and allow them to function as one hot water source.

The Multi-Unit connection kit includes a PC board and one Multi-Unit connection cable.

Refer to the instructions that come with the accessory for complete installation information.

### Guidelines

- Do not install both the 2-Unit connection cable and the Multi-Unit connection kit because they are not designed to operate together.
- Water heaters should be installed less than 18 inches apart so that the cables will reach between units and to prevent temperature fluctuations (cold water sandwich effect) when the water is shut off and turned back on.
- Temperature settings can only be changed on the controller for the primary unit.

Number of Connected Water Heaters:	Accessories Necessary:
2	(1) 2-Unit connection cable OR (1) Multi-Unit connection kit
3	(1) Multi-Unit connection kit and (1) Multi-Unit connection cable
4	(1) Multi-Unit connection kit and (2) Multi-Unit connection cables
5	(1) Multi-Unit connection kit and (3) Multi-Unit connection cables



## Temperature Controller Installation

---

### Location

- The controller should be out of reach of small children.
- Avoid locations where the controller may become hot (near the oven or radiant heater).
- Avoid locations in direct sunlight. The digital display may be difficult to read in direct sunlight.
- Avoid locations where the temperature controller could be splashed with liquids.
- Do not install in locations where it can be adjusted by the public.

---

### Configurations

A maximum of 4 temperature controllers can be installed for a water heater or bank of water heaters. Controllers can only be wired in parallel. Controllers cannot be wired in series.

If 4 temperature controllers are installed, simultaneously press the Priority and On/Off buttons on the fourth controller until a beep sounds.

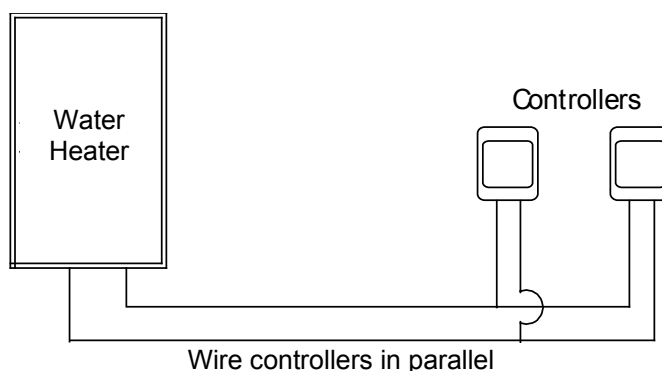

---

### Cable Lengths and Size

The cable for the temperature controller should be a non-polarized two-core cable with a minimum gauge of 22 AWG. The maximum cable length from each controller to the water heater depends on the total number of wired controllers connected to the water heater.

Number of Wired Controllers	Maximum Cable Length for each Controller to Water Heater
1	328 ft (100 m)
2	164 ft (50 m)
3 or 4	65 ft (20 m)

## Temperature Controller Installation

### Mounting the Controller

Follow the procedure below to install additional controllers.

1. Determine a suitable location for the controller.
2. Make three holes in the wall as shown.
3. Run the cable between the controller and the water heater or the controller and the other controller.
4. Remove the face plate from the temperature controller using a screwdriver.
5. Connect the cable to the temperature controller.
6. Mount the controller to the wall using the holes drilled in step 2.
7. Disconnect the power from the water heater.
8. Remove the cover of the water heater.
9. Remove the plastic cover from the PCB and electrical connections.
10. Thread the cable through the access hole at the base of the unit and connect the wires to the controller terminals on the right hand side bottom of the PCB.
11. Secure the controller cable using the clamp provided.
12. Replace plastic cover over PCB and then replace the cover of the water heater.

### WARNING

Do not attempt to connect the temperature controllers with the power on. There is 120 volt potential, next to the temperature controller connections inside the unit.

**Do not connect the temperature controller to the 120VAC terminals provided for the optional solenoid drain valves.**

All service and wiring should be performed by a registered installer.

Outline of Controller

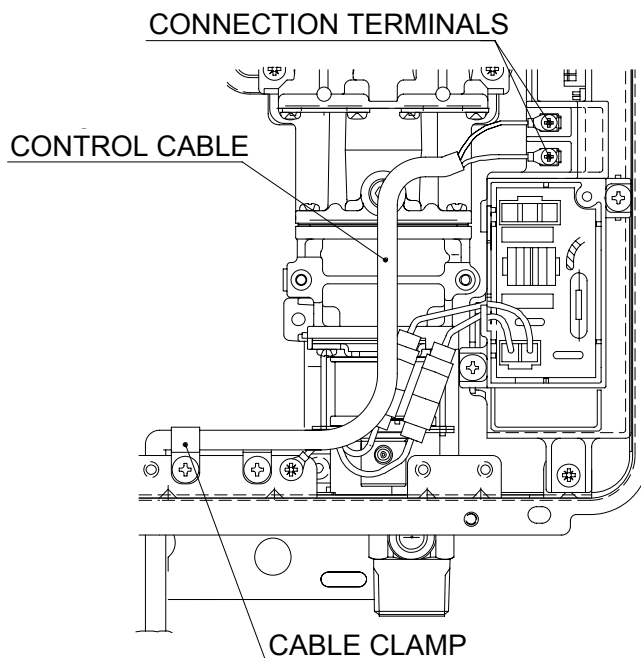
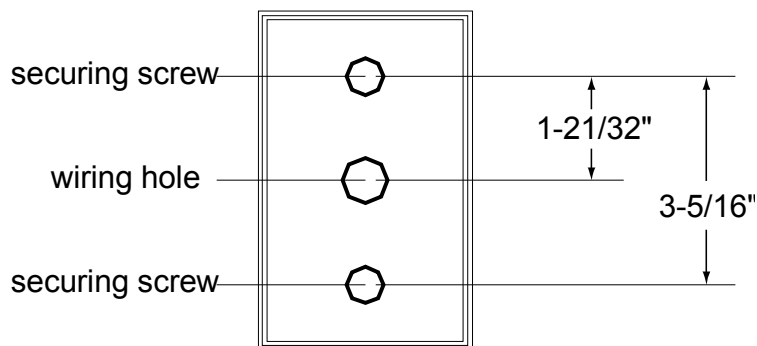



FOR YOUR SAFETY READ BEFORE OPERATING

**WARNING** If you do not follow these instructions exactly, a fire or explosion may result causing property damage, personal injury or loss of life.

- A. This appliance does not have a pilot. It is equipped with an ignition device which automatically lights the burner. Do not try to light the burner by hand.
- B. BEFORE OPERATING smell all around the appliance area for gas. Be sure to smell next to the floor because some gas is heavier than air and will settle on the floor.  
**WHAT TO DO IF YOU SMELL GAS**
  - Do not try to light any appliance.
  - Do not touch any electric switch; do not use any phone in your building.
  - Immediately call your gas supplier from a neighbor's phone. Follow the gas supplier's instructions.
- If you cannot reach your gas supplier, call the fire department.
- C. Use only your hand to push in or turn the gas control knob. Never use tools. If the knob will not push in or turn by hand, do not try to repair it, call a qualified service technician. Force or attempted repair may result in a fire or explosion.
- D. Do not use this appliance if any part has been under water. Immediately call a qualified service technician to inspect the appliance and to replace any part of the control system and any gas control which has been under water.

OPERATING INSTRUCTIONS

1. **STOP!** Read the safety information above.
2. Set the thermostat to lowest setting.
3. Turn off all electric power to the appliance using the ON/OFF button.
4. This appliance is equipped with an ignition device which automatically lights the burner. Do not try to light the burner by hand.
5. Locate the manual gas valve on the side of the heater. Turn the manual valve clockwise to the full OFF position. 
6. Wait five (5) minutes to clear out any gas. Then smell for gas, including near the floor. If you smell gas, STOP! Follow "B" in the safety information above. If you don't smell gas, go to the next step.
7. Turn the manual gas valve counterclockwise to the full ON position. 
8. Turn on all electric power to the appliance using the ON/OFF button.
9. Set the thermostat to desired setting.
10. Open a hot water tap. If the appliance will not operate, follow the instructions "To Turn Off Gas To Appliance" and call your service technician or gas supplier. See manual for additional information.

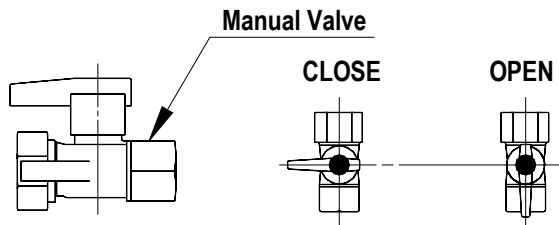

TO TURN OFF GAS TO APPLIANCE

1. Turn off all electric power to the appliance using the ON/OFF button.
2. Set the thermostat to lowest setting.
3. Locate the manual gas valve on the side of the heater. Turn the manual valve clockwise to the full OFF position. 

# Technical Data

## Pressure Drop Curve

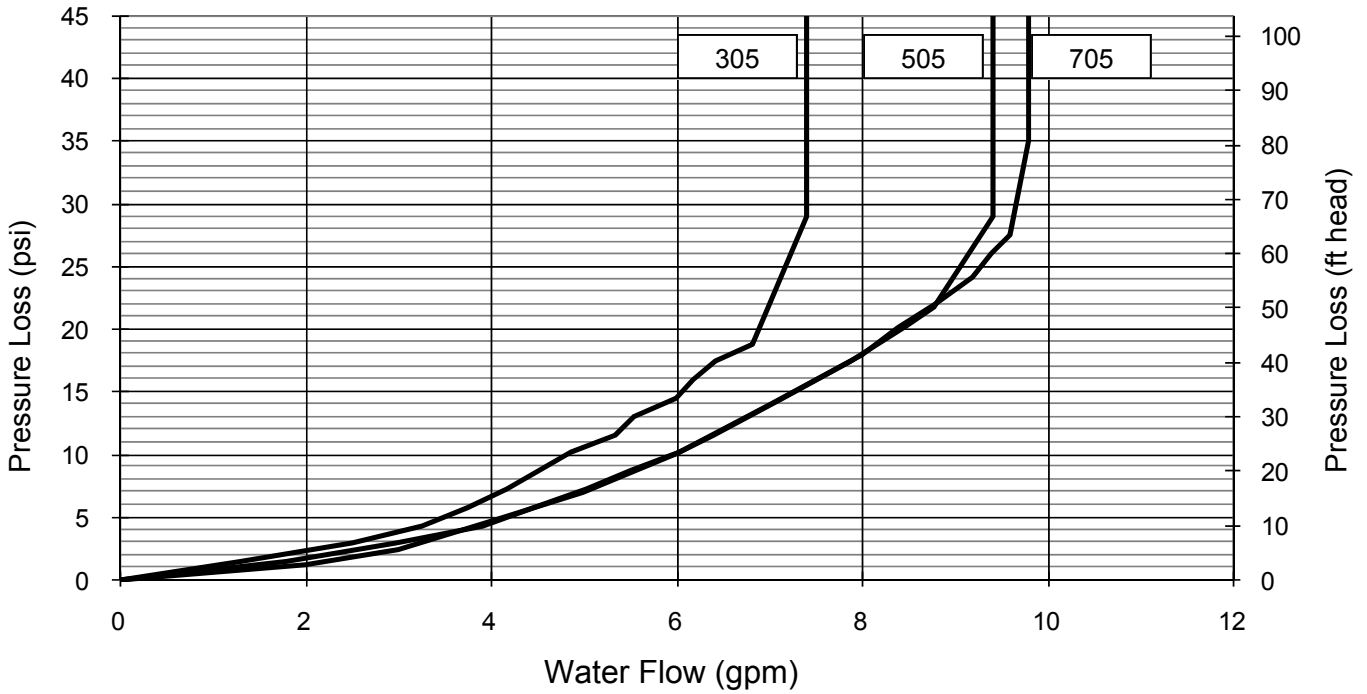

## Outlet Flow Data

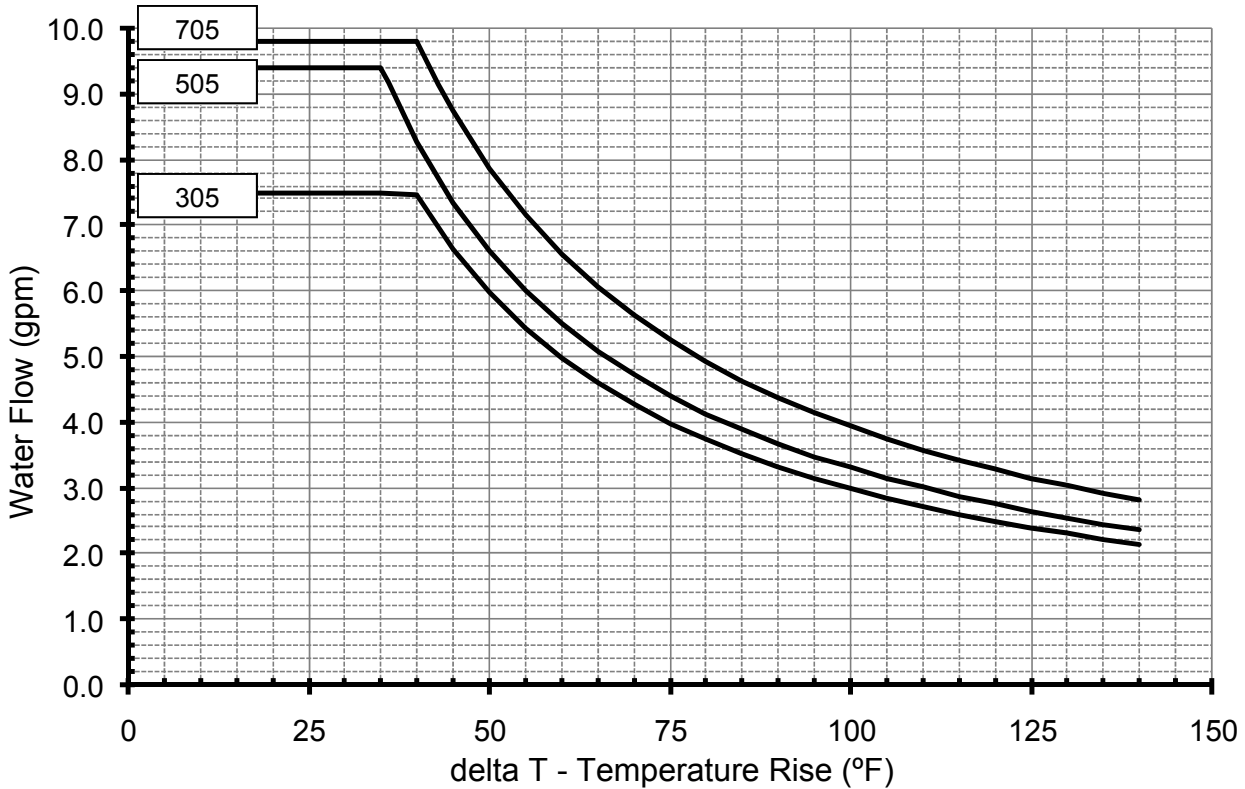

## Space Heating

---

If the water heater is to be used for both water (potable) heating and space heating then the following apply.

- The piping and components connected to the water heater shall be suitable for use with potable water.
- Toxic chemicals, such as used for boiler treatment, shall not be introduced into the potable water.
- The water heater shall not be connected to any heating system or components previously used with a nonpotable water heating appliance.
- When the system requires water for space heating at temperatures higher than required for other uses, a means such as a mixing valve shall be installed to temper the water for other uses in order to reduce the scald hazard potential.

Space heating applications are considered commercial applications for warranty purposes.

### **Temperature Setting**

When using this appliance to provide domestic hot water it is recommended that the domestic hot water temperature be reduced to acceptable temperatures in accordance with local codes. In the absence of local codes it is recommended that the domestic hot water temperature be set to 140° F (60° C) or lower in accordance with UPC 501.6 by using mixing valves or the temperature controller for the water heater.

### **Pumps**

Only use pumps of brass or stainless steel construction. Do not use pumps of iron construction as they will oxidize and clog the inlet filter on the appliance.

Pumps circulating water through the water heater must be sized to overcome the pressure loss through the water heater, the heating system, and any additional plumbing pressure losses. The pressure drop curve based on the water heater model is provided in this manual.

### **Replacement**

When replacing an existing space heating application's water heating source (boiler, tank water heater, tankless water heater, etc.) with these water heaters, ensure that the water heaters are sized to adequately provide the necessary BTU input for the desired space heating application. These water heaters are designed to maintain a constant outlet temperature and will supply only the necessary amount of BTU's to maintain that temperature. Depending on the application the maximum BTU rating of the unit may not be achieved.

### **Iron Components**

Do not use these water heaters directly for space heating applications involving iron radiators or applications with any iron components. Iron components may oxidize creating rust that will clog the inlet filter of the water heater.

# Dimensions

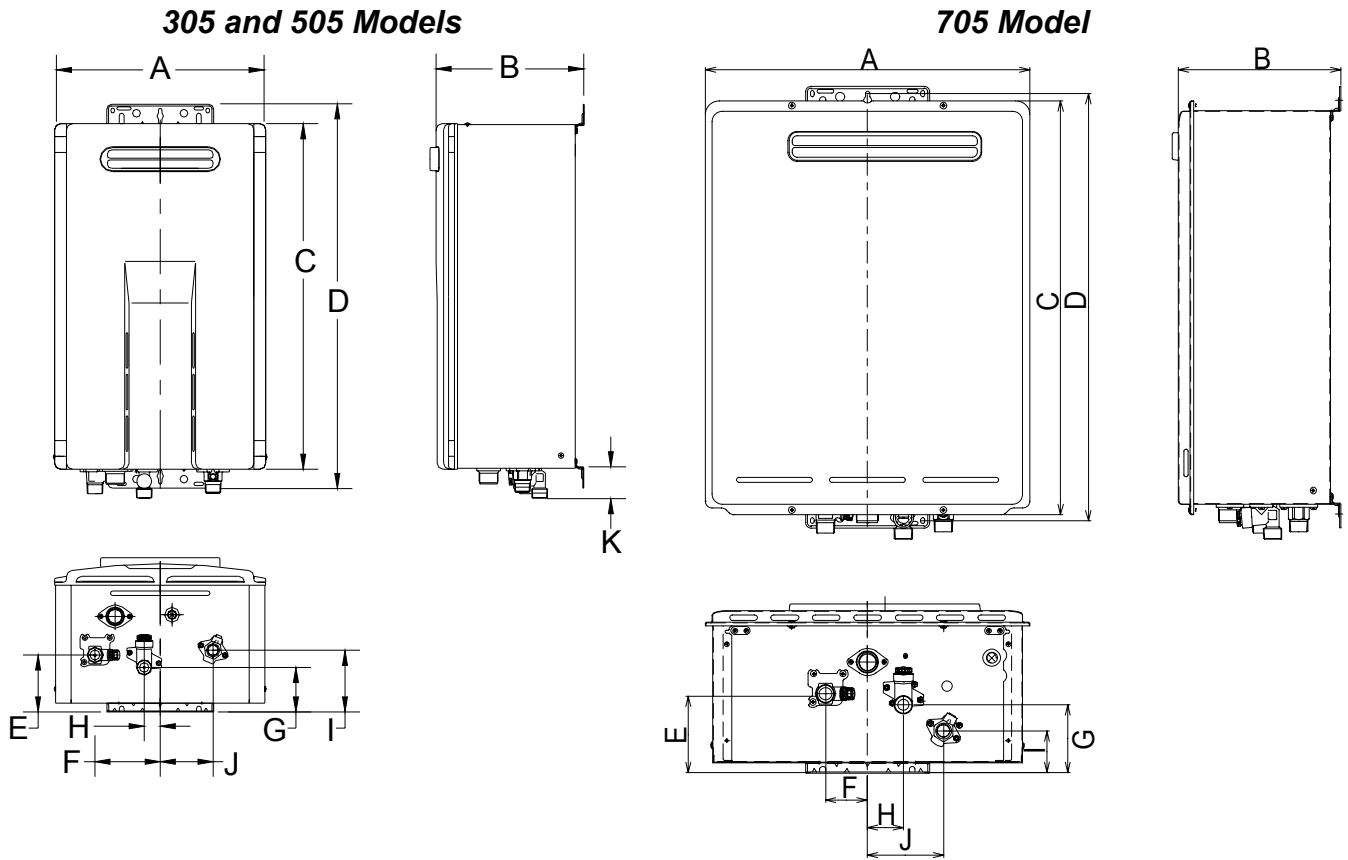

DIM	DESCRIPTION	305, 505 in (mm)	705 in (mm)
A	Width	14 (355.6)	18.5 (470)
B	Depth	9.8 (249.5)	9.3 (235.5)
C	Height - Unit	22.9 (582)	23.6 (600)
D	Height - with brackets	25.4 (646.4)	25.2 (640)
E	Hot Water Outlet - from wall	3.8 (96)	4.5 (115)
F	Hot Water Outlet - from center	4.3 (110)	2.4 (61)
G	Cold Water Inlet - from wall	3.0 (75)	3.9 (99)
H	Cold Water Inlet - from center	1.1 (27)	2.0 (52)
I	Gas Connection - from wall	4.1 (104)	2.4 (61.2)
J	Gas Connection - from center	3.5 (89)	4.3 (110)
K	From base to gas connection	1.6 (40)	1.6 (40)
	From base to cold connection	2.0 (50)	2.0 (50)
	From base to hot connection	1.6 (41)	1.6 (41)

# Ladder Diagram

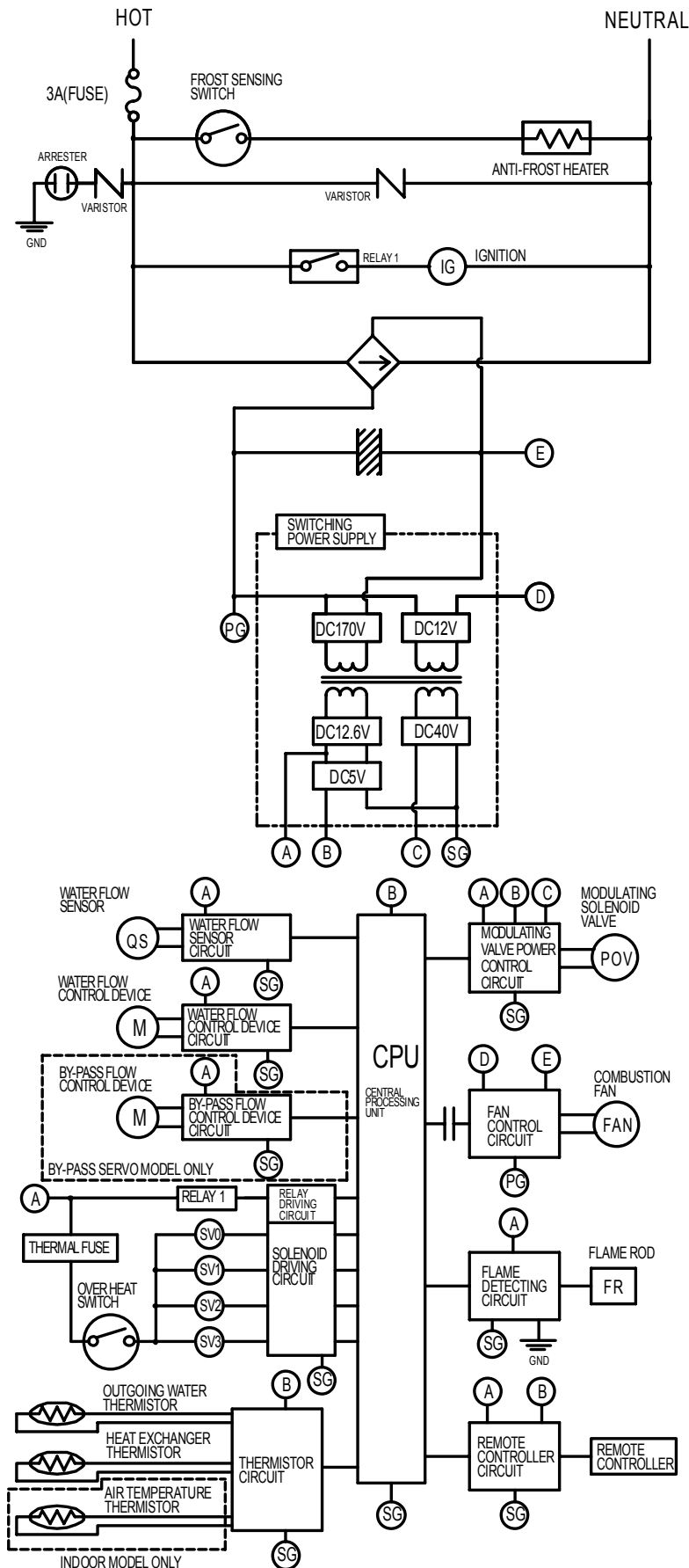

# Warranty

## What is covered?

This Warranty covers any defects in materials or workmanship when the product is installed and operated according to written installation instructions, subject to the terms within this Limited Warranty document. This Warranty applies only to products that are installed by a factory authorized or licensed contractor. Improper installation may void this Warranty. It is strongly suggested that you use a factory authorized or licensed installer who has attended a product knowledge class before installing this water heater. This Warranty extends to the original purchaser, but only while the product remains at the site of the original installation. This Warranty only extends through the first installation of the product and terminates if the product is moved or reinstalled at a new location.

## How long does coverage last?

Item	Period of Coverage (from date of purchase)	
	Residential Applications	Commercial Applications including radiant heating
Heat Exchanger	12 years *	5 years *
All Other Parts and Components	5 years *	5 years *
Reasonable Labor	1 year	

\* Note: Period of coverage is reduced to 3 years from date of purchase when used as a circulating water heater within a hot water circulation loop, where the water heater is in series with a circulation system and all circulating water flows through the water heater, and where an on-demand recirculation system is not incorporated.

On-demand recirculation is defined as a hot water recirculating loop or system that utilizes existing hot and cold lines or a dedicated return line, and only activates when hot water is used. It can be activated by a push button, motion sensor, or voice activation but not by a temperature sensor. A timer added to a standard recirculating pump is not considered as on-demand.

There is no warranty coverage on product installed in a closed loop application, commonly associated with space heating only applications.

Use of an commercial controller in a residential dwelling will reduce the warranty coverage to that of a commercial warranty application.

The integrated controller on indoor models has a 1 year warranty on parts.

## What will be done?

Repair or replacement of the covered product or any part or component that is defective in materials or workmanship as set forth as follows. Payment of reasonable labor charges associated with the repair or replacement of any such part or component. All repair parts must be genuine OEM parts. All repairs or replacements must be performed by an individual or servicing company that is properly trained, factory authorized or licensed to do the type of repair.

Replacement of the product may be authorized by the manufacturer only. The manufacturer does not authorize any person or company to assume for it any obligation or liability in connection with the replacement of the product. If it is determined that repair of a product is not possible, the product will be replaced with a comparable product, at the manufacturer's discretion. If a component or product returned to the manufacturer is found to be free of defects in material or workmanship, or damaged by improper installation or damaged during return shipping, the warranty claim for product, parts and labor may be denied.



# Warranty

## How do I get service?

You must contact a factory authorized/licensed contractor or authorized service provider for the repair of a product under this Warranty. For the name of a qualified/authorized service provider please contact your place of purchase, call 1-866-677-4960 or write to 500 Tennessee Waltz Parkway, Ashland City, TN 37015.

Proof of purchase is required to obtain warranty service. You may show proof of purchase with a dated sales receipt.

## What is not covered?

This Warranty does not cover any failures or operating difficulties due to the following:

- accident, abuse, or misuse
- alteration
- misapplication
- force majeure
- improper installation (such as but not limited to inadequate water quality, condensate damage, improper venting, incorrect gas type, incorrect gas or water pressure, or absence of a drain pan under the appliance)
- improper maintenance (such as but not limited to scale buildup, freeze damage, or vent blockage)
- incorrect sizing
- any other causes other than defects in materials or workmanship

This Warranty does not apply to any product whose serial number or manufacture date has been defaced. This Warranty does not cover any product used in an application that uses chemically treated water such as a pool or spa heater. This appliance is suitable for filling large or whirlpool bath tubs with potable water. Refer to the Water Quality Section in the Operation and Installation Manual.

No one is authorized to make any other warranties on behalf of the manufacturer. Except as expressly provided herein, there are no other warranties, expressed or implied, including, but not limited to warranties of merchantability or fitness for a particular purpose, which extend beyond the description of the warranty herein and further the manufacturer shall not be liable for indirect, incidental, special, consequential or other similar damages that may arise, including lost profits, damage to person or property, loss of use, inconvenience, or liability arising from improper installation, service or use. Some states do not allow the exclusion or limitation of incidental or consequential damages, so the above limitation may not apply to you.

## Limitation on implied warranties

Any implied warranties of merchantability and fitness arising under state law are limited in duration to the period of coverage provided by this limited Warranty, unless the period provided by state law is less. Some states do not allow limitations on how long an implied Warranty lasts, so the above limitation may not apply to you.

This Warranty gives you specific legal rights, and you may also have other rights which vary from state to state.

# Notes

## Notes



060 00012 39526 6

**U287-1184 (00)**  
Printed in Japan 09.01