

Maintenance sheet

ATM32
63T141

A. Troubleshooting

If the error code is indicated on the 7-Seg LED on the PCB (Part #701) of the water heater (and/or the remote controller), refer to Section B.

<< It takes long time to get hot water at the fixtures >>

- The time it takes to deliver hot water from the water heater to your fixtures depends on the length of piping between the two. The longer the distance or the bigger the pipes, the longer it will take to get hot water.
- If you would like to receive hot water to your fixtures quicker, you may want to consider a hot water recirculation system.

<< The water is not hot enough or turns cold and stays cold >>

- Compare the flow and temperature. Refer to the "Output temperature chart" of the installation manual.
- Check cross plumbing between cold water lines and hot water lines.
- Check if the gas supply valve fully open, the gas line sized properly and the gas supplies pressure enough. Refer to the "Gas supply and gas pipe sizing" of the installation manual.
- Check the set temperature, and change the dipswitch setting. Refer to Section D.
- Refer to "Water circuit" in this section.

<<The water is too hot>>

- Check the set temperature, lower setting temperature.

<<The hot water is not available when a fixture is opened>>

- Refer to the "Power supply circuit" and "Water circuit" in this section.

<<Fluctuation in hot water temperature>>

- Check if the filter on the cold water inlet cleaned. (Part #408)
- Check if the gas line sized properly and the supply gas pressure sufficient.
- Check for cross connection between cold water lines and hot water lines.
- Refer to "Water circuit" in this section.

<<Unit does not ignite when water goes through the water heater>>

- Refer to the "Power supply circuit" and "Water circuit" in this section.
- If you use the remote controller, turn the power button on and then the green LED will light up.
- Check if the filter on the cold water inlet cleaned. (Part #408)

<<The fan motor still spinning after operation has stopped>>

- This is normal. After operation has stopped, the fan motor keeps running for 35 seconds in order to re-ignite quickly, as well as purge all the exhaust gas out of the flue.

<<Abnormal sound from water heater>>

- An abnormal sound from the water heaters is caused by not enough air supply or wrong installations. The water heater needs more combustion air. Refer to the "101" error code in the Section B.

<<Power supply circuit>>

1. If the remote controller installed, press the "ON/OFF" button of the remote controller, and make sure that the green LED on the "ON/OFF" button of the remote controller is lit. Restart the water heater.
2. Check if that the 7-Seg LED on the PCB (Part #701) of the water heater is lit. If so, the power supply circuit of the water heater is under normal condition. Next, refer to the "Water circuit" in this section.
3. Check the fuse on the surge box (Part #715), and if it has a brown spot, need to replace it.
4. Check the power supply, and make sure that the water heater has 120 VAC.
5. If the 7-Seg LED on the PCB (Part #701) isn't lit, some electrical parts can be broken. **Consult the manufacturer.**

<<Water circuit>>

1. If you set the remote controller, turn the power button on and then the green LED will light up.
2. Open all hot water faucets, and make sure that there is enough water flow. This water heater needs at least 0.5 GPM water flow to operate.
3. Check for reverse connection and cross connection.
4. Check if the filter on the cold water inlet cleaned. (Part #408)
5. Check if there is no debris or obstruction on the fixtures.
6. Check if water ways in the water heater are frozen. If so, unfreeze them. And refer to installation manual to protect your water heater from freeze.
7. Check if the inlet water pressure is higher than 40 psi. And if it's lower than 40 psi, need to increase the pressure.
8. Check for connections and breakage of wires (Part #423, 429).
9. Check if the motor drive of the water control valve (Part #423) is locked due to scale buildup, and/or water leakage. **Consult the manufacturer.**

C. Wiring Diagram and check point of the Water heater

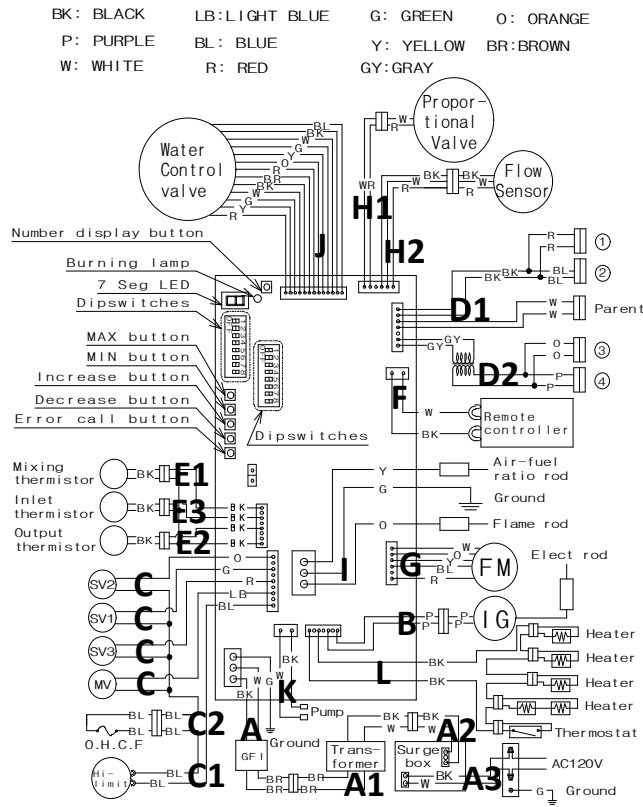

Appendix B (For error code 611 and 621)

Refer check point "G" in the diagram to the left and followings.

- Check voltage between red wire and blue wire. (Normal: DC 110 to 160 V)
- Check voltage between yellow wire and blue wire. (Normal: DC 13 to 17 V)
- Check voltage between orange wire and blue wire (Normal: DC 2.0 to 6.5 V)

All check points are normal?
Yes >> Replace the fan motor. (Part #115)
No >> Replace the PCB. (Part #701)

Appendix C (For error code 510 and 551)

Refer check point "C" in the diagram to the left and followings.

Check voltage on the each valve on the gas valves assembly.

- Between blue wire and light blue wire (#3). (Normal: DC 78 to 100 V)
- Between blue wire and green wire. (#9). (Normal: DC 78 to 100 V)
- Between blue wire and orange wire (#53). (Normal: DC 78 to 100 V)
- Between blue wire and red wire (#73). (Normal: DC 78 to 100 V)

All check points are normal?
Yes >> Replace the gas valves assembly. (Part #120)
No >> Replace the PCB. (Part #701)

Appendix D (For error code 311, 321, 331, and 941)

- Mixing thermistor (Find the marking of No.113 on the connector) Check point "E1"
- Output thermistor (Find the marking of No.12 on the connector) Check point "E2"
- Inlet thermistor (Find the marking of No.42 on the connector) Check point "E3"

Check resistance between black wire and black wire.

Temperature	°F	50	59	68	77	86	95
	°C	10	15	20	25	30	35
Resistance	kΩ	15.4	12.6	10.3	8.5	7.0	5.9

All check points are normal?
Yes >> Replace the PCB. (Part #701)
No >> Replace the wrong thermistor. (Part #418, 422, 433)

Appendix E (For error code 741)

Refer check point "F" on the wiring diagram above.

Check voltage on the remote controller terminal on the PCB. (Normal: DC 11 to 25 V)

This check point is normal?
Yes >> Replace the remote controller.
No >> Replace the PCB. (Part #701)

Appendix F (For error code 651 and 661)

Refer check point "J" on the wiring diagram above.

Check voltage between blue wire and brown wire. (Normal: DC 13 to 16 V)

This check point is normal?
Yes >> Replace the Water control valve. (Part #423)
No >> Replace the PCB. (Part #701)

B. Error codes

031: Incorrect dipswitch setting

- Check the dipswitch settings on the PCB. Refer to Section D.

101: Warning for the "991" error code

- Check the gas type of the water heater. If it's wrong gas type model, replace the water heater to correct one.
- Check if there is any blockage (For example, Damper sticking, Vent Flaps installed on the terminator, Snow build up around terminator, Installed in a closet (No ventilation or lack of combustion air)) in the intake air and/or exhaust. Refer to the "Vent termination clearances" of the installation manual.
- If the water heater is installed as a direct-vent system, check whether there are enough distance between the intake air terminal and the exhaust terminal. Refer to the "Vent termination clearances" of the installation manual.
- Check if the total vent length doesn't exceed 50 ft and the # of elbows is less than 5Ea.
- Check the altitude/elevation of area of where the water heater installed. Refer to the "High-altitude function" of the Section D. And change the dipswitch settings.
- Check if there is grease and/or dirt in the burner (Part #101), and the fan motor (Part #115), especially if the water heater has been installed in a contaminated area.
- Check if there is dust and lint in heat exchanger.
- Check the manifold pressure of the water heater. Refer to installation manual.

111: Ignition failure

1. Check gas supply and inlet gas pressure.
2. Check if the Hi-limit switch (Part #432) is properly functioning.
3. Check for connection/breakage of wires (Part #110, 403, 704, 707, 709), burn marks on the computer board (Part #701), and/or soot on the flame rod (Part #106). And then if O.H.C.F (Part #010, 403) is breakage, **Consult the manufacturer.**
4. Check if there is a buzzing spark ignition sound coming from the burner (Part #101) when water heater prepares for combustion.
5. Listen for the double "clunk" sound coming from the gas valves assembly (Part #120) when water heater goes into combustion.
6. (Only no sparking and/or kick sound) Check voltage on each wire to gas valves assembly (Part #120) and/or the igniter (Part #125). Refer to the "Appendix A" in Section C.
 - *No sparking sound >>>> Refer to the #1 at "Appendix A" in Section C.
 - *No kick sound >>>> Refer to the #2 at "Appendix A" in Section C.
7. Check if there is leaking from heat exchanger (Part #210 or 211)
8. Check if there is dust and lint in nozzles of the manifold (Part #120).
9. Check current on the flame rod (Part #106). Refer to the #3 at "Appendix A" in Section C.

121: Loss of flame

1. Check gas supply and inlet gas pressure.
2. Check if the Hi-limit switch (Part #432) is properly functioning.
3. Check for connection/breakage of wires (Part #110, 403, 704, 707, 709), burn marks on the computer board (Part #701), and/or soot on the flame rod (Part #106). And then if O.H.C.F (Part #010, 403) is breakage, **Consult the manufacturer.**
4. Check if there is leakage from heat exchanger (Part #210 or 211).
5. Check if there is dust and lint in nozzles of the manifold (Part #120).
6. Check current on the flame rod (Part #106). Refer to the #3 at "Appendix A" in Section C.

311,321,331: Disconnected/short-circuited thermistor

- Check for connection/breakage of wires and/or debris on thermistor (Part #418, 422, 433, 705, 706).
- Check thermistor resistance. Refer to the "Appendix D" in Section C.

391: Air-fuel Ratio Rod failure

- Check for connection/breakage of wires (Part #707) and/or soot on the AFR rod. (Part #106).

441: Flow Sensor failure (Only Easy-Link system)

- Check for connection/breakage of wires and/or debris on impeller (Part #429, 705 or 706).

510,551: Abnormal Main and Gas Solenoid Valve

- Check for connection/breakage of wires (Part #704) and/or burn marks on the computer board (Part #701).
- Reset power supply of the water heater.
- Check voltage on the each valve on the gas valves assembly (Part #120). Refer to the "Appendix C" in Section C.

611: Fan motor fault

- Check for connection/breakage of wires, dust buildup in the fan motor (Part #115) and/or burn marks on the computer board (Part #701).
- Check for frozen/corrosion of connectors of the fan motor (Part #115).
- Check voltage between blue wire and each wire of the fan motor (Part #115) during operation. Refer to the "Appendix B" in Section C.

631: Abnormal External Pump

- Check whether the pump connected to PCB (Part #701) works properly.

651,661: Water control valve fault (Only Easy-Link system)

- Check the water control valve (Part #423), connection/breakage of wires (Part #423), motor drive locked due to scale buildup, and/or water leakage.
- Check voltage between black wire and red wire. Refer to the "Appendix F" in Section C.

701: Computer board fault

- Check for connection/breakage of wires (Part #705 or 706) and/or burn marks on the computer board (Part #701).

721: False flame detection

1. Clean the flame rod (Part #106).
2. For indoor models, check if condensate drain is installed on the vent collar of the water heater.
3. Check if there is leaking from heat exchanger (Part #210 or 211).

741: Miscommunication between water heater and remote controller

1. Check the model type of the remote controller. Model No. 9007603005 is the correct one.
2. Inspect for the connections between the water heater and remote controller. Refer to "Remote controller connections" section in the Installation manual.
3. Check the power supply of the water heater.
4. If this error code appears only the 7-Seg LED on the PCB (Part #701), check the voltage on the remote controller terminal on the PCB. Refer to the "Appendix E" in Section C.
5. If this error code appears only remote controller, replace the PCB (Part #701).
6. If this error code appears both the PCB (Part #701) and the remote controller, replace the remote controller.

761: Miscommunication between Parent unit and Child units for Easy-link system

- Check if connection between the parent unit and the child units are correct. Refer to "Easy-Link system" section in the Installation manual.

991: Imperfect combustion

- Refer to the "101" error code in this section.

Appendix A (For error code 111)

Check these points during ignition stage.

- #1. Refer check point "B" on the wiring diagram above. Check voltage between purple wires. (Normal: AC 90 to 110 V)

This check point is normal?

Yes >> Replace the igniter (Part #125)
No >> Go to Next

- #2. Refer check point "C" and "H1" on the wiring diagram above. Check the voltage bellows.

C: Between blue wire and light blue wire (#3). (Normal: DC78 to 100 V)

C: Between blue wire and orange wire (#53). (Normal: DC78 to 100 V)

H1: Check the voltage between white wire and red wire. (Normal: DC 1 to 15 V)

These check points are normal?

Yes >> Replace the gas valves assembly. (Part #120)
No >> Replace the PCB. (Part #701)

- #3. Check current through the orange flame rod wire (Part #707). (Normal: more than 1μA)

This check point is normal during operation?

Yes >> Replace the PCB. (Part #701)
No >> Replace the flame rod. (Part #106)

D. Dipswitch Settings on the computer board of the water heater

Change the dipswitch settings when the power supply is turning off. The dark square is the direction the dipswitch should be set to. DEFAULT is the factory setting.

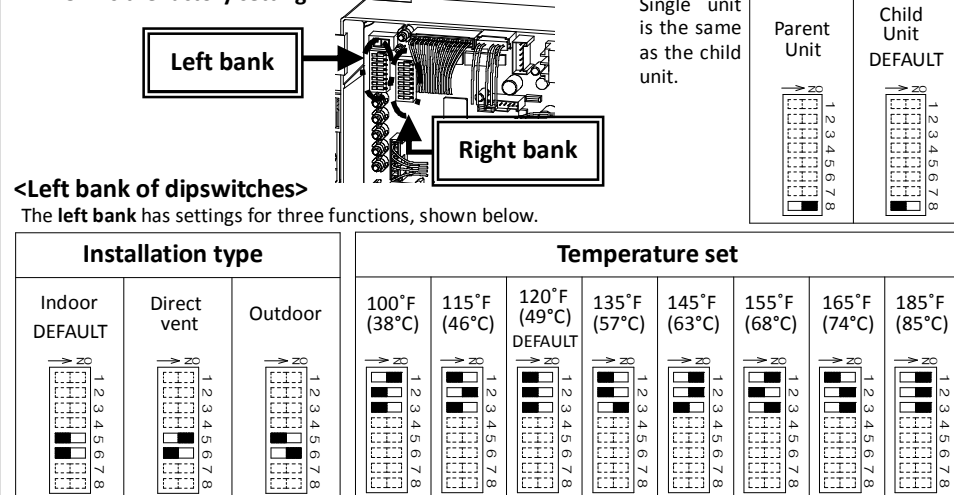

<Left bank of dipswitches>

The left bank has settings for three functions, shown below.

<Right bank of dipswitches>

The right bank has certain special functions and generally **should not need adjustment.**

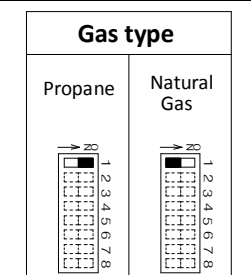

The Gas Type dipswitch should already be properly preset from the factory.

E. Components Diagram / Parts List

Case assembly

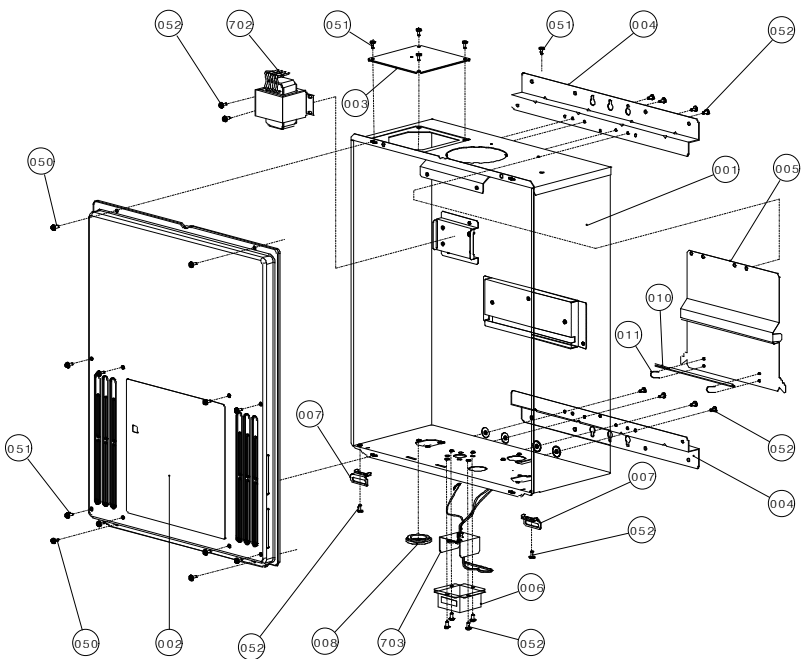

Item#	Part#	Description
001	319143-287	Case assembly
002	319143-303	Front cover
003	319143-285	Air blockage plate
004	319143-225	Bracket
005	319143-283	Back guard panel
006	319143-014	Junction box
007	319143-335	Fixing plate
008	319143-334	Rubber bush
010	319143-016	Overheat-cut-off-fuse for combustion chamber
011	319143-017	Fastener
051	319143-325	Screw M4x10 (W/Washer)
052	319143-026	Screw M4x10 (Coated)
101	319143-299	Burner assembly
102	319143-300	Burner gasket
103	319143-301	Guide plate gasket
104	319143-033	Burner window
105	319143-034	Rod holder gasket
106	319143-035	Flame rod
107	319143-036	Rod holder
108	319143-037	Igniter rod
109	319143-038	Rod cap
110	319143-345	High voltage ignite cable
111	319143-298	Damper
112	319143-346	Urethane tube
113	319143-042	Pressure port
114	319143-281	Fan motor fixing plate
115	319143-043	Fan motor
116	319143-282	Fan damper
117	319143-185	Freeze protection thermostat
118	319143-304	Manifold gasket A
119	319143-336	Manifold gasket B
120	319143-305	Manifold assembly with gas valve assembly LP
	319143-306	Manifold assembly with gas valve assembly NA
121	319143-048	Wire cramp
122	319143-342	Gas inlet ring
123	319143-307	Gas inlet
124	319143-051	Igniter plate
125	319143-052	Igniter
151	319143-059	Pan screw M4x8
152	319143-060	Screw M4x10
153	319143-061	Pan screw M4x12 (W/Washer)
154	319143-330	Screw M3x6
155	319143-327	Screw M3x10
156	319143-351	O-ring P26 NBR (Black)
157	319143-062	Pan screw M4x10
158	319143-325	Screw M4x10 (W/Washer)
159	319143-063	Hex head screw M4x8
160	319143-090	Pan screw M4x6 (W/Waher)

Burner assembly

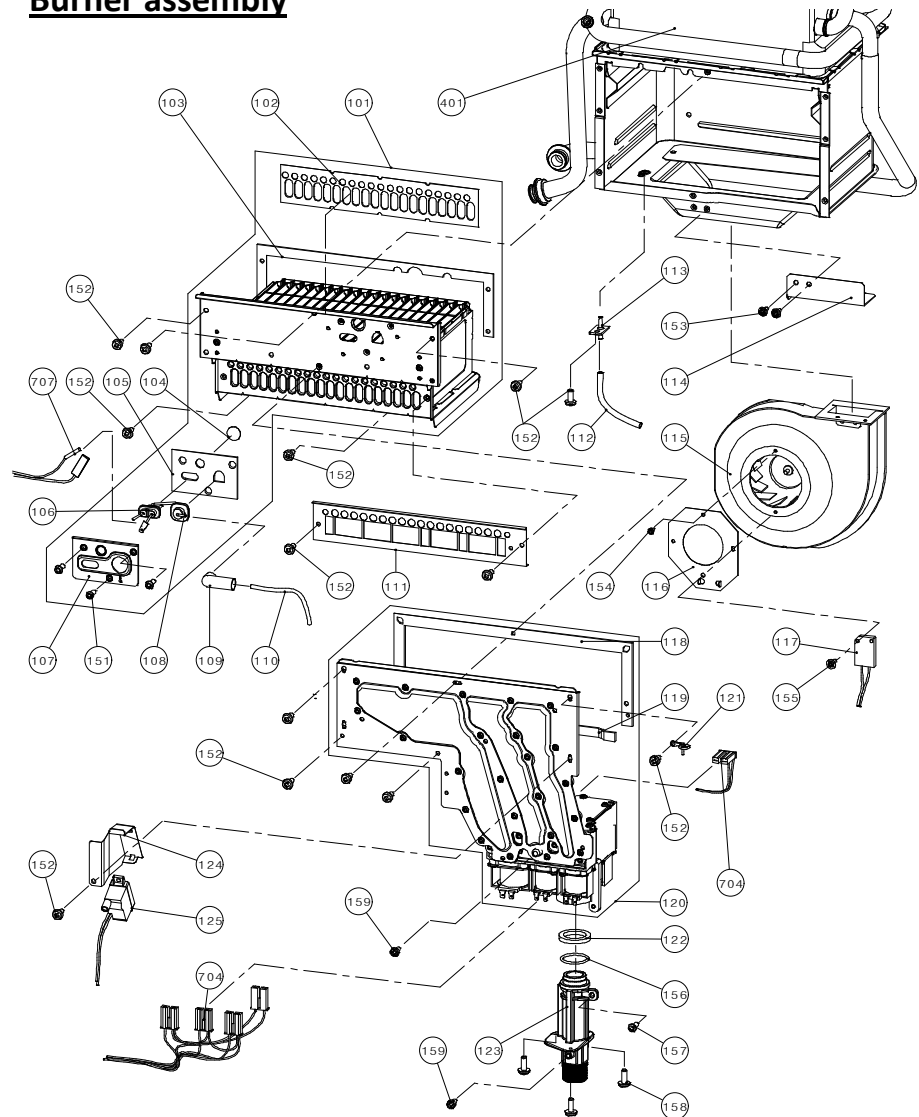

Computer board assembly

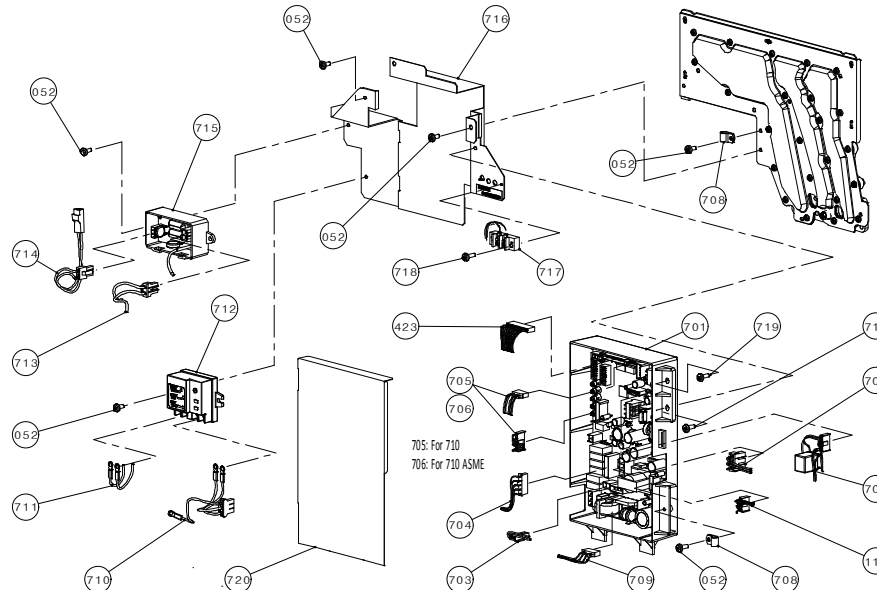

Water way assembly

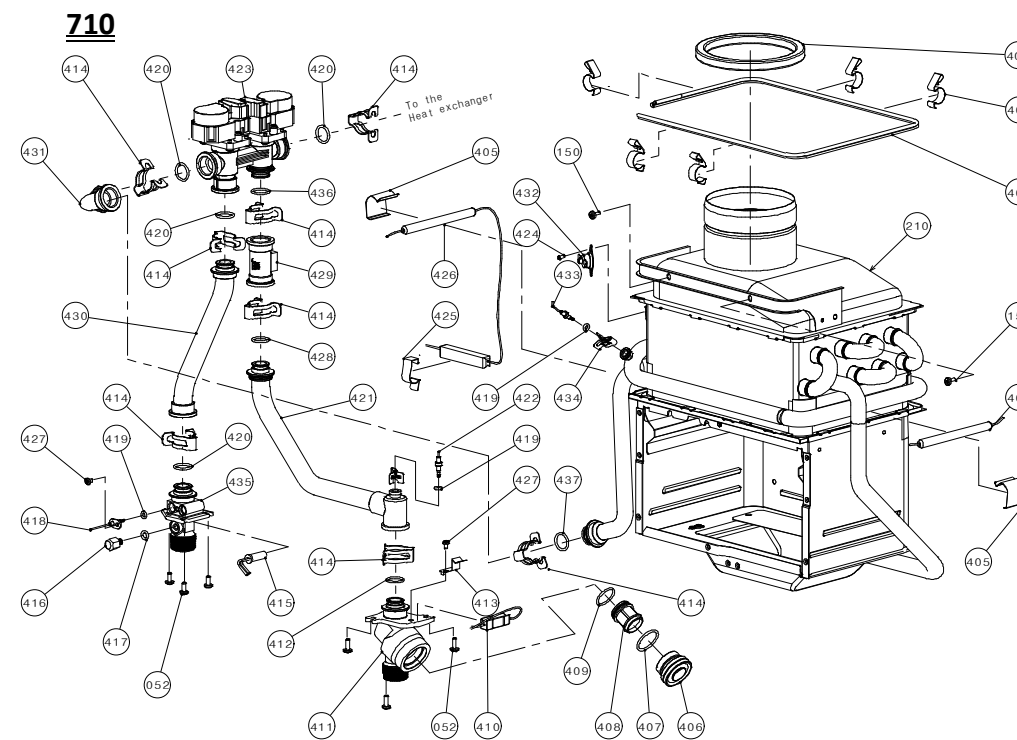

Item#	Part#	Description
210	319143-302	Heat exchanger assembly for 710
211	319143-314	Heat exchanger assembly for 710 ASME
401	319143-065	Silicon ring
402	319143-066	Fuse fixing plate 18
403	319143-286	Overheat-cut-off fuse
404	319143-224	Pipe heater 122
405	319143-088	Heater fixing plate
406	319143-070	Filter plug
407	319143-071	O-ring P25 FKM
408	319143-072	Water inlet filter
409	319143-073	O-ring JASO# 1021 FKM
410	319143-068	Heater 101
411	319143-074	Water inlet
412	319143-075	O-ring JASO# 1016 FKM
413	319143-076	Heater plate
414	319143-077	Fastener "16AG"
415	319143-078	Heater
416	319143-079	Outlet drain plug
417	319143-080	O-ring P6 FKM
418	319143-081	Mixing thermistor
419	319143-082	O-ring P4 FKM
420	319143-083	O-ring P16 FKM
421	319143-288	Cold pipe for 710
422	319143-085	Inlet thermistor
423	319143-086	Water control valve

710 ASME

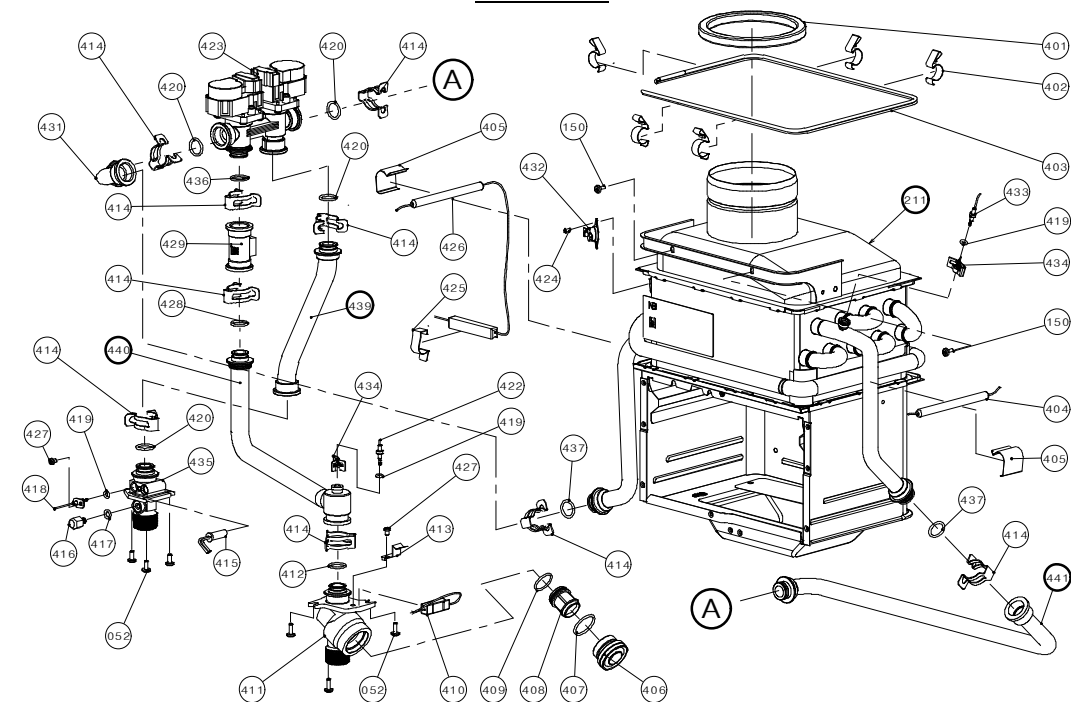

Item#	Part#	Description
424	319143-087	Screw M3x6
425	319143-125	Heater fixing plate 16
426	319143-321	Pipe heater 212
427	319143-090	Pan screw M4x6 (W/Washer)
428	319143-091	O-ring P15 FKM
429	319143-092	Flow sensor
430	319143-289	Hot pipe for 710
431	319143-318	L joint
432	319143-095	Hi-limit switch
433	319143-096	Output thermistor
434	319143-097	Fastener "4-11"
435	319143-098	Water outlet
436	319143-099	O-ring JASO# 1017 FKM
437	319143-349	O-ring P18 FKM
439	319143-316	Hot pipe for 710 ASME
440	319143-315	Cold pipe for 710 ASME
441	319143-317	Connection pipe for 710 ASME

Item#	Part#	Description
701	319143-279	710 PCB
702	319143-309	Transformer
703	319143-322	Junction box inner plate
704	319143-290	Gas valve wire
705	319143-293	"Flow sensor, Gas proportional valve connection and Thermistors" wire for 710
706	319143-324	"Flow sensor, Gas proportional valve connection and Thermistors" wire for 710 ASME
707	319143-292	Flame rod wire
708	319143-143	Nylon clamp
709	319143-320	Igniter & Freeze protection wire

Item#	Part#	Description
710	319143-291	AC 100V wire
711	319143-297	AC100V Transformer connecting wire
712	319143-227	Ground fault circuit interrupter
713	319143-296	Power supply code assembly
714	319143-295	AC120V Transformer connecting wire
715	319143-284	Surge box
716	319143-280	PCB fixing plate
717	319143-294	Remote controller terminal
718	319143-331	Screw M3x12
719	319143-343	Screw M4x12
720	319143-323	PCB cover