



COMMERCIAL-GRADE RESIDENTIAL GAS WATER HEATERS

PROLINE® HIGH RECOVERY ATMOSPHERIC VENT 75 & 100 GALLON COMMERCIAL-GRADE RESIDENTIAL

HIGHEST RECOVERIES

- Capacity/input combinations up to 98 gallons/75,100 BTU's produce recoveries up to 81 gallons per hour.

FULLY AUTOMATIC CONTROLS WITH SAFETY SHUTOFF

- Accurate, dependable control system requires no electric connections.
- Fixed automatic gas shutoff device for added safety.

GREEN CHOICE® GAS BURNER

- Patented eco-friendly burner design reduces NOx emissions up to 33% and complies with Low-NOx emission requirements of 40 ng/l.

SELF-CLEANING DIP TUBE

- Reduces lime and sediment buildup, maximizes hot water output. Made from long-lasting Pex cross-linked polymer

COREGARD™ ANODE ROD

- Our anode rods have a stainless steel core that extends the life of the anode rod allowing superior tank protection far longer than standard anode rods.

PUSH-BUTTON PIEZO IGNITOR

- Makes lighting the pilot fast and easy with one-hand push-button spark ignition (Natural gas only).

NIPPLES

- Factory-Installed for faster installation

BLUE DIAMOND® GLASS COATING

- Provides superior corrosion resistance compared to industry-standard glass lining.

ENHANCED-FLOW BRASS DRAIN VALVE

- Our residential water heaters have a solid brass, tamper resistant, enhanced-flow, ball type, drain valve.
- Uses a standard female hose fitting that allows for fast and easy draining during maintenance.
- Designed for easy operation, this valve includes an integral screwdriver slot that features a 1/4 turn (open/close) radius, which not only permits full straight-through water flow but also a quick and positive shut off.

CODE COMPLIANCE

- Meets UBC, CEC and ICC National Codes.
- Meets the thermal efficiency and standby loss requirements of the U.S. Department of Energy and current edition of ASHRAE/IES 90.1

CSA CERTIFIED AND ASME RATED T&P RELIEF VALVE

MAXIMUM HYDROSTATIC WORKING PRESSURE 150 PSI

DESIGN-LISTED BY UNDERWRITERS LABORATORIES

- Certified at 300 psi test pressure and 150 psi working pressure.
- Listed according to ANSI Z21. 10.3 CSA 4.3 standards governing storage tank-type water heaters.

6-YEAR LIMITED TANK AND PARTS WARRANTY

- For complete information, consult written warranty or State Water Heaters.



SOLID. STATE.



COMMERCIAL-GRADE

RESIDENTIAL GAS WATER HEATERS

Model Number	Gallon Capacity	BTU Input Natural Gas	Recovery @ 90°F Rise Gallon Per Hour	Dimensions in Inches									Approx. Shipping Weight (lbs)
				A	B	C	D	E	F	G	H	Draft Hood	
GS6 75 XRRS	74	75,100	81	61	57	26-1/2	14-3/4	16	50-1/4	15-1/2	50-1/4	4	275
GS6 100 XRRT	98	75,100	81	68-1/2	65	27-3/4	15-3/16	16	57-3/8	N/A	N/A	4	350

Recovery capacity are based on actual performance tests.
 Water connections are- 1" on GS6 75 XRRS and 1-1/4" on GS6 100 XRRT.
 For 10- year tank and 6-year parts limited warranty, change "6" to "X" in the model number (example: GSX 75 XRRS).
 For optional side-mounted recirculating taps, add "L" to suffix (example: GS6 75 XRRS L).
 When ordering propane (LP) gas change "X" to "C" in the model number (example: GS6 75 CRRS).
 Dimensions and specifications subject to change without notice in accordance with our policy of continuous product improvement.

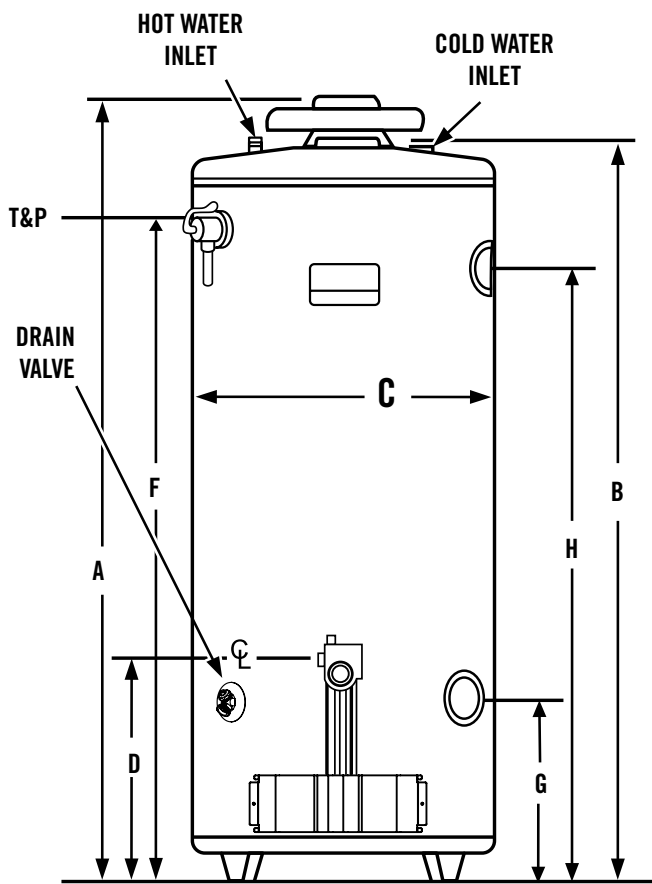

FRONT VIEW

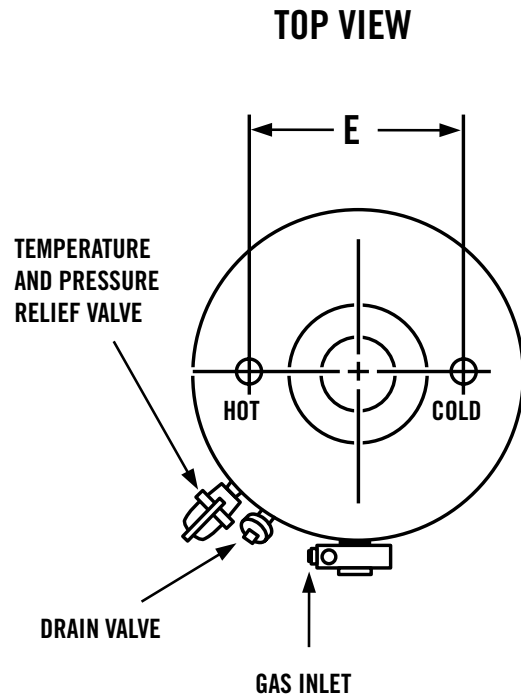

TOP VIEW