

# REPAIR PART ILLUSTRATION

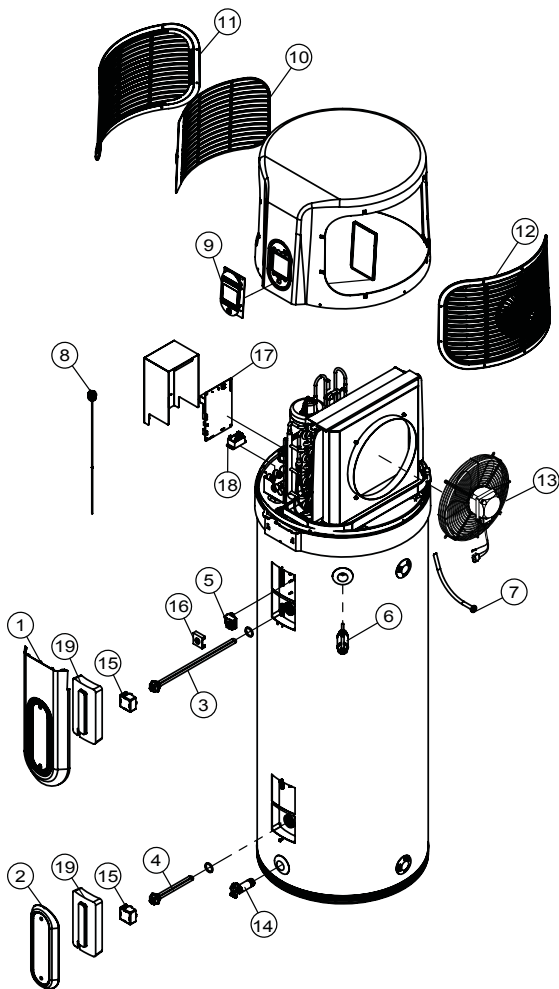

## REPAIR PARTS LIST

ITEM NO.	PARTS DESCRIPTION
1	Upper Access Cover
2	Lower Access Cover
3	Upper Element (4500 Watts)
4	Lower Element (2000 Watts)
5	Energy Cut-Off (ECO) Switch
6	Temperature & Pressure Relief Valve (T&P)
7	Dip Tube (at hot water outlet)
8	Powered Anode Rod
9	User Interface Module
10	Air Filter
11	Air Inlet Side Panel
12	Air Outlet Side Panel
13	Fan Assembly
14	Drain Valve
15	Protective Plastic Cover
16	ECO Cover
17	Control Board
18	Relay
19	EPS Cover
20*	Ambient / Coil / Discharge Temperature Sensor
21*	Upper / Lower Tank Temperature Sensor
22*	Run Capacitor
23*	Control Board Module Fuses

\* NOT SHOWN

## REPAIR PARTS

Repair parts may be ordered through your plumber, local distributor, home improvement center, or by calling 1-800-365-0024. When ordering repair parts always give the following information:

1. Model, serial and product number
2. Item number
3. Parts description