

Residential & Commercial Full Line Pocket Guide

STATE WATER HEATERS FULL PRODUCT LINE POCKET GUIDE



SOLID. STATE.

When it comes to building durability into a product, nobody does it like State. In fact, we've tested our water heaters in some of the most hostile environments and under the toughest conditions to make sure they last longer and provide many more years of hot water.

TABLE OF CONTENTS

Introduction.....	3
Introducing the ProLine® Family.....	4
Contractor Rewards.....	5
ProLine® Family Features.....	6
Features and Benefits.....	7

RESIDENTIAL GAS

Premier® High Efficiency Power Vent.....	8-9
Premier® High Efficiency Power Direct Vent.....	10-11
Polaris™ High Efficiency.....	12-13
ProLine® XE Power Vent.....	14-15
ProLine® XE Non-Condensing Power Direct Vent.....	16-17
ProLine® XE High Efficiency.....	18-19
ProLine® XE High Efficiency Non-Condensing Flue Damper.....	20-21
ProLine® XE High Efficiency Non-Condensing Ultra-Low NOx Flue Damper.....	22-23
ProLine® XE Ultra-Low NOx Power Vent.....	24-25
ProLine® Master Atmospheric Vent.....	26-29
ProLine® Master Ultra-Low NOx.....	30-31
ProLine® High Recovery Atmospheric Vent 75 & 100 Gallon.....	32-33
ProLine® Direct Vent.....	34-35
ProLine® Atmospheric Vent.....	36-39
ProLine® Mobile Home Atmospheric Vent.....	40-41
ProLine® Mobile Home Direct Vent.....	42-43
ProLine® Ultra-Low NOx.....	44-45
ProLine® Ultra-Low NOx Direct Vent.....	46-47
ProLine® Ultra-Low NOx High Recovery.....	48-49

RESIDENTIAL HYBRID ELECTRIC

ProLine® XE Hybrid Electric Heat Pump - 10-Year Warranty.....	50-51
ProLine® XE Hybrid Electric Heat Pump - 6-Year Warranty.....	52-53

RESIDENTIAL ELECTRIC

ProLine® XE Electronic Display.....	54-55
ProLine® Master.....	56-57
ProLine® Standard.....	58-59
Mobile Home.....	60-61
ProLine® Specialty.....	62-63

COMMERCIAL & RESIDENTIAL PUMP AND EXPANSION TANKS

Pump Mate™.....	64-65
Heavy-Duty State ProLine® Glasslined.....	66-67
Heavy-Duty State ProLine® Galvanized.....	68-69
Waterguard™, TW Series & Therm-o-Flex™.....	70-71
Therm-o-Flex™.....	72-73

TABLE OF CONTENTS

TANKLESS

ProLine® XE Condensing with Recirculation Pump.....	74-75
ProLine® XE Condensing High Efficiency.....	76-77
ProLine® XE Condensing High Efficiency.....	78-79
ProLine® XE Non-Condensing Concentric Vent.....	80-81
ProLine® XE Non-Condensing.....	82-83
ProLine® XE Non-Condensing Ultra-Low NOx.....	84-85
Tankless Non-Condensing Heavy-Duty.....	86-87
Tankless Commercial Rack System.....	88-91

BUILDING MANAGEMENT SYSTEM

BACnet and Modbus Interface.....	92-93
----------------------------------	-------

COMMERCIAL GAS AND OIL FIRED

Force® 90 Power Vent.....	94-95
Force® 90+ Power Direct Vent.....	96-97
Force® 90+ Power Direct Vent.....	98-99
Modulating Ultra Force®.....	100-103
Polaris™ High Efficiency.....	104-105
Sandblaster® Self Cleaning - SBD Series.....	106-109
Sandblaster® Booster Models.....	110-111
Sandblaster® Ultra-Low NOx.....	112-115
Sandblaster® - SBS Series.....	116-117
Sandblaster® Light-Duty.....	118-119
Force® Power Direct Vent.....	120-121
Sandblaster® Low NOx Single Flue.....	122-123
State Titan® Power Gas Burner.....	124-125
State Titan® Low NOx Power Gas Burner.....	126-127
State Titan® LV Power Gas Heavy-Duty TPG.....	128-131
State Titan® LV Power Oil Heavy-Duty Large Volume.....	132-135
State Titan® Power Burner GPO Series Oil.....	136-137

COMMERCIAL ELECTRIC

Patriot™ Light-Service Electric.....	138-139
Patriot™ Light-Duty Electric.....	140-141
Sandblaster® Immersion Mount Thermostat - CSB Series.....	142-143
Sandblaster® Surface Mount Thermostat - CSB Series.....	144-145
Statesman™ Premium Heavy-Duty Electric - SSE Series.....	146-147

COMMERCIAL STORAGE TANKS

Standard Jacketed Storage Tanks.....	148-149
Custom-Line Factory Jacketed & Insulated Storage Tanks.....	150-153
Uninsulated Standard Stock Bare.....	154-155
Heavy-Duty Large Volume Storage Tanks.....	156-159



ABOUT STATE WATER HEATERS

State Water Heaters, a brand of State Industries, Inc., is a leading manufacturer of commercial and residential water heaters. State offers 500 water heater products and has consistently developed new technologies to ensure longer product life. Based in Ashland City, Tennessee, State has seven water heater manufacturing plants. Hundreds of distribution centers across the United States ensure efficient service to State's national customer base of residential homeowners, wholesalers, contractors, and other members of the engineering community. All State products are backed by solid customer technical support and durable tank and parts warranty.



HISTORY

In 1946, State Water Heaters was founded by Herbert Lindahl, Sr. as a small entrepreneurial company producing coal and wood-burning stoves in a garage in Nashville, Tennessee. In the years that followed, State expanded and became a leader in the water heating industry through steadfast commitments to seeking new materials, new technology and innovative engineering techniques. Landmark moments in State's proud history include:

- 1948** State produces its first electric water heater.
- 1954** State expands product lines and manufactures first gas-fired water heaters.
- 1956** State manufactures its first welded-steel galvanized tanks.
- 1957** State produces its first porcelain glass-lined tanks; the basic design feature is still in use today.
- 1979** State is granted U.S. patents for their Sandblaster® commercial water heater design.
- 1996** State is the world's largest water heater manufacturer with over 2900 employees and average daily production of over 10,000 units. The company introduces a complete new product line that includes the Premier® and ProLine® models.



Introducing the ProLine® Family of Commercial-Grade Residential Water Heaters



ProLine® XE Premier®

ProLine® Master

ProLine®

When it comes to building a tough commercial-grade water heater, the keys to success are outstanding components and superior manufacturing capabilities. We've combined these two important elements to create the ProLine® family of commercial-grade residential water heaters. This wholesale-channel exclusive will give State Water Heaters' contractors the ultimate advantage.

WHY PROFESSIONALS CHOOSE STATE

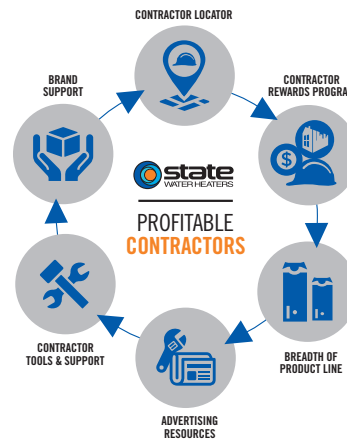

With over 1,000,000 merchandise items, your reward choices are endless.

EARN POINTS BY PURCHASING STATE WATER HEATERS.

IT'S FREE AND EASY TO PARTICIPATE. Enroll online at contractorrewards.com. Eligible products will have a yellow reward code label worth valuable points. Two ways to enter the codes:

1. Download the smartphone app and scan the code
2. Enter the code at contractorrewards.com
3. Redeem your points on thousands of reward items

STATE PROVIDES 6 KEY THINGS TO HELP GROW YOUR BUSINESS AND BECOME MORE PROFITABLE.

1. CONTRACTOR LOCATOR

A new online locator that drives thousands of consumers from our websites right to our loyal contractors.

2. Contractor Advertising Tools

Our Dealer Marketing Resource Center allows contractors to develop an easy, affordable and custom advertising campaign to promote their business.

3. BREADTH OF PRODUCT LINE

Residential or commercial, we have the most complete line from standard models to the most innovative high efficiency water heaters available.

4. PRODUCT SALES TOOLS

We provide contractors access to the sales tools needed to close more sales.

5. CONTRACTOR REWARDS™ PROGRAM

Our program rewards our loyal contractors for buying our products. Buy more and get rewarded with prizes and higher status on our contractor locator.

6. BRAND SUPPORT

Marketing investment in our brand drives consumers to recognize our name, visit our website, locate local contractors and request our products.

*To be listed on the Contractor Locator you must meet the minimum threshold of codes entered at ContractorRewards.com



CONTRACTOR REWARDS.COM
Your Business. Your Choices. Your Rewards.

To learn more visit: statewaterheaters.com/contractorlocator

STATE WATER HEATERS

PREMIUM FEATURES. COMMERCIAL-GRADE RESIDENTIAL WATER HEATERS.



	PROLINE® GOOD	PROLINE® MASTER BETTER	PROLINE® XE BEST
OPERATING COST	\$\$\$	\$\$	\$
INSTALLATION SPACE REQUIRED	■ to ■■	■■	■ to ■■■
WARRANTY COVERAGE (YEARS)	6	8	6-15
PREMIUM FEATURES:			
Blue Diamond® Glass Coating**	●	●	●
Self-Cleaning Automatic Sediment-Cleaning System**	●	●	●
Self-Powered Electronic Gas Valve*	●	●	●
Heat Trap Nipples**	●	●	●
Enhanced Flow Brass Drain Valve**	●	●	●
CoreGard™ Advanced Anode Rod Protection**	●	●●	●
Energy Saving	Meets Requirement	Meets Requirement	●
Electronic User Interface			●
Condensing Combustion*			●
Continuous Flow*			●
Cutting-Edge Technology Industry-Leading Efficiency			●
Double Long Life Elements***			●

* These features apply to gas products only

** These features apply to tank-type products only

*** These features apply to electric products only

Hot Water Output, Cost of Operation, & Installation Space Required estimated based on typical applications/installations. For a more custom analysis of unique installations, visit statewaterheaters.com and use our product selector tool.



WHAT GOES INTO MAKING STATE BRAND PRODUCTS LAST

Blue Diamond® Glass Coating
State residential gas and electric water heaters have the toughest protection against corrosion to maximize tank life.

State's Blue Diamond® Glass Coating provides superior corrosion resistance compared to the industry-standard glass lining.



Self-Cleaning Systems on State Residential Models

Automatic self-cleaning action greatly reduces lime and sediment buildup, maximizes hot water output. Made from long-lasting Pex cross-linked polymer.

Our ProLine® XE models come standard with maximum sediment-fighting power and utilize our top-of-the-line Turbo Coil design.

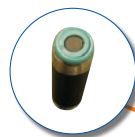

Heat Trap Nipples
Factory-installed for faster installation on most State residential models.



CoreGard™ Anode Rod
Our anode rods have a stainless steel core that extends the life of the anode rod, allowing superior tank protection far longer than standard anode rods.

DURABILITY



Enhanced-Flow Brass Drain Valve
Our residential water heaters have a solid brass, tamper resistant, enhanced-flow, ball type drain valve.

- Uses a standard female hose fitting that allows for fast and easy draining during maintenance.
- Designed for easy operation, this valve includes an integral screwdriver slot that features a 1/4 turn (open/close) radius, which not only permits full straight-through water flow but also a quick and positive shut off.



Green Choice® Gas Burner
Patented eco-friendly burner design reduces NOx emissions by up to 33% and complies with Low-NOx emission requirements of less than 40 ng/l.



ENERGY STAR®
State Water Heaters offers a variety of models that are ENERGY STAR® qualified. Learn more at www.energystar.gov.



LOW LEAD CONTENT
CSA low lead logo on a plumbing product signifies certification to California's AB1953 and Vermont's legislation Act 193 that limits the lead content in plumbing fixtures that come in contact with drinking water to a maximum of 0.25% lead.

PREMIER® HIGH EFFICIENCY POWER VENT



PROLINE® XE
BEST



POWER VENT DESIGN FOR INSTALLATION VERSATILITY

- Helical internal heat exchanger achieves 90% thermal efficiency, which saves money on operating costs compared to a standard 80% efficient gas water heater.
- Combined horizontal and vertical vent runs terminating through outside wall, using Schedule 40 PVC pipe as follows:
 - 2" pipe allows vent runs up to 25 equivalent feet.
 - 3" pipe allows vent runs up to 65 equivalent feet.
 - 4" pipe allows vent runs up to 128 equivalent feet.

SIDE-MOUNTED TAPS FOR RECIRCULATING SYSTEMS

- Hot and cold "side taps" allow Premier Power Vent to be used for combination space/water heating applications.

INTELLI-VENT™* GAS CONTROL WITH SILICON NITRIDE HOT SURFACE IGNITOR

- Premium-grade hot surface ignitor eliminates standing pilot.
- Electronic circuitry provides superior system diagnostic capabilities plus extremely precise temperature control.

BLUE DIAMOND® GLASS COATING WITH TWO HEAVY DUTY ANODE RODS

- Provides superior corrosion resistance compared to the industry-standard glass lining.

GREEN CHOICE® GAS BURNER

- Patented eco-friendly burner design reduces NOx emissions by up to 33% and complies with Low-NOx emission requirements of less than 40 ng/J.

SELF-CLEANING DIP TUBE

CSA CERTIFIED AND ASME RATED T&P RELIEF VALVE

MAXIMUM HYDROSTATIC WORKING PRESSURE: 150 PSI

CODE COMPLIANCE

- Meets UBC, CEC and ICC National Codes.
- Meets the thermal efficiency and standby loss requirements of the U.S. Department of Energy and Current edition of ASHRAE/IES 90.1.

6-YEAR LIMITED TANK AND PARTS WARRANTY

- For complete information, consult written warranty or go to statewaterheaters.com.

*Intelli-Vent is a registered trademark of Emerson Electric Company

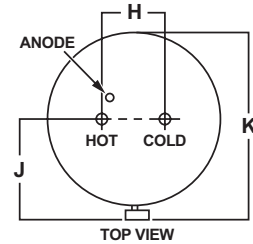

*INSTALL IN ACCORDANCE WITH LOCAL CODES

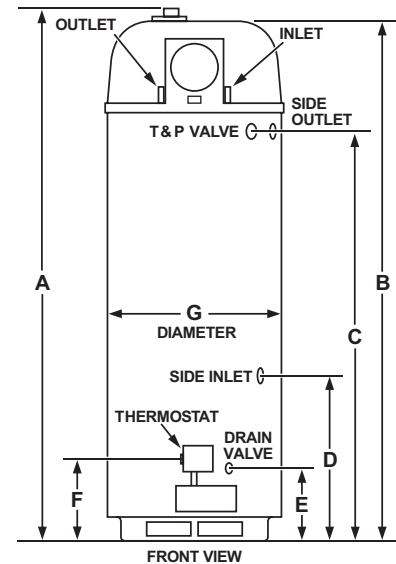

Model Number	Gallon Capacity	Recovery @ 90°F Rise Gallon Per Hour	BTU Input Gallon Per Hour	First Hour Rating	Approx. Shipping Weight (lbs)
GP6 50 YTVIT	50	92	76,000	127	210

Model Number	Dimensions in Inches				
	A	B	C	D	E
GP6 50 YTVIT	71	68-5/8	52	21	9-1/8

Model Number	F	G	H	J	K
	GP6 50 YTVIT	12	22	8	15-3/4

Available in natural gas only.
Standard model certified for sea level to 5,300 ft. elevation. Specify high altitude when ordering for use in elevations up to 10,100 ft.
Optional Condensate Neutralizer Kit available (part number 100112380).

PREMIER® HIGH EFFICIENCY POWER DIRECT VENT



**PROLINE® XE
BEST**



GP6 75 YTPDT



HELICAL INTERNAL HEAT EXCHANGER

- Spiral heat exchanger keeps hot combustion gases in the tank longer to lengthen the heat transfer cycle.

POWER DIRECT VENT DESIGN.

- Combined vertical and horizontal runs terminating through an outside wall. Vents using PVC, CPVC or ABS pipe.
 - 2" pipe, vents up to 45 equivalent feet.
 - 3" pipe, vents up to 128 equivalent feet.

CONDENSING DESIGN

- 96% efficient condensing design.
- Equipped with condensate drain tee.

SIDE-MOUNTED HOT AND COLD RECIRCULATING TAPS

- Allows the ProLine® XE to be installed as part of combination space heating/water heating applications.

ADVANCED ELECTRONIC CONTROL

- Large LCD Display.
- Precise temperature control.
- Advanced diagnostics.
- iCOMM™ compatible and can be monitored from remote locations. Call 1.888.WATER02 for more information.

CODE COMPLIANCE

- Complies with SCAQMD Rule 1146.2 and other air quality management districts with similar requirements for Ultra-Low NOx emissions requirements of 14 ng/J or 20ppm.
- Meets UBC, CEC and ICC National Codes.
- Meets the thermal efficiency and standby loss requirements of the U.S. Department of Energy and current edition of ASHRAE/IES 90.1.

6-YEAR LIMITED TANK AND PARTS WARRANTY

- For complete information, consult written warranty or go to statewaterheaters.com.

ROUGH IN DIMENSIONS: 50 GALLON UNIT

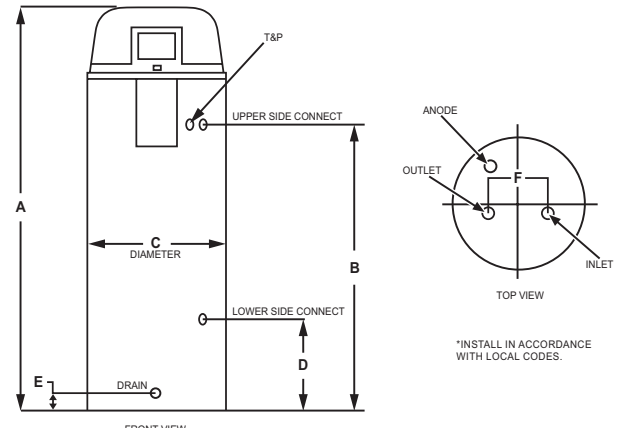

ROUGH IN DIMENSIONS: 75 GALLON UNIT

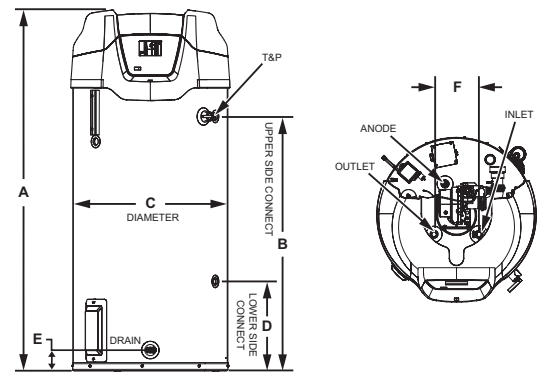

Model Number	Gallon Capacity	Recovery @ 90°F Rise Gallon Per Hour	BTU Input Per Hour	Vent Size	Approx. Shipping Weight (lbs)
GP6 50 YTPDT	50	129	100,000	2 or 3	255
GP6 75 YTPDT	75	129	100,000	2 or 3	382

Model Number	Dimensions in Inches					
	A	B	C	D	E	F
GP6 50 YTPDT	66-3/4	49-1/4	22	15-3/4	3	8
GP6 75 YTPDT	65-1/4	45-5/8	27-3/4	16	3-3/4	8

Available in Propane (LP) gas. Change "Y" to "H" in the model number (example: GP6 50 HTPDT).
Models certified from sea level to 10,100 ft. elevation.
Optional Condensate Neutralizer Kit available (Part Number 100112380).

POLARIS™ HIGH EFFICIENCY



**PROLINE® XE
BEST**



CONDENSING DESIGN

- Operates at up to 96% thermal efficiency which saves money on operating costs compared to a standard 80% efficient gas water heater.
- Helical internal heat exchanger keeps hot combustion gases in the tank longer to extract more heat into the water.

STAINLESS STEEL CONSTRUCTION

- Tank and helical heat exchanger are constructed from 444 stainless steel for excellent corrosion resistance without the need for an anode.

WHISPER QUIET OPERATION

- Ultra-quiet blower and burner minimize noise.

POWER DIRECT VENT DESIGN

- Direct vent using PVC, CPVC or ABS either thru-the-wall or thru-the-roof.

OPTIONAL CONCENTRIC VENT KIT

ADVANCED ELECTRONIC CONTROL

- Large LCD display provides precise temperature control and advanced diagnostics.

CODE COMPLIANCE

- Complies with SCAQMD Rule 1146.2 and other air quality management districts with similar requirements for Ultra-Low NOx emissions requirements of 14 ng/l or 20 PPM.
- Meets UBC, CEC, and ICC National Codes.
- Meets the thermal efficiency and standby loss requirements of the U. S. Department of Energy and current edition of ASHRAE/IES 90.1.

10-YEAR LIMITED TANK AND 1-YEAR LIMITED PARTS WARRANTY

- For complete information, consult written warranty or go to statewaterheaters.com.

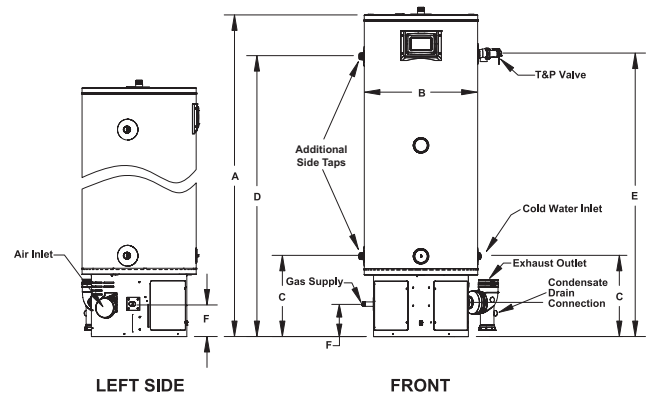
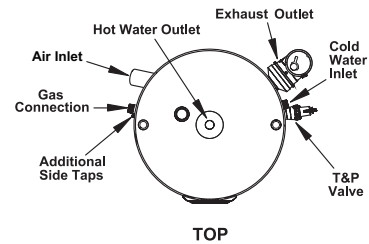

Model Number	Gallon Capacity	BTU/h Input Gallon Per Hour	Thermal Efficiency	Recovery @ 90° Rise Gallon Per Hour	Approx. Shipping Weight (lbs)
GHX 34 100 N	34	100,000	96%	129	150
GHX 34 130 N	34	130,000	96%	165	150
GHX 34 150 N	34	150,000	94%	190	150
GHX 50 130 N	50	130,000	95%	165	176
GHX 50 150 N	50	150,000	95%	190	180
GHX 50 175 N	50	175,000	96%	222	180
GHX 50 199 N	50	199,000	96%	253	180

Model Number	Dimensions in Inches		Vent Connection	1" Water Connections		T&P	Gas Supply*
	A	B		C	D		
GHX 34 100 N	48-1/2	22	2 or 3	15-3/4	40-1/2	41	6-3/8
GHX 34 130 N	48-1/2	22	2 or 3	15-3/4	40-1/2	41	6-3/8
GHX 34 150 N	48-1/2	22	2 or 3	15-3/4	40-1/2	41	6-3/8
GHX 50 130 N	62-3/8	22	2 or 3	15-3/4	54-1/2	55	6-3/8
GHX 50 150 N	63-3/4	22	2 or 3	15-3/4	55-3/4	56-1/4	6-3/8
GHX 50 175 N	63-3/4	22	3	15-3/4	55-3/4	56-1/4	6-3/8
GHX 50 199 N	63-3/4	22	3	15-3/4	55-3/4	56-1/4	6-3/8

For Propane (LP) gas change "N" to "P".
Models certified for sea level to 7,700 ft. elevation.

PROLINE® XE POWER VENT



PROLINE® XE
BEST



VERSATILE POWER VENT DESIGN

- All models feature an exclusive 3-position rotatable blower outlet which adds flexibility.
- Combined horizontal and vertical vent runs up to 180 equivalent feet with 4" diameter venting (ABS, PVC, CPVC and polypropylene).
- All models are equipped with a protected sensor that detects the presence of flammable vapors and automatically disables the burner to prevent ignition.
- Air intake snorkel elevates the inlet location of combustion air to prevent flammable vapors from entering the sealed combustion chamber.

HOT SURFACE IGNITOR

- More robust and reliable than standing pilot, and reduces energy consumption.

BUILT-IN HEAT TRAPS ON THE WATER INLET AND OUTLET REDUCE THE AMOUNT OF HEAT LOST THROUGH PIPING

2-INCH-THICK, ENVIRONMENTALLY FRIENDLY FOAM INSULATION REDUCES THE AMOUNT OF HEAT LOSS AND CONTRIBUTES TO OVERALL ENERGY EFFICIENCY

USER-FRIENDLY

- State-of-the-art electronic gas control provides more precise temperature control.
- LED control light displays operation status and diagnostics information.

ENHANCED-FLOW BRASS DRAIN VALVE

AVAILABLE IN NATURAL GAS AND PROPANE

CODE COMPLIANCE:

- Meets UBC, CEC and HUD National Codes.
- Meets the thermal efficiency and standby loss requirements of the U.S. Department of Energy and current edition of ASHRAE/IES 90.1.
- Complies with the Federal Energy Conservation Standards effective April 16, 2015, in accordance with the Energy Policy and Conservation Act (EPCA) as amended.

6-YEAR LIMITED TANK AND PARTS WARRANTY

- For complete information, consult written warranty or go to statewaterheaters.com.

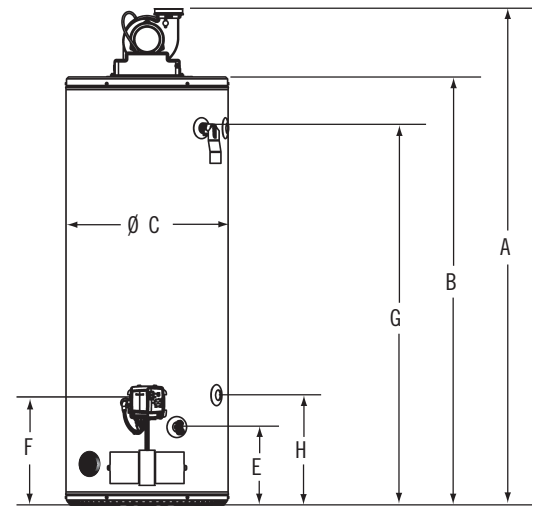
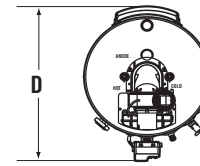

Model Number	Series	Gallon Capacity	Energy Factor (EF)	Recovery @ 90°F Rise Gallon Per Hour	BTU Input Gallon Per Hour	First Hour Rating	Approx. Shipping Weight (lbs)
GS6 40 YBVIS	200	40	0.7	45	40,000	72	174
GS6 40 YRVIT	200	40	0.7	56	50,000	93	176
GS6 50 YBVIS	200	50	0.7	45	40,000	93	198
GS6 50 YRVIT	200	50	0.7	56	50,000	96	192
GS6 50 YRVHSL	200	50	0.7	69	62,000	108	212
†GS6 75 YRVHTL	210	75	N/A	80	76,000	N/A	277

Model Number	Dimensions in Inches							
	A	B	C	D	E	F	G	H
GS6 40 YBVIS	59	49-5/8	22	29-1/8	11	13-1/4	42-1/2	15-1/4
GS6 40 YRVIT	68-1/2	59-1/4	20	27-1/8	11	13-1/4	53-1/8	15-1/4
GS6 50 YBVIS	60-1/8	50-3/4	24	31-1/8	11	13-1/4	43-3/4	15-1/4
GS6 50 YRVIT	68-1/8	58-3/4	22	29-1/8	11	13-1/4	51-3/4	15-1/4
GS6 50 YRVHSL	61-1/8	52	24	31-1/8	11	13-1/4	44-1/2	15-1/4
†GS6 75 YRVHTL	70-5/8	61-1/4	26	33-1/8	11	13-1/4	53	15-1/4

Available in Propane (LP) gas. Change "Y" to "H" in the model number (example: GS6 40 **H**BVIS). Models GS6 50 YRVHSL5 and GS6 75 YRVHTL come from the factory standard with side loop fittings. YRVIT models available with side connections for use in combination applications. All models are certified from 10,100 ft. elevation. † GS6 75 YRVHTL is not ENERGY STAR® Qualified.

PROLINE® XE NON-CONDENSING POWER DIRECT VENT



**PROLINE® XE
BEST**



POWER DIRECT VENT DESIGN

- Combined horizontal and vertical vent runs up to 180 equivalent feet with 4" diameter venting (ABS, PVC, CPVC and polypropylene).
- Two-pipe sealed combustion system uses outside air, eliminating problems caused by insufficient indoor ventilation.

GREEN CHOICE® GAS BURNER

- Patented eco-friendly gas burner design reduces NOx and complies with Low-NOx emission requirements of less than 40 ng/l.

HOT-SURFACE IGNITOR

- More robust and reliable than standing pilot, and reduces energy consumption.

SELF-CLEANING DIP TUBE

USER-FRIENDLY

- State-of-the-art electronic gas control provides more precise temperature control.
- LED control light displays operation status and diagnostics information.

ENHANCED-FLOW BRASS DRAIN VALVE

CSA CERTIFIED AND ASME RATED T&P RELIEF VALVE

CODE COMPLIANCE:

- Meets UBC, CEC and HUD National Codes.
- Meets the thermal efficiency and standby loss requirements of the U.S. Department of Energy and current edition of ASHRAE/IES 90.1.
- Complies with the Federal Energy Conservation Standards effective April 16, 2015, in accordance with the Energy Policy and Conservation Act (EPCA) as amended.

DESIGN-LISTED BY CSA INTERNATIONAL

- Certified at 300 psi test pressure and 150 psi working pressure.
- Listed according to ANSI Z21. Z21.10.1-CSA 4.1 standards governing storage tank-type water heaters.

6-YEAR LIMITED TANK AND PARTS WARRANTY

- For complete information, consult written warranty or go to statewaterheaters.com.

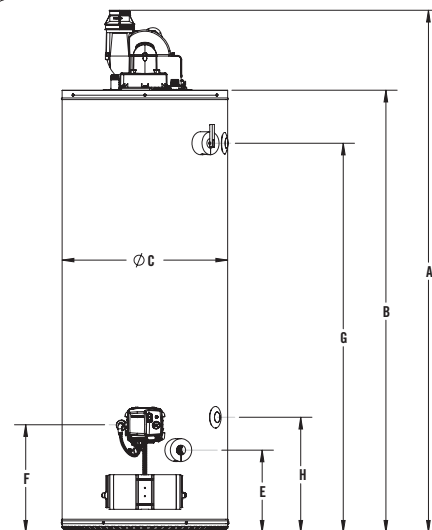
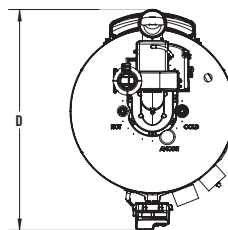

Model Number	Series	Gallon Capacity	Input BTU/h	Energy Factor	First Hour Rating Gallon	Recovery @ 90°F Rise Gallon Per Hour	Approx. Shipping Weight (lbs)
GS6 40 YBPDS	200	40	40,000	0.71	71	45.2	174
GS6 50 YBPD	200	50	45,000	0.7	93	50.3	192
GS6 50 YRPDTL 5	200	50	62,000*	0.71	115	72.6	200
†GS6 75 YRPDTL	210	75	76,000	N/A	N/A	82.4	277

Model Number	Dimensions in Inches							
	A	B	C	D	E	F	G	H
GS6 40 YBPDS	58-1/4	49-5/8	22	29-7/8	11	13-1/4	42-1/2	15-1/4
GS6 50 YBPD	67-1/2	58-3/4	22	29-7/8	11	13-1/4	51-3/4	15-1/4
GS6 50 YRPDTL 5	69	60-1/4	22	29-7/8	11	13-1/4	52-3/4	15-1/4
†GS6 75 YRPDTL	70-5/8	61-1/2	26	33-7/8	11	13-1/4	53	15-1/4

* Propane model has input of 58,000 BTU/hr.

Available in Propane (LP) gas. Specify when ordering Propane (LP) gas.

Side connections standard on GS6 50 YRPDTL5 & GS6 75 YRPDTL models

Side connections available on YBPDS and YBPD models.

All models are certified from sea level to 10,100 ft. elevation.

† GS6 75 YRPDTL is not ENERGY STAR® Qualified.

PROLINE® XE HIGH EFFICIENCY



**PROLINE® XE
BEST**



PRESSURIZED COMBUSTION SYSTEM INSTALLATION FRIENDLY

- Allows for easy replacement of standard atmospheric vent heater.
- Easily connects to existing B-vent.

FAN-ASSISTED, CATEGORY 1 APPLIANCE

- Plugs into standard 110/120V outlet (10 foot power cord included).

24V ELECTRONIC CONTROLS

ELECTRONIC IGNITION

LCD USER INTERFACE

- Easy-to-read eye level display.
- Simple temperature settings and adjustments.
- Service diagnostics are in plain text.

POWERED ANODE ROD

ENHANCED-FLOW BRASS DRAIN VALVE

SELF-CLEANING DIP TUBE

GREEN CHOICE® GAS BURNER

- Patented eco-friendly gas burner design reduces NOx emissions by up to 33% and complies with Low-NOx emission requirements of less than 40 ng/J.

CODE COMPLIANCE

- Meets UBC, CEC and HUD National Codes.
- Meets the thermal efficiency and standby loss requirements of the U. S. Department of Energy and current edition of ASHRAE/IES 90.1.
- Complies with the Federal Energy Conservation Standards effective April 16, 2015, in accordance with the Energy Policy and Conservation Act (EPCA), as amended.

DESIGN-CERTIFIED BY CSA INTERNATIONAL

- Certified at 300 psi test pressure and 150 psi working pressure. Listed according to ANSI Z21.10.1- CSA 4.1 standards governing storage tank-type gas water heaters.

6-YEAR LIMITED TANK AND PARTS WARRANTY

- For complete information, consult written warranty or go to statewaterheaters.com.

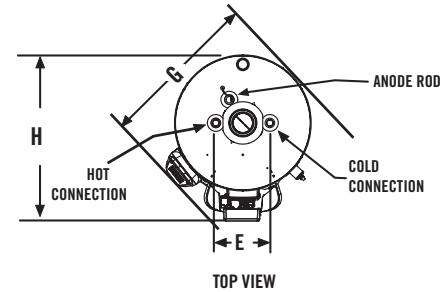

TOP VIEW

Maximum Hydrostatic Working Pressure: 150 PSI

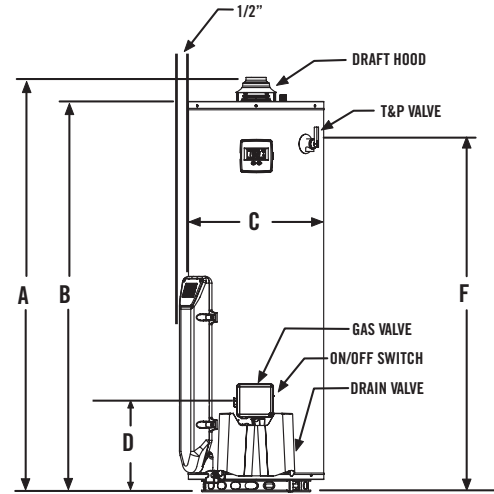

FRONT VIEW

Model Number	Gallon Capacity	First Hour Rating Gallons	Energy Factor (EF)	BTU Input Gallon Per Hour	Recovery @ 90°F Rise Gallon Per Hour	Draft Hood (Inches)	Approx. Shipping Weight (lbs)
GP6 40 YPCT	40	70	0.7	40,000	43	3 or 4	157
GP6 50 YPCT	50	81	0.7	40,000	43	3 or 4	171

Model Number	Foam Thickness	Dimensions in Inches							
		A	B	C	D	E	F	G	H
GP6 40 YPCT	2	61-3/4	58	20	13-1/4	8	51-1/2	23-1/4	25
GP6 50 YPCT	2	60-5/8	57-1/8	22	13-1/4	8	50-1/2	25-1/4	27

Available in natural gas only.
Water connection is 3/4" on all models.
All models are certified from sea level to 10,100 ft. elevation.
Requires 120 VAC power supply.



PROLINE® XE HIGH EFFICIENCY NON-CONDENSING FLUE DAMPER



PROLINE® XE
BEST



AUTOMATIC FLUE DAMPER

- Increases efficiency as it automatically opens and closes to reduce heat loss in the standby mode.

ELECTRONIC GAS CONTROL

DIAGNOSTICS

ELECTRONIC IGNITION

SELF-CLEANING DIP TUBE

GREEN CHOICE® GAS BURNER

- Patented eco-friendly burner design reduces NOx emissions by up to 33% and complies with Low-NOx emission requirements of less than 40 ng/J.

COREGARD™ ANODE ROD

ENHANCED-FLOW BRASS DRAIN VALVE

BLUE DIAMOND® GLASS COATING

CSA CERTIFIED AND ASME RATED T&P RELIEF VALVE

CODE COMPLIANCE

- Meets UBC, CEC and HUD National Codes.
- Meets the thermal efficiency and standby loss requirements of the U.S. Department of Energy and current edition of ASHRAE/IES 90.1.
- Complies with the Federal Energy Conservation Standards effective April 16, 2015, in accordance with the Energy Policy and Conservation Act, (EPCA), as amended.

DESIGN-CERTIFIED BY CSA INTERNATIONAL

- Certified at 300 psi test pressure and 150 psi working pressure.
- Listed according to ANSI Z21.10.1 - CSA 4.1 standards governing storage tank-type water heaters.

6-YEAR LIMITED TANK AND PARTS WARRANTY

- For complete information, consult written warranty or go to statewaterheaters.com.

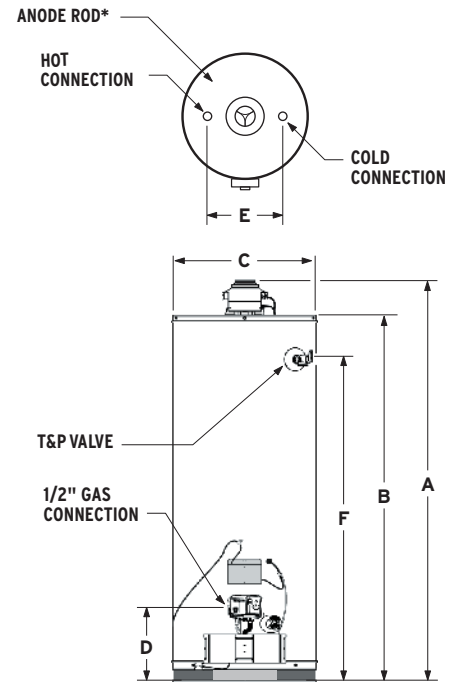

Model Number	Gallon Capacity	First Hour Rating Gallons	Energy Factor (EF)	BTU Input Gallon Per Hour Natural*	Recovery @ 90°F Rise Gallon Per Hour	Approx. Shipping Weight (lbs)
Tall Models						
GS6 40 YBFT	40	67	0.67	40,000	42	152
GS6 50 YBFT	50	81	0.67	40,000	42	167
Short Models						
GS6 40 YBFS	40	67	0.67	40,000	42	149
*GS6 50 YBFS	50	88	0.67	40,000	42	175

Model Number	Dimensions in Inches							Draft Hood Outlet
	Foam Thickness	A	B	C	D	E	F	
Tall Models								
GS6 40 YBFT	2	64-1/4	58-1/4	20	13	8	51-3/4	3 or 4
GS6 50 YBFT	2	63-1/2	57-1/4	22	13	8	50-1/4	3 or 4
Short Models								
GS6 40 YBFS	2	54	47-3/4	22	13	8	41	3 or 4
*GS6 50 YBFS	2	55-3/4	49-1/2	24	13-1/4	8	42-1/2	3 or 4

Requires 120 VAC power supply.

Water connection is 3/4" on all models.

When ordering top-mounted T&P valve, add "G" to the model number (example: GS6 40 YBFT G).

All models are certified from sea level to 10,100 ft. elevation.

* GS6 50 YBFS available in natural gas only, all other models available in propane (LP) gas.



PROLINE® XE HIGH EFFICIENCY NON-CONDENSING ULTRA-LOW NOx FLUE DAMPER



**PROLINE® XE
BEST**



ENERGY STAR® EFFICIENCY

- Eco-friendly non-CFC foam insulation and an automatic flue damper increase efficiency to provide maximum household annual operating cost savings.

GREEN CHOICE® GAS BURNER

- Enhanced Ultra-Low NOx burner complies with SCAQMD Rule 1121 and other air quality management districts with similar requirements for NOx emissions of less than 10ng/J.

ELECTRONIC GAS CONTROL

SELF-CLEANING DIP TUBE

COREGARD™ ANODE ROD

BLUE DIAMOND® GLASS COATING

ENHANCED-FLOW BRASS DRAIN VALVE

REQUIRES 120V POWER 19.5' CORD INCLUDED

CODE COMPLIANCE

- Meets UBC, CEC and HUD (excluding mobile homes) National Codes.
- Meets the thermal efficiency and standby loss requirements of the U.S. Department of Energy and current edition of ASHRAE/IES 90.1.
- Complies with the Federal Energy Conservation Standards effective April 16, 2015, in accordance with the Energy Policy and Conservation Act, (EPCA), as amended.

CSA AND DESIGN-CERTIFIED BY CSA INTERNATIONAL

- Certified at 300 psi test pressure and 150 psi working pressure.
- Listed according to ANSI Z21.10.1 - CSA 4.1 standards governing storage tank-type water heaters.

6-YEAR LIMITED TANK AND PARTS WARRANTY

- For complete information, consult written warranty or go to statewaterheaters.com.

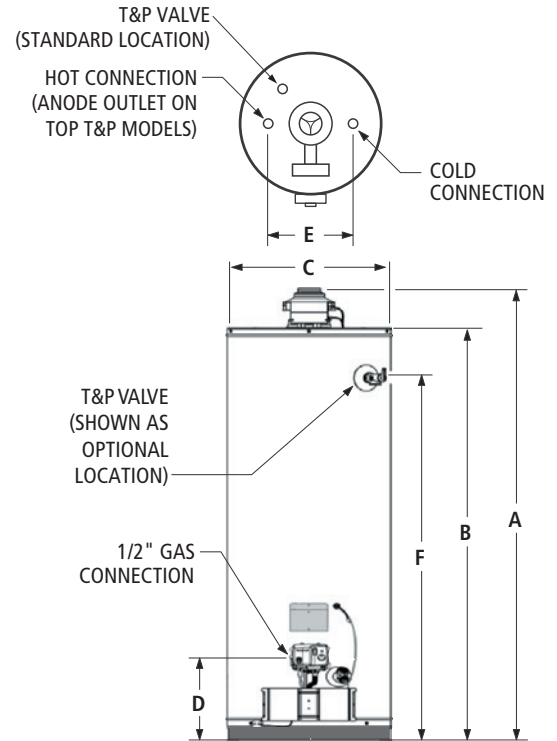

Maximum Hydrostatic Working Pressure: 150 PSI.

Model Number	Gallon Capacity	First Hour Rating Gallon Per Hour	Energy Factor	BTU Input Natural Gas	Recovery @ 90F Rise (Gallon/Hour)	Approx. Shipping Weight (lbs)
GS6-40-BFUT	40	74	0.67	40,000	42	152
GS6-50-BFUT	50	90	0.67	40,000	42	167

Model Number	Foam Thickness	Dimensions in Inches						Draft Hood
		A	B	C	D	E	F	
GS6-40-BFUT	2	64-1/4	58-1/4	20	13	8	51-3/4	3 or 4
GS6-50-BFUT	2	63-1/2	57-1/4	22	13	8	50-1/4	3 or 4

Requires 120VAC power supply located within 19ft of the heater.
Water connection is 3/4" on all models.
Standard top T&P, specify when ordering side T&P.
All models are certified from sea level to 7,800ft elevation.

PROLINE® XE ULTRA-LOW NO_x POWER VENT



PROLINE® XE
BEST



POWER VENTING MADE SIMPLE

- Thru-the-Wall or Thru-the-Roof power venting using either 2" or 3" PVC, ABS or CPVC vent pipe.

INTELLI-VENT™ GAS CONTROL

- Advanced electronics for more precise control of water temperature and easy to understand system diagnostics.

COMBINATION THERMOSTAT/ECO

- Utilizes an intermittent ignition gas valve (no standing pilot) with thermistor temperature sensor and built-in high temperature cut off.

QUIET AND EFFICIENT BLOWER

- Factory-installed 6-foot power cord with 3-prong male connector provided. Electrical requirements; 110/120 VAC power source, less than 5 amp draw.

SELF-CLEANING DIP TUBE

- Helps reduce lime and sediment buildup and maximizes hot water output. Made from long-lasting PEX cross-linked polymer.

COREGARD™ ANODE ROD

GREEN CHOICE® GAS BURNER

- Complies with SCAQMD Rule 1121 and other air quality management districts with similar requirements for NO_x emissions of less than 10 ng/J.

ENHANCED-FLOW BRASS DRAIN VALVE

CODE COMPLIANCE

- Meets UBC, CEC and HUD National Codes.
- Meets the thermal efficiency and standby loss requirements of the U. S. Department of Energy and current edition of ASHRAE/IES 90.1.
- Complies with the Federal Energy Conservation Standards effective April 16, 2015, in accordance with the Energy Policy Conservation Act (EPCA), as amended.

6-YEAR LIMITED TANK AND PARTS WARRANTY

- For complete information, consult written warranty or go to statewaterheaters.com.

Top View

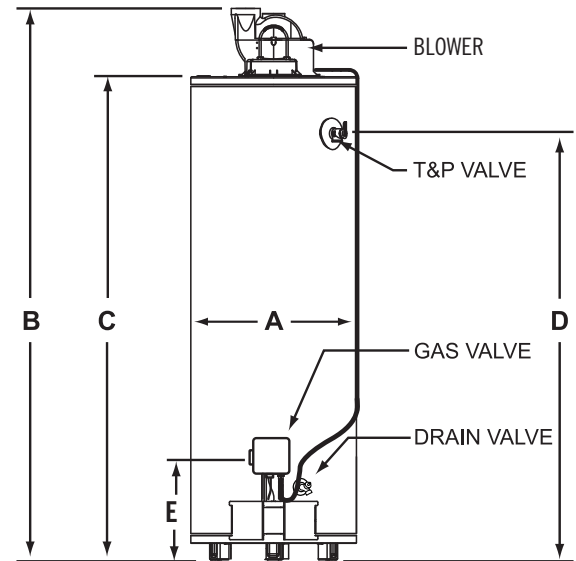
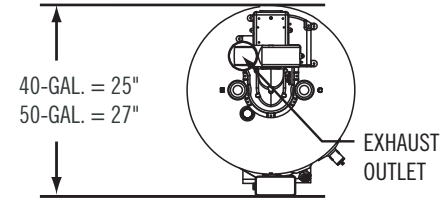

Model Number	Gallon Capacity	First Hour Rating Gallon Per Hour	Energy Factor	Recovery @ 90°F Rise Gallon Per Hour	BTU Input Gallon Per Hour	Approx. Shipping Weight (lbs)
GS6 40 UBKIT	40	69	0.68	42.6	42,000	170
GS6 50 UBKIT	50	81	0.68	42.6	42,000	207

Model Number	Dimensions in Inches					
	A	B	C	D	E	Draft Hood
GS6 40 UBKIT	20	66-7/8	58-5/8	51-1/2	12-1/4	2 or 3
GS6 50 UBKIT	22	66-5/8	57-7/16	51	12-1/4	2 or 3

No option available for top T&P valve.

**PROLINE® MASTER
BETTER**



INTELLIGENT CONTROL LOGIC

- The internal microprocessor provides enhanced operating parameters and tighter differentials for precise sensing and faster heating response to optimize performance.
- Uses a thermopile to generate the power needed to operate the electronic gas control without requiring an external power source.
- The electronic gas control incorporates an LED status indicator that monitors system operation and service diagnostics.

*Not available on 60,000 BTU input models (GW8 50 RCT and GW8 55 RCT).

SELF-CLEANING DIP TUBE

COREGARD™ ANODE ROD

- ProLine Master products have increased anode protection with either longer, or multiple anodes depending on model.

PUSH-BUTTON PIEZO IGNITOR

ENHANCED-FLOW BRASS DRAIN VALVE

HEAT TRAP NIPPLES

BLUE DIAMOND® GLASS COATING

- Blue Diamond® Glass Coating blend is formulated in the same lab that creates the protection for our industry-leading commercial product line.

CODE COMPLIANCE

- Meets UBC, CEC and HUD National Codes.
- Meets the thermal efficiency and standby loss requirements of the U. S. Department of Energy and current edition of ASHRAE/IES 90.1.
- Complies with the Federal Energy Conservation Standards effective April 16, 2015, in accordance with the Energy Policy and Conservation Act, (EPCA), as amended.

DESIGN-CERTIFIED BY CSA INTERNATIONAL

- Certified at 300 psi test pressure and 150 psi working pressure.
- Listed according to ANSI Z21.10.1-CSA 4.1 standards governing storage tank-type water heaters.

8-YEAR LIMITED TANK AND PARTS WARRANTY

- For complete information, consult written warranty or go to statewaterheaters.com.

Model Number	Gallon Capacity	First Hour Rating Gallon	Energy Factor	BTU Input Natural Gas	BTU Input Propane Gas	Recovery 90°F Rise Gallon Per Hour	Approx. Shipping Weight (lbs)
Tall Models							
GW8 40 BCT	40	70	0.62	40,000	36,000	42	138
GW8 50 BRT	50	88	0.60	40,000	37,000	41	148
GW8 50 BCT	50	88	0.62	40,000	37,000	43	165
GW8 50 RCT*	50	92	0.60	50,000	45,000	54	165
GW8 55 XCT*	55	106	0.59	60,000	54,000	65	185
Short Models							
GW8 40 BCS	40	68	0.62	40,000	36,000	41	135
GW8 50 BCS	50	93	0.60	40,000	40,000	43	177

Water connection is 3/4" on all models.

*Optional side-mounted recirculating taps, add "L" to the suffix in the model number (GW8 50 RCTL).

All models approved for installation from sea level to 10,100 ft. elevation.

Dimensions and line drawings on the following pages.



PROLINE® MASTER ATMOSPHERIC VENT (CONTINUED)

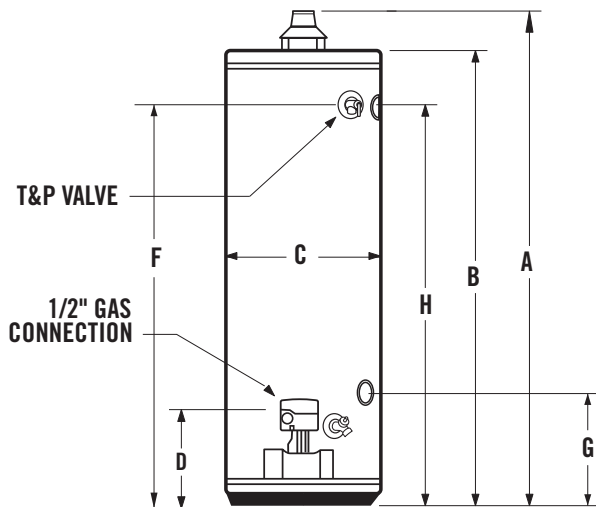
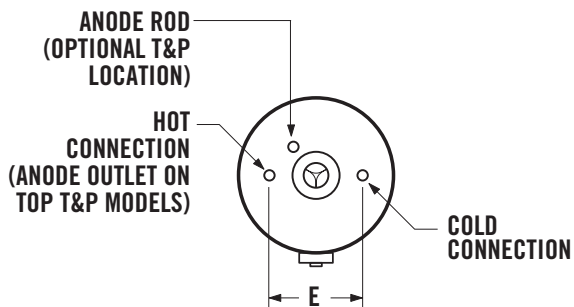

Maximum Hydrostatic Working Pressure: 150 PSI

Model Number	Dimensions in Inches								
	A	B	C	D	E	F	*G	*H	Draft Hood
Tall Models									
GW8 40 BCT	61-3/4	58-1/4	20	12-1/4	8	52	14-1/4	51-3/4	3 or 4
GW8 50 BRT	60-3/4	57-1/4	21	12-1/4	8	50 1/2	14-1/4	50-1/2	3 or 4
GW8 50 BCT	60-3/4	57-1/4	22	12-1/4	8	50-1/2	14-1/4	50-1/2	3 or 4
GW8 50 RCT*	60-3/4	57-1/4	22	12-1/4	8	50-1/2	14-1/4	50-1/2	4
GW8 55 XCT*	59-3/4	55-1/4	24	13-1/2	8	48	14-1/4	48	4
Short Models									
GW8 40 BCS	51-1/2	48	22	12	8	41-1/4	N/A	N/A	3 or 4
GW8 50 BCS	53-1/4	49-3/4	24	12	8	41-3/8	N/A	N/A	3 or 4

Water connection is 3/4" on all models.

*Optional side-mounted recirculating taps, add "L" to the suffix in the model number (GW8 50 RCTL).

All models approved for installation from sea level to 10,100 ft. elevation.

**PROLINE® MASTER
BETTER**



THE ELECTRONIC GAS CONTROL INCORPORATES AN LED STATUS INDICATOR THAT MONITORS SYSTEM OPERATION AND SERVICE DIAGNOSTICS

HIGH ENERGY FACTORS

- Eco-friendly non-CFC foam insulation, heat traps and specially designed combustion chamber combine to produce a high Energy Factor for maximum savings on operating costs.

GREEN CHOICE® GAS BURNER

- Enhanced Ultra-low NOx burner complies with SCAQMD Rule 1121 and other air quality management districts with similar requirements for NOx emissions of less than 10 ng/j.

SELF-CLEANING DIP TUBE

COREGARD™ ANODE ROD

- ProLine® Master products have increased anode protection with either longer, or multiple anodes depending on model.

PUSH-BUTTON PIEZO IGNITOR

HEAT TRAP NIPPLES

BLUE DIAMOND® GLASS COATING

- Blue Diamond® Glass Coating blend is formulated in the same lab that creates the protection for our industry-leading commercial product line.

ENHANCED-FLOW BRASS DRAIN VALVE

CODE COMPLIANCE

- Meets UBC, CEC and HUD National Codes.
- Meets the thermal efficiency and standby loss requirements of the U.S. Department of Energy and current edition of ASHRAE/IES 90.1.
- Complies with the Federal Energy Conservation Standards effective April 16, 2015, in accordance with the Energy Policy Conservation Act (EPCA), as amended.

DESIGN-CERTIFIED BY CSA INTERNATIONAL

- Certified at 300 psi test pressure and 150 psi working pressure.
- Listed according to ANSI Z21.10.1-CSA 4.1 standards governing storage tank-type gas water heaters.

8-YEAR LIMITED TANK AND PARTS WARRANTY

- For complete information, consult written warranty or go to statewaterheaters.com.

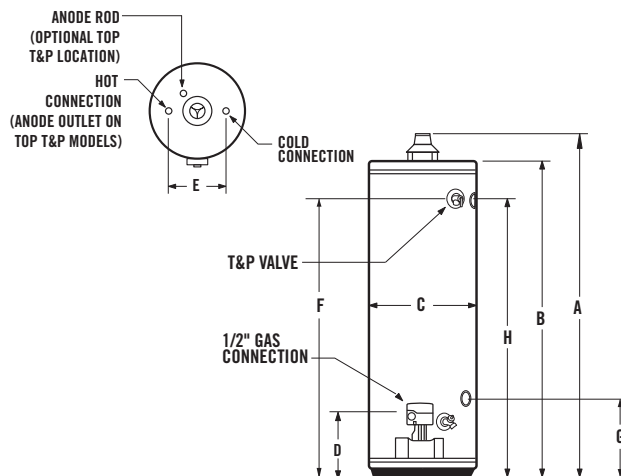

Maximum Hydrostatic Working Pressure: 150 PSI



Model Number	Gallon Capacity	First Hour Rating Gallon	Energy Factor	BTU Input Natural Gas	Recovery @ 90°F Rise Gallon Per Hour	Approx. Shipping Weight (lbs)
Tall Models						
GW8 40 BCUT	40	71	0.63	40,000	41	125
GW8 50 BCUT	50	91	0.62	40,000	42	148
GW8 50 RCUTL*	50	98	0.60	50,000	51	177
Short Models						
GW8 40 BCUS	40	69	0.62	40,000	41	138

Model Number	Dimensions in Inches								
	A	B	C	D	E	F	G*	H*	Draft Hood
Tall Models									
GW8 40 BCUT	62	58-1/4	20	12	8	52	N/A	N/A	3 or 4
GW8 50 BCUT	60-3/4	57-1/4	22	12	8	50-1/2	N/A	N/A	3 or 4
GW8 50 RCUTL*	61	57-1/2	22	12-1/4	8	50-1/2	12-1/4	50-1/2	4
Short Models									
GW8 40 BCUS	51-1/2	47-3/4	22	12	8	41-1/4	N/A	N/A	3 or 4

All models may be ordered from the factory with top T&P valve as an option by adding "G" to the suffix of the model number (example GW8 40 BCUTG).

*Side loop connections are standard on model GW8 50 RCUTL.

*Most models approved for installation from sea level to 7,700 ft. elevation (except GW8 50 RCUTL, approved to 5,400 ft.).

PROLINE® HIGH RECOVERY ATMOSPHERIC VENT 75 & 100 GALLON



**PROLINE®
GOOD**

HIGHEST RECOVERIES

- Capacity/input combinations up to 98 gallons/75,100 BTUs produce recoveries up to 81 gallons per hour.

THE ELECTRONIC GAS CONTROL INCORPORATES AN LED STATUS INDICATOR THAT MONITORS SYSTEM OPERATION AND SERVICE DIAGNOSTICS

GREEN CHOICE® GAS BURNER

- Patented eco-friendly burner design reduces NOx emissions up to 33% and complies with Low-NOx emission requirements of 40 ng/J.

SELF-CLEANING DIP TUBE

COREGARD™ ANODE ROD

PUSH-BUTTON PIEZO IGNITOR

BLUE DIAMOND® GLASS COATING

ENHANCED-FLOW BRASS DRAIN VALVE

CODE COMPLIANCE

- Meets UBC, CEC and ICC National Codes.
- Meets the thermal efficiency and standby loss requirements of the U.S. Department of Energy and current edition of ASHRAE/IES 90.1.

DESIGN-CERTIFIED BY CSA INTERNATIONAL

- Certified at 300 psi test pressure and 150 psi working pressure.
- Listed according to ANSI Z21.10.1-CSA4.1 standards governing storage tank-type gas water heaters. CSA Certified and ASME Rated T&P Relief Valve

MAXIMUM HYDROSTATIC WORKING PRESSURE 150 PSI

DESIGN-LISTED BY UNDERWRITERS LABORATORIES

- Certified at 300 psi test pressure and 150 psi working pressure.
- Listed according to ANSI Z21.10.3 CSA 4.3 standards governing storage tank-type water heaters.

6-YEAR LIMITED TANK AND PARTS WARRANTY

- For complete information, consult written warranty or go to statewaterheaters.com.

TOP VIEW

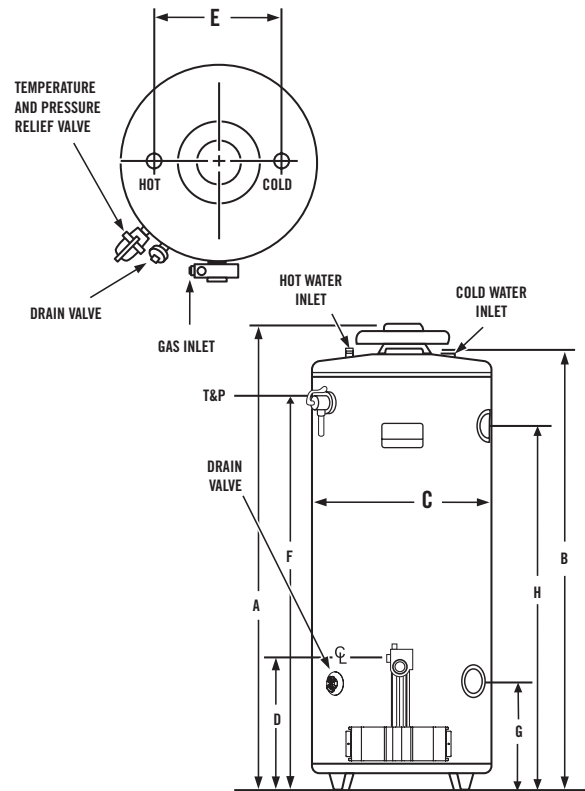

FRONT VIEW

Model Number	Gallon Capacity	BTU Input Natural Gas	Recovery @ 90°F Rise Gallon Per Hour	Approx. Shipping Weight (lbs)
GS6 75 XRRS	74	75,100	81	275
GS6 100 XRRT	98	75,100	81	350

Model Number	Dimensions in Inches								Draft Hood
	A	B	C	D	E	F	G	H	
GS6 75 XRRS	61	58-1/2	26-1/2	15-3/16	16	50-1/4	15-1/2	50-1/4	4
GS6 100 XRRT	68-1/2	66-1/2	27-3/4	15-3/16	16	57-3/8	N/A	N/A	4

Water connections are 1" male NPT on GS6 75 XRRS and 1-1/4" on GS6 100 XRRT. All models are certified from sea level to 7,700 ft. elevation.

For 10-year tank and 6-year parts limited warranty, change "6" to "X" in the model number (example: GSX 75 XRRS).

For optional side-mounted recirculating taps, add "L" to suffix (example: GS6 75 XRRS L).

When ordering propane (LP) gas change "X" to "C" in the model number (example: GS6 75 CRRS).

PROLINE® DIRECT VENT



DIRECT VENT DESIGN

- One-pipe, dual-channel closed system draws all make-up air from outside the home, eliminating problems caused by insufficient indoor ventilation and is FVIR compliant.
- Horizontal air intake and venting on all models up to 80 inches from outside wall with no electrical power needed.

INTELLIGENT CONTROL LOGIC

GREEN CHOICE® GAS BURNER

- Patented eco-friendly gas burner design reduces NOx emissions by up to 33% and complies with Low-NOx emission requirements of less than 40 ng/l.

SELF-CLEANING DIP TUBE

COREGARD™ ANODE ROD

PUSH BUTTON PIEZO IGNITOR

HEAT TRAP NIPPLES

CODE COMPLIANCE

- Meets UBC, CEC and HUD National Codes.
- Meets the thermal efficiency and standby loss requirements of the U.S. Department of Energy and current edition of ASHRAE/IES 90.1.
- Complies with the Federal Energy Conservation Standards effective April 16, 2015, in accordance with the Energy Policy and Conservation Act (EPCA), as amended.

DESIGN-CERTIFIED BY CSA INTERNATIONAL

- Certified at 300 psi test pressure and 150 psi working pressure. Listed according to ANZI Z21. 10.1-CSA 4.1 standards governing storage tank-type gas water heaters.

6-YEAR LIMITED TANK AND PARTS WARRANTY

- For complete information, consult written warranty or go to statewaterheaters.com.

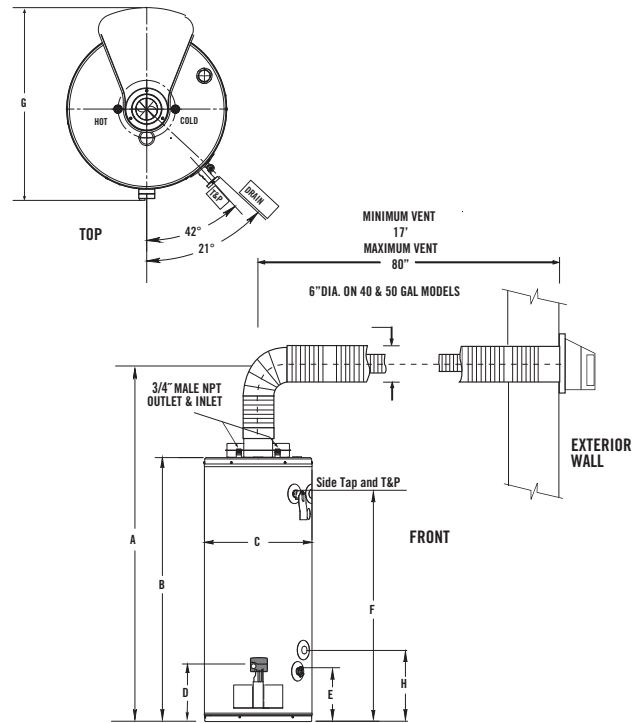

Model Number	Gallon Capacity	First Hour Rating Gallon	Energy Factor	Recovery 90°F Rise Gallon Per Hour	Input BTU per Hour	Vent Outlet	Approx. Shipping Weight (lbs)
GS6 40 YBDS	40	72	0.63	41	38,000	Co-Axial	178
GS6 50 YBDS	50	91	0.62	43	40,000	Co-Axial	200
GS6 50 YRDS	50	92	0.61	51	47,000	Co-Axial	215

Model Number	Dimensions in Inches							
	A	B	C	D	E	F	*G	H
GS6 40 YBDS	64	49-3/4	22	13-1/4	15-1/4	42-1/2	29	15-1/4
GS6 50 YBDS	73	59	22	13-1/4	15-1/4	51-3/4	29	15-1/4
GS6 50 YRDS	74	60	22	13-1/4	15-1/4	52-3/4	29	15-1/4

Dual-channel system has 3" vent pipe inside 6" air intake pipe, for the 40 and 50-gallon models. All models have 2" foam cavity.

Water connection is 3/4" male on all models.

40 and 50 gallon models are 8" on center.

* Allow 29-1/2" front to back dimensions for air intake at rear of heater.

All models are available in propane (LP) gas (series 301).

All models are certified from sea level to 7,700 ft. elevation.

All models are available with side loop fittings. Add "L" to the model number (example: GS6 40 YBDS L).





INTELLIGENT CONTROL LOGIC

- The internal microprocessor provides enhanced operating parameters and tighter differentials for precise sensing and faster heating response to optimize performance.
- Uses a thermopile to generate the power needed to operate the electronic gas control without requiring an external power source.
- The electronic gas control incorporates an LED status indicator that monitors system operation and service diagnostics.

*Not available on 60,000 BTU input models (GCRX-50 and GCRX-55).

SELF CLEANING DIP TUBE

COREGARD™ ANODE ROD

PUSH-BUTTON PIEZO IGNITOR

ENHANCED-FLOW BRASS DRAIN VALVE

HEAT TRAP NIPPLES

BLUE DIAMOND® GLASS COATING

CODE COMPLIANCE

- Meets UBC, CEC and HUD National Codes.
- Meets the thermal efficiency and standby loss requirements of the U. S. Department of Energy and current edition of ASHRAE/IES 90.1.
- Complies with the Federal Energy Conservation Standards effective April 16, 2015, in accordance with the Energy Policy and Conservation Act, (EPCA), as amended.

DESIGN-CERTIFIED BY CSA INTERNATIONAL

- Certified at 300 psi test pressure and 150 psi working pressure.
- Listed according to ANSI Z21.10.1-CSA 4.1 standards governing storage tank-type water heaters.

6-YEAR LIMITED TANK AND PARTS WARRANTY

- For complete information, consult written warranty or go to statewaterheaters.com.



Model Number	Gallon Capacity	First Hour Rating Gallon	Energy Factor	BTU Input Natural Gas	BTU Input Propane Gas	Recovery @ 90°F Rise Gallon Per Hour	Approx. Shipping Weight (lbs)
TALL MODELS							
†GS6 30 ORBT	30	64	0.63	35,500	32,000	37	123
GS6 30 OCT	30	67	0.63	35,500	32,000	37	132
‡GS6 40 OCT	40	67	0.62	35,500	N/A	38	138
†GS6 40 BRBT	40	70	0.62	40,000	36,000	42	130
GS6 40 BCT*	40	70	0.62	40,000	36,000	42	138
GS6 50 BRT*	50	88	0.60	40,000	37,000	41	148
GS6 50 BCT*	50	88	0.62	40,000	37,000	43	165
GS6 50 RCT*	50	92	0.60	50,000	45,000	54	165
†GS6 50 XCT*	50	98	0.60	60,000	54,000	65	182
GS6 55 XCT*	55	106	0.59	60,000	54,000	65	185
SHORT MODELS							
†GS6 30 ORBS	30	56	0.63	35,500	32,000	37	110
GS6 30 OCS	30	62	0.63	35,500	32,000	37	118
†GS6 40 BRBS	40	67	0.62	40,000	36,000	41	134
GS6 40 BCS	40	68	0.62	40,000	36,000	41	135
GS6 50 BCS	50	93	0.60	40,000	40,000	43	177

Water connection is 3/4" on all models.

*Optional side-mounted recirculating taps, add "L" to the suffix in the model number (GS6 50 RCTL).

† Models ship with supplied insulation blanket.

For 10-year tank and 6-year parts limited warranty, change "6" to "X" in the model number (example: GSX 30 OCT).

All models approved for installation from sea level to 10,100 ft. elevation.

‡ LP models not available on GS6 40 OCT.

Dimensions and line drawings on the following pages.

PROLINE® ATMOSPHERIC VENT (CONTINUED)

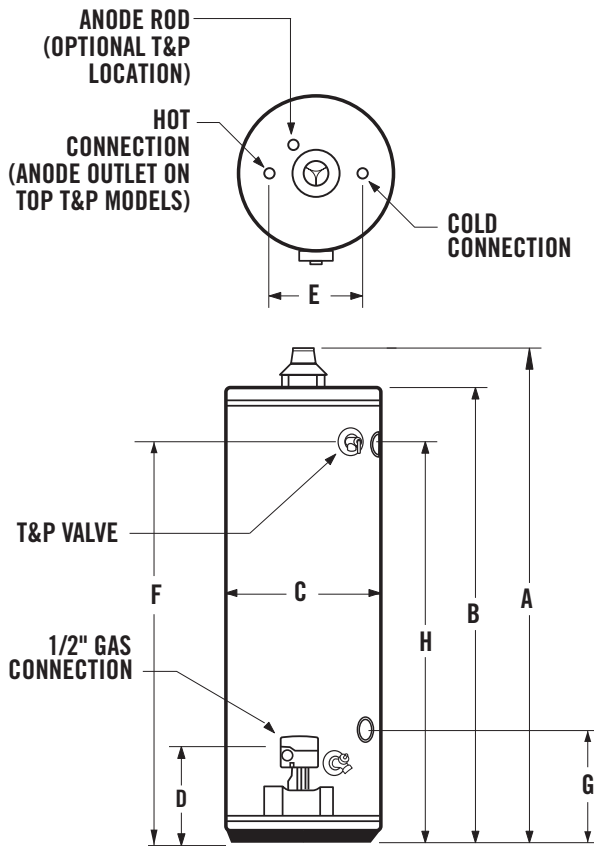

Maximum Hydrostatic Working Pressure: 150 PSI

Model Number	Dimensions in Inches								Draft Hood
	A	B	C	D	E	F	*G	*H	
TALL MODELS									
†GS6 30 ORBT	61-1/2	58	16	12-1/4	8	51-3/4	N/A	N/A	3 or 4
GS6 30 OCT	61-1/2	58	18	12-1/4	8	51-3/4	N/A	N/A	3 or 4
‡GS6 40 OCT	61-3/4	58-1/4	20	12-1/4	8	52	N/A	N/A	3 or 4
†GS6 40 BRBT	61-3/4	58-1/4	18	12-1/4	8	52	N/A	N/A	3 or 4
GS6 40 BCT*	61-3/4	58-1/4	20	12-1/4	8	52	14-1/4	51-3/4	3 or 4
GS6 50 BRT*	60-3/4	57-1/4	21	12-1/4	8	50 1/2	14-1/4	50-1/2	3 or 4
GS6 50 BCT*	60-3/4	57-1/4	22	12-1/4	8	50-1/2	14-1/4	50-1/2	3 or 4
GS6 50 RCT*	60-3/4	57-1/4	22	12-1/4	8	50-1/2	14-1/4	50-1/2	4
†GS6 50 XCT*	65-1/2	61	22	13-1/2	8	54-1/4	14-1/4	54-1/4	4
GS6 55 XCT*	59-3/4	55-1/4	24	13-1/2	8	48	14-1/4	48	4
SHORT MODELS									
†GS6 30 ORBS	50	46-1/2	18	12	8	40	N/A	N/A	3 or 4
GS6 30 OCS	50	46-1/2	20	12	8	40	N/A	N/A	3 or 4
†GS6 40 BRBS	51-1/2	48	20	12	8	41-1/4	N/A	N/A	3 or 4
GS6 40 BCS	51-1/2	48	22	12	8	41-1/4	N/A	N/A	3 or 4
GS6 50 BCS	53-1/4	49-3/4	24	12	8	41-3/8	N/A	N/A	3 or 4

Water connection is 3/4" on all models.

*Optional side-mounted recirculating taps, add "L" to the suffix in the model number (GS6 50 RCTL).

† Models ship with supplied insulation blanket.

For 10-year tank and 6-year parts limited warranty, change "6" to "X" in the model number (example: GSX 30 OCT).

All models approved for installation from sea level to 10,100 ft. elevation.

‡ LP models not available on GS6 40 OCT.

PROLINE® MOBILE HOME ATMOSPHERIC VENT



COMPLIES WITH HUD STANDARDS FOR MANUFACTURED HOUSING INSTALLATION

GAS CONTROL CONVERTIBLE FOR NATURAL AND PROPANE GAS

- For flexibility to meet the varying needs of manufactured housing installations.

SIDE-MOUNTED 3/4" COLD WATER INLET

- For ease of installation when cold water supply originates below the structure.
- Top mounted 3/4" hot water outlet.

GREEN CHOICE® GAS BURNER

- Patented eco-friendly burner design reduces NOx emissions by up to 33% and complies with Low-NOx emission requirements of less than 40 ng/l.

COREGARD™ ANODE ROD

BLUE DIAMOND® GLASS COATING

ENHANCED-FLOW BRASS DRAIN VALVE

CODE COMPLIANCE

- Meets UBC, CEC and HUD National Codes.
- Meets the thermal efficiency and standby loss requirements of the U.S. Department of Energy and current edition of ASHRAE/IES 90.1.
- Complies with the Federal Energy Conservation Standards effective April 16, 2015, in accordance with the Energy Policy and Conservation Act (EPCA), as amended.

DESIGN-CERTIFIED BY CSA INTERNATIONAL

- Certified at 300 psi test pressure and 150 psi working pressure.
- Listed according to ANSI Z21.10.1-CSA4.1 standards governing storage tank-type gas water heaters.

CSA CERTIFIED AND ASME RATED T&P RELIEF VALVE

6-YEAR LIMITED TANK AND PARTS WARRANTY

- For complete information, consult written warranty or go to statewaterheaters.com.

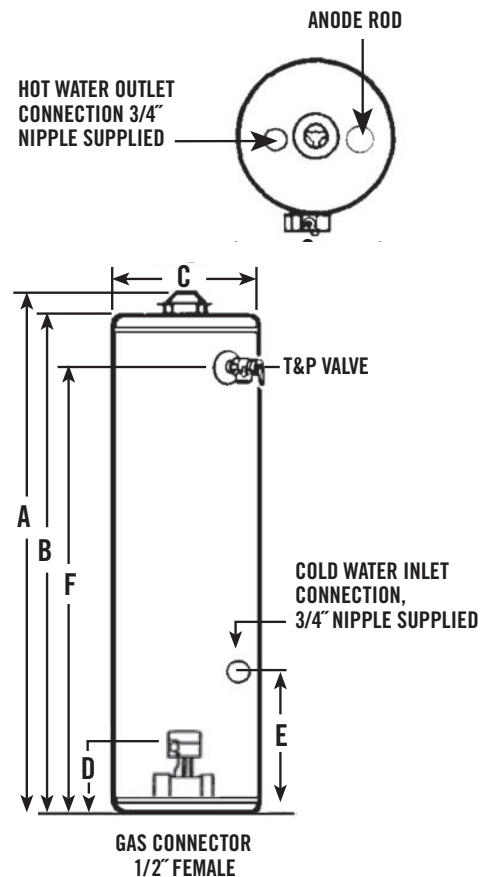

Model Number	Gallon Capacity	First Hour Rating Gallon	Energy Factor	Recovery @ 90°F Rise Gallon Per Hour	Btu Input Per Hour Natural Gas	Btu Input Per Hour Propane	Approx. Shipping Weight (lbs)
GS6 30 MHG	30	55	0.63	36	35,500	32,000	129
GS6 40 MHG	40	62	0.62	36	35,500	32,000	153

Model Number	Dimensions in Inches							
	Insulation	A	B	C	D	E	F	Draft Hood Outlet
GS6 30 MHG	2	61-1/2	58	18	13	14-1/4	52	3 or 4
GS6 40 MHG	2	61-3/4	58-1/4	20	13	14-1/4	51-3/4	3 or 4

All models ship from the factory for use with natural gas, a complete propane (LP) burner is supplied for converting to propane gas.

All models are certified from sea level to 10,100 ft. elevation.

No option available for top T&P.

PROLINE® MOBILE HOME DIRECT VENT



COMPLIES WITH HUD STANDARDS FOR MANUFACTURED HOUSING INSTALLATION GAS CONTROL CONVERTIBLE FOR NATURAL AND PROPANE GAS

- For flexibility to meet the varying needs of manufactured housing installations.

DIRECT VENT MODELS PACKAGE WITH BOTTOM INTAKE AIR VENT

- To draw all combustion make-up air from outside the structure.

OPTIONAL DUCTED AIR INLET KIT FOR DIRECT VENT MODELS

- For use when water heater is installed over a basement.
- Provision for horizontal air inlet ducting.

SIDE-MOUNTED 3/4" COLD WATER INLET GREEN CHOICE® GAS BURNER

- Patented eco-friendly burner design reduces NOx emissions by up to 33% and complies with Low-NOx emission requirements of less than 40 ng/J.

SELF-CLEANING DIP TUBE

COREGARD™ ANODE ROD

ENHANCED-FLOW BRASS DRAIN VALVE

BLUE DIAMOND® GLASS COATING

CODE COMPLIANCE

- Meets UBC, CEC and HUD National Codes.
- Meets the thermal efficiency and standby loss requirements of the U.S. Department of Energy and current edition of ASHRAE/IES 90.1.
- Complies with the Federal Energy Conservation Standards effective April 16, 2015, in accordance with the Energy Policy and Conservation Act (EPCA), as amended.

DESIGN-CERTIFIED BY CSA INTERNATIONAL

- Certified at 300 psi test pressure and 150 psi working pressure.
- Listed according to ANSI Z21.10.1-CSA 4.1 standards governing storage tank-type gas water heaters.

CSA CERTIFIED AND ASME RATED T&P RELIEF VALVE

6-YEAR LIMITED TANK AND PARTS WARRANTY

- For complete information, consult written warranty or go to statewaterheaters.com.

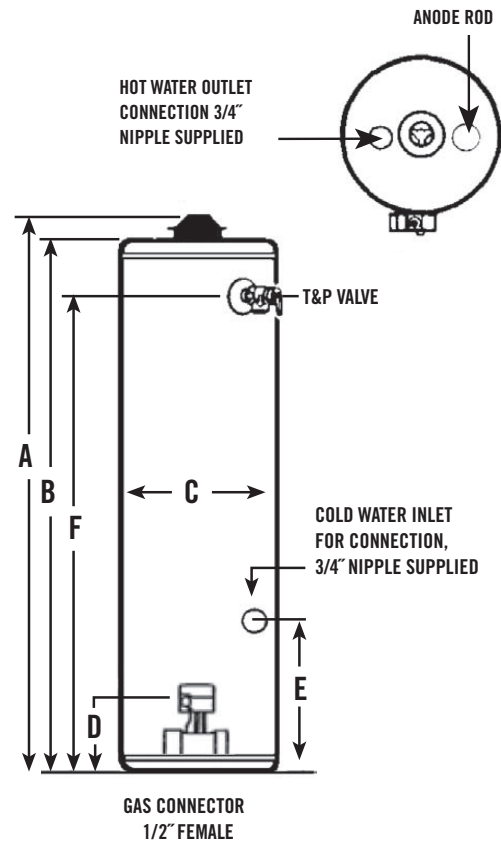

Model Number	Gallon Capacity	First Hour Rating Gallon	Energy Factor	Recovery @ 90°F Rise Gallon Per Hour	Btu Input Per Hour Natural Gas	Btu Input Per Hour Propane	Approx. Shipping Weight (lbs)
GS6 30 MDV	30	49	0.63	31	30,000	29,000	129
GS6 40 MDV	40	61	0.62	33	32,000	29,000	153
GS6 50 MDV	50	77	0.6	39	40,000	37,000	168

Model Number	Dimensions in Inches							
	Insulation	A	B	C	D	E	F	Vent Outlet
GS6 30 MDV	2	61	58	18	13	14-1/4	52-1/2	3
GS6 40 MDV	2	61-3/4	58-3/4	20	13	14-1/4	52-1/4	3
GS6 50 MDV	2	60	57	22	13	14-1/4	50	3

Certified from sea level to 5,400 ft. elevation.

No option available for top T&P.

All models ship from the factory for use with natural gas, a complete propane burner is supplied for converting to propane gas.

Water connection is 3/4" on all models.



**PROLINE®
GOOD**

THE ELECTRONIC GAS CONTROL INCORPORATES AN LED STATUS INDICATOR THAT MONITORS SYSTEM OPERATION AND SERVICE DIAGNOSTICS

HIGH ENERGY FACTORS

- Eco-friendly non-CFC foam insulation, heat traps and specially designed combustion chamber combine to produce a high Energy Factor for maximum savings on operating costs.

GREEN CHOICE® GAS BURNER

- Enhanced Ultra-low NOx burner complies with SCAQMD Rule 1121 and other air quality management districts with similar requirements for NOx emissions of less than 10 ng/J.

SELF-CLEANING DIP TUBE

COREGARD™ ANODE ROD

PUSH-BUTTON PIEZO IGNITOR

HEAT TRAP NIPPLES

BLUE DIAMOND® GLASS COATING

ENHANCED-FLOW BRASS DRAIN VALVE

CODE COMPLIANCE

- Meets UBC, CEC and HUD National Codes.
- Meets the thermal efficiency and standby loss requirements of the U.S. Department of Energy and current edition of ASHRAE/IES 90.1.
- Complies with the Federal Energy Conservation Standards effective April 16, 2015, in accordance with the Energy Policy Conservation Act (EPCA), as amended.

DESIGN-CERTIFIED BY CSA INTERNATIONAL

- Certified at 300 psi test pressure and 150 psi working pressure.
- Listed according to ANSI Z21.10.1-CSA 4.1 standards governing storage tank-type gas water heaters.

6-YEAR LIMITED TANK AND PARTS WARRANTY

- For complete information, consult written warranty or go to statewaterheaters.com.

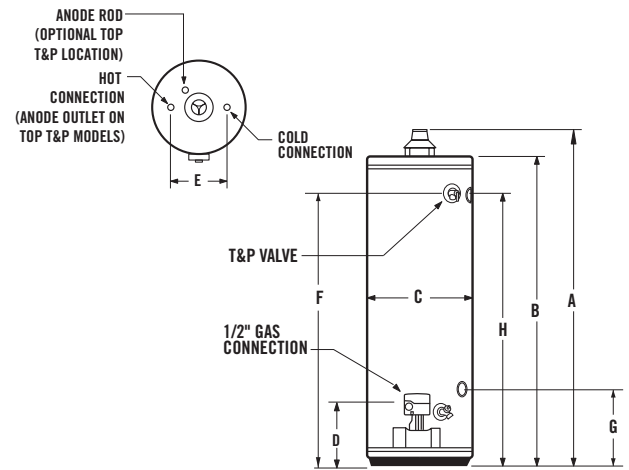

Maximum Hydrostatic Working Pressure: 150 PSI

Model Number	Gallon Capacity	First Hour Rating Gallon	Energy Factor	Recovery @ 90° Rise Gallon Per Hour	BTU Input Per Hour Natural Gas	Approx. Shipping Weight (lbs)
TALL MODELS						
GS6 30 ORUT	30	55	0.63	34	33,000	126
GS6 40 BRUT	40	71	0.62	41	40,000	125
GS6 40 BCUT	40	71	0.63	41	40,000	125
GS6 50 BRUT	50	91	0.6	42	40,000	148
GS6 50 BCUT	50	91	0.62	42	40,000	148
GS6 50 RCUT*	50	98	0.6	51	50,000	177
SHORT MODELS						
GS6 40 BCUS	40	69	0.62	41	40,000	138

Model Number	Dimensions in Inches								
	A	B	C	D	E	F	G*	H*	Draft Hood
TALL MODELS									
GS6 30 ORUT	61-3/4	58	16	12	8	51-3/4	N/A	N/A	3 or 4
GS6 40 BRUT	62	58-1/4	18	12	8	52	N/A	N/A	3 or 4
GS6 40 BCUT	62	58-1/4	20	12	8	52	N/A	N/A	3 or 4
GS6 50 BRUT	60-3/4	57-1/4	20	12	8	50-1/2	N/A	N/A	3 or 4
GS6 50 BCUT	60-3/4	57-1/4	22	12	8	50-1/2	N/A	N/A	3 or 4
GS6 50 RCUT*	61	57-1/2	22	12-1/4	8	50-1/2	12-1/4	50-1/2	4
SHORT MODELS									
GS6 40 BCUS	51-1/2	47-3/4	22	12	8	41-1/4	N/A	N/A	3 or 4

All models may be ordered from the factory with top T&P valve as an option by adding "G" to the suffix of the model number (example GS6 30 ORUTG).

*Side loop connections are standard on model GS6 50 RCUT.

Most models approved for installation from sea level to 7,700 ft. elevation (except GS6 50 RCUT, approved to 5,400 ft.). For 10-year tank and 6-year parts limited warranty, change "6" to "X" in the model number (example: GSX 30 ORUT).



FLAMMABLE VAPOR RESISTANT/DIRECT VENT SEALED COMBUSTION SYSTEM

DURABLE, ULTRA-LOW NO_x BURNER CONSTRUCTION

NON-CFC FOAM INSULATION

- The tank is surrounded by a thick coat of non-CFC polyurethane foam to trap heat inside the tank, saving energy.

¾" TOP WATER CONNECTIONS AND SIDE SPACE HEATING CONNECTIONS

½" GAS CONNECTION

COREGARD™ ANODE ROD

BLUE DIAMOND® GLASS COATING

ENHANCED-FLOW BRASS DRAIN VALVE

GREEN CHOICE® GAS BURNER

- Complies with SCAQMD Rule 1121 and other air quality management districts with similar requirements for NO_x emissions of less than 10 ng/J.

CODE COMPLIANCE

- Meets UBC, CEC and HUD National Codes.
- Meets the thermal efficiency and standby loss requirements of the U.S. Department of Energy and current edition of ASHRAE/IES 90.1.
- Complies with the Federal Energy Conservation Standards effective April 16, 2015, in accordance with the Energy Policy and Conservation Act (EPCA), as amended.
- DESIGN-LISTED BY CSA INTERNATIONAL**
- Certified at 300 psi test pressure and 150 psi working pressure.
- Listed according to ANSI Z21.10.1-CSA 4.1 standards governing storage tank-type gas water heaters.

CSA CERTIFIED AND ASME RATED T&P RELIEF VALVE

6-YEAR LIMITED TANK AND PARTS WARRANTY

- For complete information, consult written warranty or go to statewaterheaters.com.

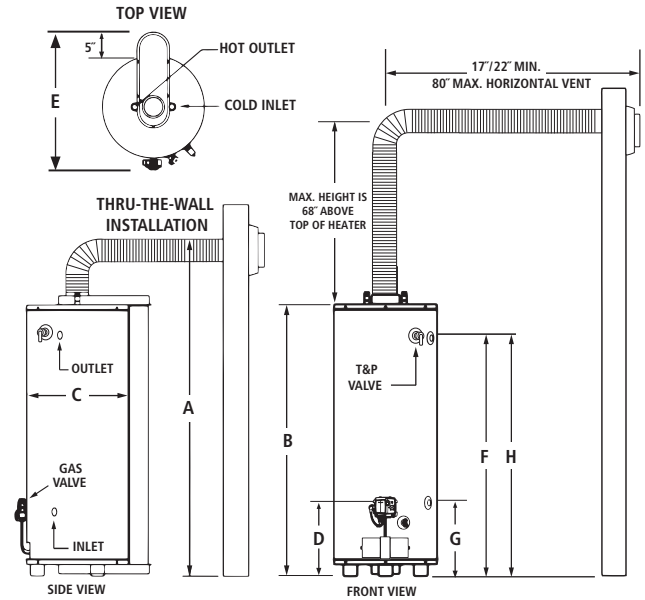

Model Number	Gallon Capacity	First Hour Rating Gallon	Energy Factor	Recovery @ 90°F Rise Gallon Per Hour	BTU Input Per Hour	Approx. Shipping Weight (lbs)
GS6 40 UBDS L	40	59	0.62	39	36,000	179
GS6 50 UBDT L	50	81	0.62	41	38,000	193

Model Number	Dimensions in Inches								
	Concentric Vent Connection	A	B	C	D	E	F	G	H
GS6 40 UBDS L	3 or 5	65-1/4	50-1/2	22	13-1/2	30	43-7/8	15	45
GS6 50 UBDT L	3 or 5	58-1/2	73-1/2	22	13-1/2	30	52-1/4	15	53

No option available for top T&P valve.
 All models have ¾" top water connections and comes standard with side loop fittings.
 All models are certified from sea level to 7,700 ft. elevation.

PROLINE® ULTRA-LOW NO_x HIGH RECOVERY



FULLY AUTOMATIC CONTROLS WITH SAFETY SHUTOFF

HEAVY GAUGE STEEL JACKET

BLUE DIAMOND® GLASS COATING

FOAM INSULATION

ULTRA-LOW NO_x EMISSIONS

- Complies with SCAQMD Rule 1146.2 and other Air Quality Management Districts with similar requirements of 14 ng/J or 20 ppm.

EASY-TO-INSTALL

- Completely factory-assembled. Only gas, water and vent connections need to be made. All connections are located in front and top of heaters for ease-of-installation and service.

COREGARD™ ANODE ROD

- Our anode rods have a stainless steel core that extends the life of the anode rod, allowing superior tank protection far longer than standard anode rods.

MAXIMUM WORKING PRESSURE

- 150 psi.

MAXIMUM GAS INLET PRESSURE

- 14" W.C.

CODE COMPLIANCE

- Meets UBC, CEC and ICC National Codes.
- The Ultra-Low NO_x atmospheric vent residential gas water heater meets the thermal efficiency and standby loss requirements of the U.S. Department of Energy and Current Edition ASHRAE/IES 90.1.

6-YEAR LIMITED TANK AND PARTS WARRANTY

- For complete information, consult written warranty or go to statewaterheaters.com.

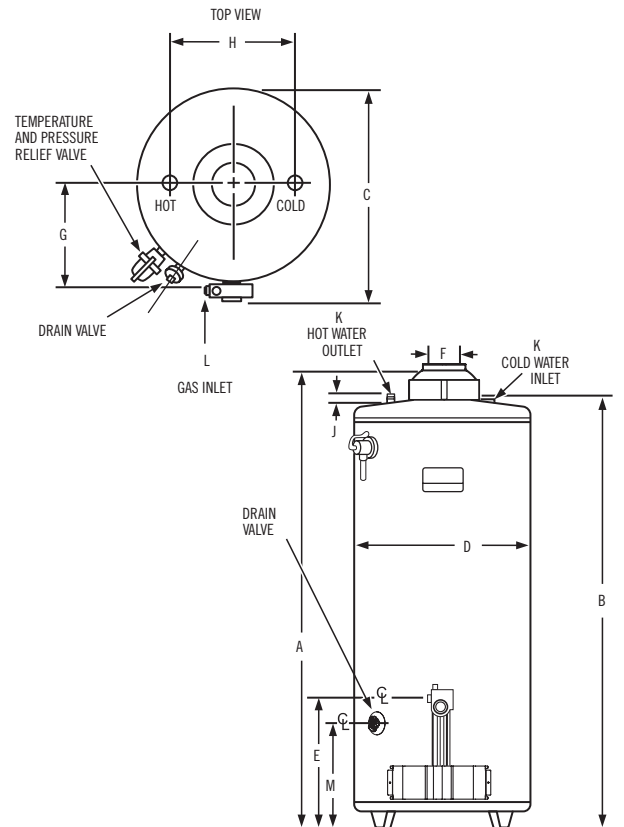

Model Number	Gallon Capacity	Recovery at 90°F Rise Gallon Per Hour	BTU Input Per Hour	Approx. Shipping Weight
†GS6-75-URRS	74	81	75,100	285 lbs
GS6-100-URRT	98	82	75,100	350 lbs

Dimensions in Inches						
Model Number	A	B	C	D	E	F
†GS6-75-URRS	62-1/16	58	29-1/2	25-1/4	15-7/8	4
GS6-100-URRT	70-1/2	66-1/2	30-15/16	27-3/4	15-3/16	4

Dimensions in Inches						
Model Number	G	H	J	K	L	M
†GS6-75-URRS	15-1/4	16	2	1	1/2	12-1/2
GS6-100-URRT	15-3/4	16	1-1/4	1-1/4	1/2	11-15/16

*Recovery rating based on 81% thermal efficiency

**Recovery rating based on 80% thermal efficiency

†The GS6-75-URRS comes standard with side loop fittings for use with hydronic heating applications

PROLINE® XE HYBRID ELECTRIC HEAT PUMP WATER HEATER



PROLINE® XE
BEST



10-YEAR
WARRANTY



INCREASED ENERGY EFFICIENCY

- Reduce water heating costs up to 71% compared to a standard electric water heater.
- Up to a 3.24 Energy Factor (EF) Rating conserves energy and meets ENERGY STAR® qualifications.

DUAL VOLTAGE CAPABLE

- 208/240 VAC 60Hz capable for use in almost any residential application.

CHOICE OF OPERATING MODES

- Select from Efficiency, Hybrid, or Electric modes to match heating requirements to environmental conditions and hot water demand. Hybrid mode automatically adjusts between compressor and element, depending upon heat requirements.
- Vacation mode reduces operating costs and provides freeze protection during extended absence.

BACKUP ELECTRIC ELEMENTS

- Long-lasting 4500W backup heating elements help heat water according to environmental conditions, demand and the chosen operating mode.

DRY FIRE PROTECTION

- Control system ensures the tank is full of water during start up to prevent dry firing the heating elements.

ELECTRONIC USER INTERFACE

- User-friendly electronic interface allows easy control of temperature setting, operating mode, and communicates diagnostics.
- Advanced diagnostics convey error messages for service purposes. The last four error messages are saved in the control system memory.

OTHER FEATURES

- Ideal for basements or garage installations; the compressor transfers heat to the water while dehumidifying and cooling the ambient air.
- Washable air filter is easily removed for routine cleaning.
- Accessory Inlet/Outlet Duct Kit (Part number 100234320)

10-YEAR LIMITED TANK AND PARTS WARRANTY

- For complete information, consult written warranty or go to statewaterheaters.com.

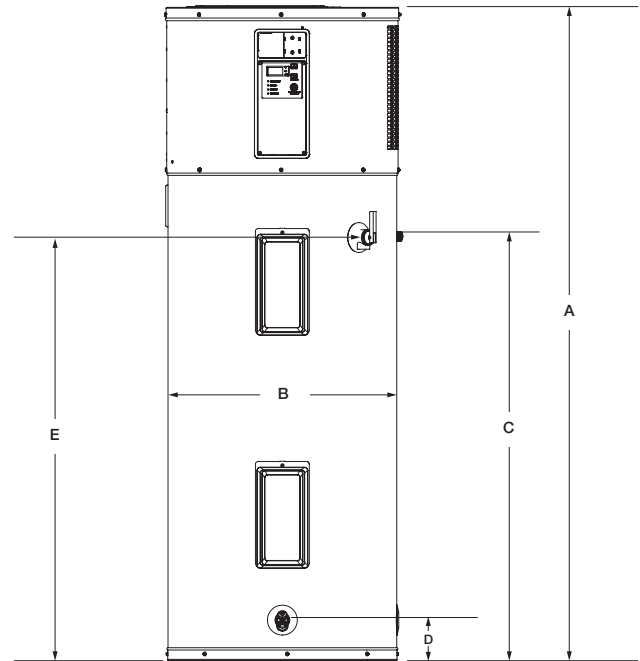

Model Number	Gallon Capacity	Energy Factor by Mode			1st Hour Rating (Gal) By Mode		
		Efficiency	Hybrid	Electric	Efficiency	Hybrid	Electric
HPX 50 DHPTNE	50	3.61	3.24	0.93	44.4	70	57.3
HPX 66 DHPTNE	66	3.44	3.17	0.92	62.5	80	78.6
HPX 80 DHPTNE	80	3.27	3.06	0.92	76.3	95	90.1

Model Number	Dimensions in Inches					Approx. Shipping Weight (lbs)
	A	B	C	D	E	
HPX 50 DHPTNE	63	22	40-5/8	3-3/4	40-1/2	196
HPX 66 DHPTNE	61	27	38	4	38	289
HPX 80 DHPTNE	69	27	46	4	46	307

Requires 30 amp breaker.

Top T&P option not available on these models.

PROLINE® XE HYBRID ELECTRIC HEAT PUMP WATER HEATER



PROLINE® XE
BEST



6-YEAR
6
WARRANTY

INCREASED ENERGY EFFICIENCY

- Reduce water heating costs up to 71% compared to a standard electric water heater.
- Up to a 3.24 Energy Factor (EF) Rating conserves energy and meets ENERGY STAR® qualifications.

DUAL VOLTAGE CAPABLE

- 208/240 VAC 60Hz capable for use in almost any residential application.

CHOICE OF OPERATING MODES

- Select from Efficiency, Hybrid, or Electric modes to match heating requirements to environmental conditions and hot water demand. Hybrid mode automatically adjusts between compressor and element, depending upon heat requirements.
- Vacation mode reduces operating costs and provides freeze protection during extended absence.

BACKUP ELECTRIC ELEMENTS

- Long-lasting 4500W backup heating elements help heat water according to environmental conditions, demand and the chosen operating mode.

DRY FIRE PROTECTION

- Control system ensures the tank is full of water during start up to prevent dry firing the heating elements.

ELECTRONIC USER INTERFACE

- User-friendly electronic interface allows easy control of temperature setting, operating mode, and communicates diagnostics.
- Advanced diagnostics convey error messages for service purposes. The last four error messages are saved in the control system memory.

OTHER FEATURES

- Ideal for basements or garage installations; the compressor transfers heat to the water while dehumidifying and cooling the ambient air.
- Washable air filter is easily removed for routine cleaning.
- Accessory Inlet/Outlet Duct Kit (Part number 100234320)

6-YEAR LIMITED TANK AND PARTS WARRANTY

- For complete information, consult written warranty or go to statewaterheaters.com.

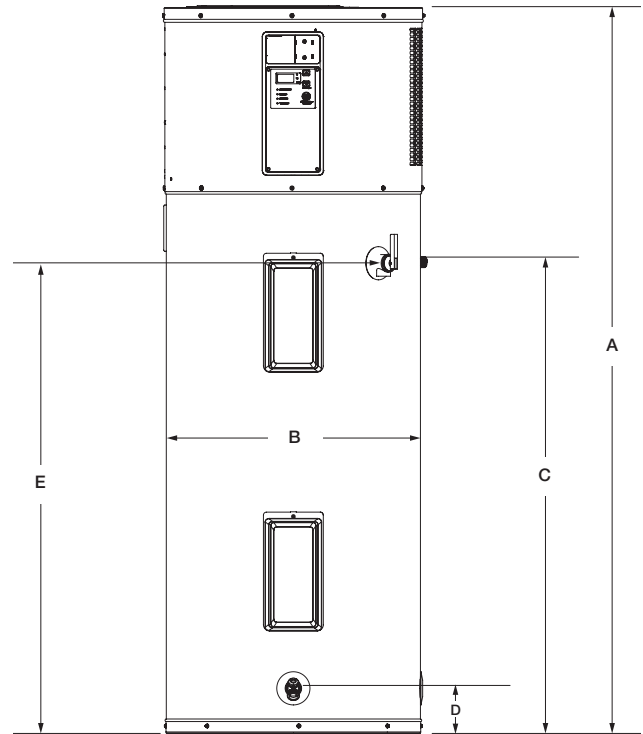

Model Number	Gallon Capacity	Energy Factor by Mode			1st Hour Rating (Gal) By Mode		
		Efficiency	Hybrid	Electric	Efficiency	Hybrid	Electric
HP6 50 DHPT	50	3.61	3.24	0.93	44.4	70	57.3
HP6 60 DHPT	66	3.44	3.17	0.92	62.5	80	78.6
HP6 80 DHPT	80	3.27	3.06	0.92	76.3	95	90.1

Model Number	Dimensions in Inches					Approx. Shipping Weight (lbs)
	A	B	C	D	E	
HP6 50 DHPT	63	22	40-5/8	3-3/4	40-1/2	196
HP6 60 DHPT	61	27	38	4	38	289
HP6 80 DHPT	69	27	46	4	46	307

Requires 30 amp breaker.
Top T&P option not available on these models.

PROLINE® XE ELECTRONIC DISPLAY



PROLINE® XE
BEST



ELECTRONIC USER INTERFACE

- Touchscreen display.
- Multiple operating modes help save money.
 - Energy Saver and vacation modes available.
- Diagnostic feedback.
- Dry fire protection.
- Grid management capable, requires optional CEA-2045 Bridge module.

ENHANCED HEATING ELEMENTS

- Dual 5500 watt elements for the fastest recovery and reliable operation.
- Incoloy stainless steel elements last longer than standard copper elements.

ENHANCED-FLOW BRASS DRAIN VALVE

CODE COMPLIANCE

- Meets UBC, CEC and HUD National Codes.
- Meets the thermal efficiency and standby loss requirements of the U.S. Department of Energy and current edition of ASHRAE/IES 90.1.
- Complies with the Federal Energy Conservation Standards effective April 16, 2015, in accordance with the Energy Policy and Conservation Act (EPCA), as amended.

APPROVED FOR MANUFACTURED HOUSING

- All residential electric water heaters are compliant with HUD standards for mobile homes/manufactured housing.

DESIGN-LISTED BY UNDERWRITERS LABORATORIES

- Certified at 300 psi test pressure and 150 psi working pressure.
- Listed according to UL174 standards governing storage tank-type water heaters.

10-YEAR LIMITED TANK AND PARTS WARRANTY

- For complete information, consult written warranty or go to statewaterheaters.com.

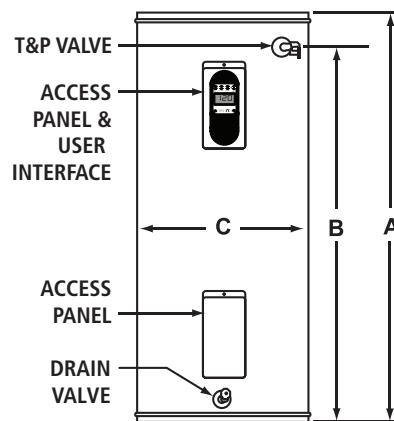
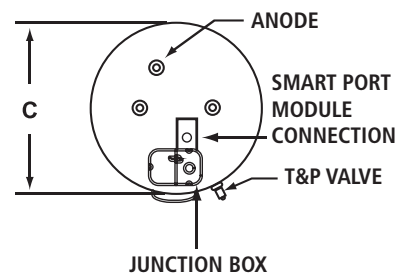

Model Number	Gallon Capacity	First Hour Rating Gallon	Energy Factor	Recovery @ 90°F Rise Gallon Per Hour	Approx. Shipping Weight (lbs)
Tall Models					
ENX 40 DXRT	40	61	0.95	25	118
ENX 50 DXRT	50	79	0.95	25	134
ENX 55 DXRT	55	79	0.94	25	145
Short Models					
ENX 40 DXRS	40	56	0.95	25	109
ENX 50 DXRS	50	58	0.95	25	161

Model Number	Element Wattage 240V		Dimensions in Inches		
	Standard	Maximum	A	B	C
Tall Models					
ENX 40 DXRT	5500	6000	60-1/4	53-1/4	20
ENX 50 DXRT	5500	6000	60-1/2	51-1/4	22
ENX 55 DXRT	5500	6000	56-1/2	48-1/2	24
Short Models					
ENX 40 DXRS	5500	6000	50	40-3/4	22
ENX 50 DXRS	5500	6000	49-3/4	40-1/4	24

3/4" water connections on 8" center.

Top-mounted T&P valve not available.

Only available for 240V or 208V applications.

Equipped as dual element only, no single element configurations available.

PROLINE® MASTER



PROLINE® MASTER
BETTER



COMMERCIAL-GRADE HEATING ELEMENTS

- Dual 4500 watt elements for faster recovery and reliable operation.
- Long-lasting dual stainless steel elements last longer than standard copper elements.

HIGH ENERGY FACTORS

SELF-CLEANING DIP TUBE

COREGARD™ ANODE ROD

- ProLine® Master products have increased anode protection with either longer, or multiple anodes depending on model.

CODE COMPLIANCE

- Meets UBC, CEC and HUD National Codes.
- Meets the thermal efficiency and standby loss requirements of the U.S. Department of Energy and current edition of ASHRAE/IES 90.1.
- Complies with the Federal Energy Conservation Standards effective April 16, 2015, in accordance with the Energy Policy and Conservation Act (EPCA), as amended.

APPROVED FOR MANUFACTURED HOUSING

- All residential electric water heaters are compliant with HUD standards for mobile homes/manufactured housing.

DESIGN-LISTED BY UNDERWRITERS LABORATORIES

- Certified at 300 psi test pressure and 150 psi working pressure.
- Listed according to UL174 standards governing storage tank-type water heaters.

6-YEAR LIMITED TANK AND PARTS WARRANTY

- For complete information, consult written warranty or go to statewaterheaters.com.

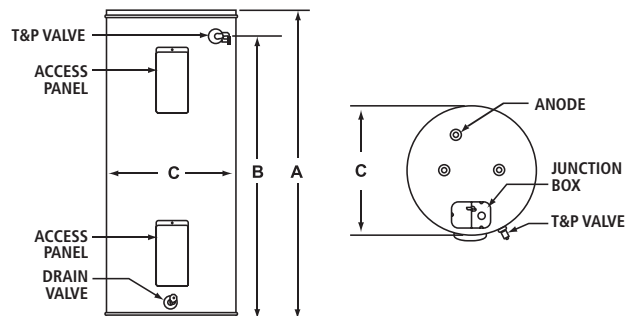

Model Number	Gallon Capacity	First Hour Rating Gallon	Energy Factor	Recovery @ 90°F Rise Gallon Per Hour	Approx. Shipping Weight (lbs)
Tall Models					
EN8 40 DORT	40	50	0.95	21	118
EN8 50 DORT	50	73	0.95	21	125
EN8 55 DORT	55	76	0.94	21	145
Short Models					
EN8 40 DORS	40	55	0.95	21	109
EN8 50 DORS	50	62	0.95	21	161

Model Number	Element Wattage 240V		Dimensions in Inches		
	Standard	Maximum	A	B	C
Tall Models					
EN8 40 DORT	4500	6000	61-1/2	53-1/4	18
EN8 50 DORT	4500	6000	60-1/2	51-1/4	20-1/2
EN8 55 DORT	4500	6000	56-1/2	48-1/2	24
Short Models					
EN8 40 DORS	4500	6000	50	40-3/4	20-1/2
EN8 50 DORS	4500	6000	49-3/4	40-3/8	23

3/4" water connections on 8" center.



ENHANCED HEATING ELEMENTS

- Dual 4500 watt elements for faster recovery and reliable operation.
- Incoloy stainless steel lower element lasts longer than a standard copper element.

HIGH ENERGY FACTORS

SELF-CLEANING DIP TUBE

COREGARD™ ANODE ROD

- Increased anode protection with either longer or multiple anodes depending on model.

LONG-LASTING STAINLESS STEEL UPPER AND LOWER ELEMENTS

CODE COMPLIANCE

- Meets UBC, CEC and HUD National Codes.
- Meets the thermal efficiency and standby loss requirements of the U.S. Department of Energy and current edition of ASHRAE/IES 90.1.
- Complies with the Federal Energy Conservation Standards effective April 16, 2015, in accordance with the Energy Policy and Conservation Act (EPCA), as amended.

APPROVED FOR MANUFACTURED HOUSING

- All residential electric water heaters are compliant with HUD standards for mobile homes/manufactured housing.

DESIGN-LISTED BY UNDERWRITERS LABORATORIES

- Certified at 300 psi test pressure and 150 psi working pressure.
- Listed according to UL174 standards governing storage tank-type water heaters.

8-YEAR LIMITED TANK AND PARTS WARRANTY

- For complete information, consult written warranty or go to statewaterheaters.com.

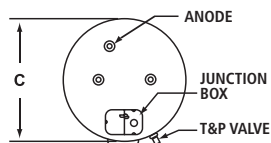
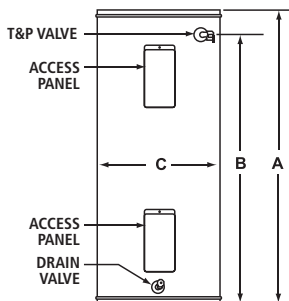

Model Number	Gallon Capacity	First Hour Rating Gallon	Energy Factor	Recovery @ 90°F Rise Gallon Per Hour	Approx. Shipping Weight (lbs)
Tall Models					
†EN6 30 DORT	30	47	0.95	21	95
†EN6 40 DORT	40	51	0.95	21	118
†EN6 50 DORT	50	73	0.95	21	125
†EN6 55 DORT	55	76	0.94	21	145
Short Models					
EN6 30 DOBS*	30	48	0.95	21	95
†EN6 30 DORS	30	49	0.95	21	94
†EN6 40 DORS	40	55	0.95	21	109
†EN6 50 DORS	50	62	0.95	21	161
Lowboy Top Connect Models					
EN6 20 SOLS	19.5	N/A	N/A	21	65
EN6 30 DOLBS*	28	40	0.95	21	90
†EN6 30 DOLS	28	43	0.95	21	115
EN6 40 DOLBS*	38	44	0.95	21	118
†EN6 36 DOLS	36	46	0.95	21	118
†EN6 50 DOLBS*	48	57	0.95	21	172

Model Number	Element Wattage 240V		Dimensions in Inches		
	Standard	Maximum	A	B	C
Tall Models					
†EN6 30 DORT	4500	6000	46-1/2	39-1/2	19
†EN6 40 DORT	4500	6000	60-1/4	53-1/4	18
†EN6 50 DORT	4500	6000	60-1/2	51-1/4	20-1/2
†EN6 55 DORT	4500	6000	56-1/2	48-1/2	24
Short Models					
EN6 30 DOBS*	4500	6000	39	30-1/2	20
†EN6 30 DORS	4500	6000	39-3/4	30-1/2	22
†EN6 40 DORS	4500	6000	49-3/4	40-3/4	20-1/2
†EN6 50 DORS	4500	6000	49-1/4	40-3/8	23
Lowboy Top Connect Models					
EN6 20 SOLS	4500	6000	30	21-1/4	20
EN6 30 DOLBS*	4500	6000	30	21-3/4	20
†EN6 30 DOLS	4500	6000	30	21-3/4	22
EN6 40 DOLBS*	4500	6000	32	24	23
†EN6 36 DOLS	4500	6000	32	24	24
†EN6 50 DOLBS*	4500	6000	34	25	26-1/2

3/4" water connections on 8" center.

EN6 20 SOLS is a single element configuration only.

*Models ship with supplied insulation blanket.

†For 10-year tank and 6-year parts limited warranty, change "N6" to "SX" in select models and "R" to "N" in select model number (example: ESX 40 DONT).

Top T&P option not available on 10-year lowboy models.



APPROVED FOR MANUFACTURED HOUSING

- All residential electric water heaters are compliant with HUD Standards for mobile homes/manufactured housing.

SIDE WATER CONNECTIONS

- For ease of installation in mobile home applications.

COREGARD™ ANODE ROD

- Our anode rods have a stainless steel core that extends the life of the anode rod allowing superior tank protection far longer than standard anode rods.

LONG-LASTING HEATING ELEMENTS

- Screw-in, direct immersion, 3500W/240V or 3000W/120V heating elements for maximum efficiency.

BLUE DIAMOND® GLASS COATING

ENHANCED-FLOW BRASS DRAIN VALVE

- Our residential water heaters have a solid brass, tamper resistant, enhanced-flow, ball type, drain valve.
- Uses a standard female hose fitting that allows for fast and easy draining during maintenance.

CSA CERTIFIED AND ASME RATED T&P RELIEF VALVE

CODE COMPLIANCE

- Meets UBC, CEC and HUD National Codes.
- Meets the thermal efficiency and standby loss requirements of the U. S. Department of Energy and current edition of ASHRAE/IES 90.1.
- Complies with the Federal Energy Conservation Standards effective April 16, 2015, in accordance with the Energy Policy and Conservation Act (EPCA), as amended.

DESIGN-LISTED BY UNDERWRITERS LABORATORIES

- Certified at 300 psi test pressure and 150 psi working pressure.
- Listed according to UL174 standards governing storage tank-type water heaters.

6-YEAR LIMITED TANK AND PARTS WARRANTY

- For complete information, consult written warranty or go to statewaterheaters.com.

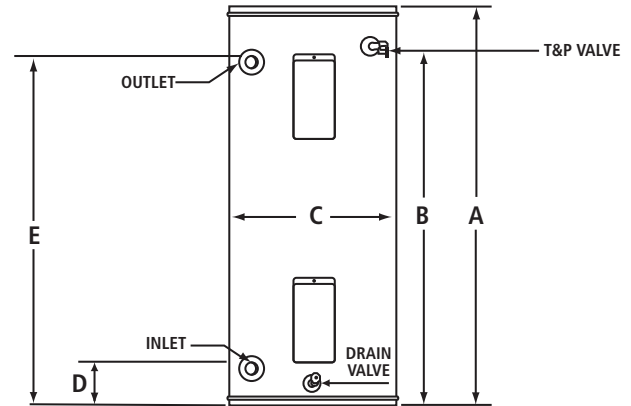
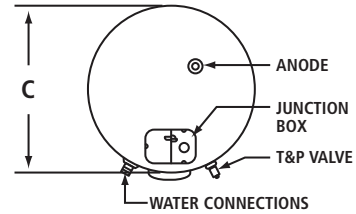

Model Number	Gallon Capacity	First Hour Rating Gallon	Energy Factor	Recovery @ 90°F Rise Gallon Per Hour	Voltage	Approx. Shipping Weight (lbs)
MHE6-30H-030D	30	42	0.95	14	120	98
MHE6-30H-035D	30	42	0.95	16	240	98
MHE6-40R-030D	40	51	0.95	14	120	109
MHE6-40R-035D	40	51	0.95	16	240	109
MHE6-30L-030D*	28	40	0.95	14	120	96
MHE6-30L-035D*	28	40	0.95	16	240	96

Model Number	Wattage		Dimensions in Inches				
	Upper Element	Lower Element	A	B	C	D	E
MHE6-30H-030D	3000	3000	46-3/4	39-1/2	19	3-7/8	39-5/8
MHE6-30H-035D	3500	3500	46-3/4	39-1/2	19	3-7/8	39-5/8
MHE6-40R-030D	3000	3000	50	40-3/4	22	4-3/8	41
MHE6-40R-035D	3500	3500	50	40-3/4	22	4-3/8	41
MHE6-30L-030D*	3000	3000	30	21-3/4	22	4-1/2	22
MHE6-30L-035D*	3500	3500	30	21-3/4	22	4-1/2	22

*Models ship with supplied insulation blanket.

MHE6 models may have limited element options due to element size or other restrictions.

3/4" water connections

Available with side T&P only.



Table Top



Point-Of-Use



Compact



Lowboy



APPROVED FOR MANUFACTURED HOUSING

All residential electric water heaters are compliant with HUD standards for mobile homes/ manufactured housing.

TABLE TOP

- Features a convenient flat porcelain surface at 36" height, providing extra "counter space" wherever installed. All plumbing and electrical connections are made through the back of the water heater. This heater is equipped with a PEX cross-linked polymer dip tube.

POINT-OF-USE

- Designed for low-demand, such as office lavatories or buildings with remote restrooms.

COMPACT

- Side-mounted plumbing and electrical connections (optional top-mounted water connections for field conversion). Designed for installation under a counter, in a crawl space or in other tight spaces.

ENHANCED-FLOW BRASS DRAIN VALVE

CODE COMPLIANCE

- Meets UBC, CEC and HUD National Codes.
- Meets the thermal efficiency and standby loss requirements of the U.S. Department of Energy and current edition of ASHRAE/IES 90.1.
- Complies with the Federal Energy Conservation Standards effective April 16, 2015, in accordance with the Energy Policy and Conservation Act (EPCA), as amended.

DESIGN-LISTED BY UNDERWRITERS LABORATORIES

- Certified at 300 psi test pressure and 150 psi working pressure.
- Listed according to UL174 standards governing storage tank-type water heaters.

6-YEAR LIMITED TANK AND PARTS WARRANTY

- For complete information, consult written warranty or go to statewaterheaters.com.

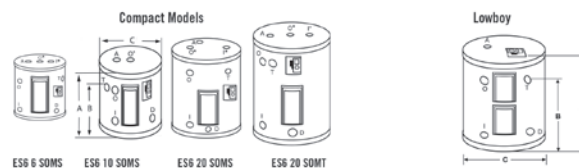

Inst	Drain	Plug/Inlet
Outlet	T&P	Plug/Outlet

Table Top Model

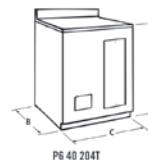

Point-Of-Use

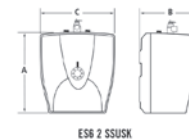

Model Number	Gallon Capacity	First Hour Rating Gallon	Energy Factor	Approx. Shipping Weight (lbs)
COMPACT MODELS				
ES6 6 SOMS K	6	N/A	N/A	35
ES6 10 SOMS K	10	N/A	N/A	41
ES6 20 SOMS K	19	N/A	N/A	68
ES6 20 SOMT K	19.9	N/A	N/A	68
LOWBOY SIDE-CONNECT MODEL				
EN6 30 DOMBS*	28	39	0.95	101
EN6 30 DOMS	28	39	0.95	115
EN6 40 DOMBS*	38	47	0.95	118
EN6 40 DOMS	38	44	0.95	118
TABLE TOP MODEL				
EN6 38 20TT	38	45	0.88	150
POINT-OF-USE MODELS				
ES6 2 SSUS K	2.5	N/A	N/A	20

Model Number	Element Wattage		Recovery @ 90°F Rise Gallons Per Hour	Dimensions in Inches		
	Standard	Maximum		A	B	C
COMPACT MODELS						
	120V	240V				
ES6 6 SOMS K	1650	3000	8	15-1/4	10-3/4	14-1/4
ES6 10 SOMS K	1650	6000	8	18-1/4	12-1/4	16
ES6 20 SOMS K	2500	6000	11	24-3/4	18-5/8	18
ES6 20 SOMT K	2500	6000	11	31-5/8	25-3/4	16
LOWBOY SIDE-CONNECT MODEL						
	240V					
EN6 30 DOMBS*	4500	6000	21	30	21-3/4	22
EN6 30 DOMS	4500	6000	21	31-1/4	21-3/4	24
EN6 40 DOMBS*	4500	6000	21	31-3/4	24	24
EN6 40 DOMS	4500	6000	21	33-1/2	24	26
TABLE TOP MODEL						
	240V					
EN6 38 20TT	4500	5500	21	36	24	25
POINT-OF-USE MODELS						
	120V					
ES6 2 SSUS K	1500 @ 120V		7	13-3/4	11	13-3/4

*Models ship with supplied insulation blanket.



SPMD Series – Pre-Pressurized Diaphragm Tanks

2 THROUGH 119-GALLON CAPACITIES IN FREE-STANDING, IN-LINE OR HORIZONTAL DESIGNS

DURABLE BUTYL RUBBER PARABOLIC DIAPHRAGM

POWDER COATED LINING BONDED TO TANK SHELL, PROTECTS AGAINST RUST

ROTATING CORROSION-RESISTANT BASE ON FREE-STANDING MODELS ASSURES STABILITY

TANKS ARE CERTIFIED TO NSF/ANSI STANDARD 61-G AND 372 LISTED AND ARE IN COMPLIANCE WITH CALIFORNIA AND VERMONT'S NO-LEAD LEGISLATION

5-YEAR LIMITED WARRANTY

- For complete information, consult written warranty or go to statewaterheaters.com.

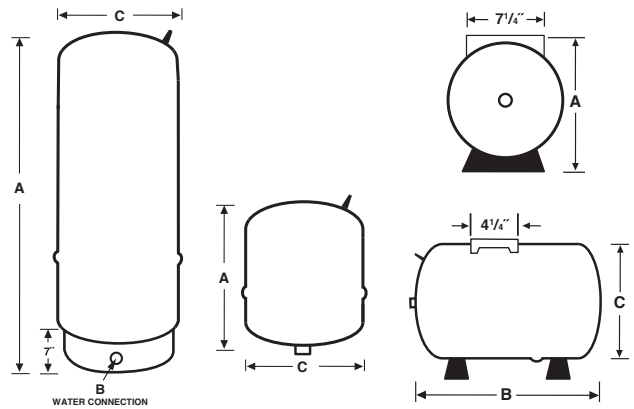

SSB Series – Pre-Pressurized Diaphragm Tanks

2 THROUGH 119-GALLON CAPACITIES IN FREE-STANDING, IN-LINE OR HORIZONTAL DESIGNS

DURABLE BUTYL RUBBER PARABOLIC DIAPHRAGM

POWDER COATED LINING BONDED TO TANK SHELL, PROTECTS AGAINST RUST

TANKS ARE CERTIFIED TO NSF/ANSI STANDARD 61-G AND 372 LISTED AND ARE IN COMPLIANCE WITH CALIFORNIA AND VERMONT'S NO-LEAD LEGISLATION

Rust-Guard NO-WELD STEEL BASE

5-YEAR LIMITED WARRANTY

- For complete information, consult written warranty or go to statewaterheaters.com.



	Model Number	Volume (Gallons)	Dimensions in Inches			Weight (lbs)
			"A" Overall Height	"B" To Center of Water Inlet	"C" Diameter	
SPMD Series Free Standing Plastic Base	SPMD-14	14	24-3/4	2-1/4	15-3/8	25.5
	SPMD-20	20	32-3/4	2-1/4	15-3/8	30
	SPMD-31	31	45-1/2	2-1/4	15-3/8	40
	SPMD-36S	36	32-3/8	2-1/4	20	45
	SPMD-52	52	38-5/8	2-1/4	23-3/8	77
	SPMD-86	86	59	2-1/4	23-3/8	105
	SPMD-96	96	63-3/8	2-1/4	23-3/8	111
	SPMD-119	119.5	61-1/4	2-1/2	26	165
SSB Series Free Standing Metal Base	SSB20	20	32-3/4	2-1/4	15-3/8	30
	SSB32	32	45-1/2	2-1/4	15-3/8	40
	SSB36	36	32-3/8	2-1/4	20	45
	SSB52	52	38-5/8	2-1/4	23-3/8	77
	SSB65	65	46-5/8	2-1/4	23-3/8	87
	SSB86	86	59	2-1/4	23-3/8	105
	SSB119	119.5	61-1/4	2-1/2	26	165
	SPMDI Series In-Line	SPMDI-2	2	10-3/16	–	8-1/4
SPMDI-5		4.6	14-3/4	–	11	9
SPMDI-7		7.3	21-1/16	–	11	14
SPMDI-14		14	23-1/2	–	15-3/8	25
SPMDH Series Horizontal				"B" Overall Length		
	SPMDH-7	7.3	12-7/8	21-1/8	11	16
	SPMDH-14	14	17-3/8	21-3/4	15-3/8	25.5
	SPMDH-20	20	17-3/8	27-1/8	15-3/8	30

1" Female connection on 14, 20, and 36S gallons.

1-1/4" Female connections on 52, 86, 96, and 119 gallons.

SPMDI connection 3/4" Male. *SPMDI-14 1" male

SPMDH-7 connection 3/4" Male. *SPMDH-14, SPMDH-20 connection 1" Male

HEAVY-DUTY STATE PROLINE® GLASSLINED



Heavy-Duty Glasslined G Series

5-YEAR LIMITED WARRANTY

- UL Certified.
- Max working pressure is 125 psig.
- Anodic Protection.
- For complete information, consult written warranty or go to statewaterheaters.com.

G SERIES GLASSLINED PUMP TANKS

Model Number	Volume (Gallons)	Dimensions in Inches						Weight (lbs)
		A	B	C	D	E	F	
G-42-T	42	49	26	16-1/2	12	3	6	71
G-42-S	42	35-7/8	17	20	8	3	6	81
G-82	82	62-1/4	33	20	12	3	6	154
G-120	120	63	33	24	12	3	6	206

1-1/4" NPT Spud in head for alternate motor mount or retention tank connection

All tapping 1-1/4" Water Connections

1/4" pressure switch tapping on all models

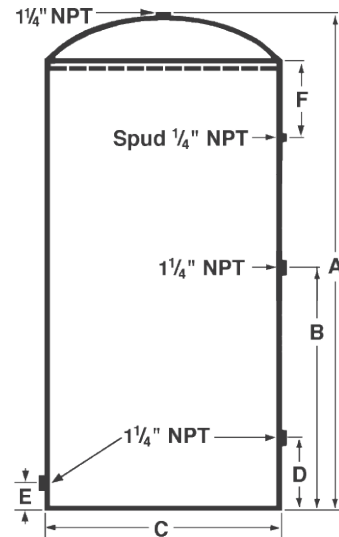

HEAVY-DUTY STATE PROLINE® GALVANIZED



Galvanized Tanks Z Series

1-YEAR LIMITED WARRANTY

- Vertical Tanks
- Maximum working pressure 75 psig
- NSF Certified 61G & 372
- For complete information, consult written warranty or go to statewaterheaters.com.

VERTICAL TANKS Z SERIES 12 TO 120 GALLONS – FREE STANDING

Model Number	Volume (Gallons)	Dimensions in Inches					Weight (lbs)
		A	B	C	D	E	
Z-12	12	26-1/2	24	12	5	13	27
Z-21	21	26-7/8	24	16	5	13	45
Z-32	32	38-3/4	36	16	8	17	52
ZT-42	42	51	48	16	12	26	71
ZS-42	42	33-5/8	30	20	8	17	71
Z-82	82	63	60	20	12	33	114
Z-120	120	64-1/2	60	24	12	33	154

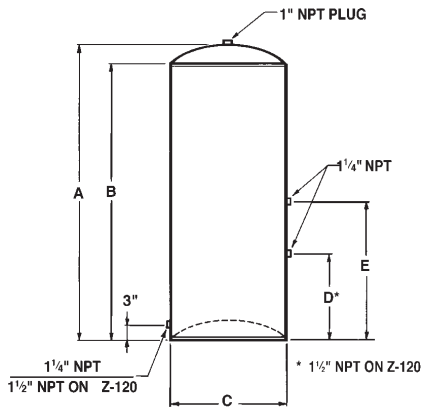

VERTICAL TANKS Z SERIES 220-480 GALLONS

Model Number	Volume (Gallons)	Dimensions in Inches									Weight (lbs)
		A	B	C	D	E	G	J	K	L	
Z-220	220	78	66	30	6	32	6	2-1/2	2	2	303
Z-315	315	79-1/2	66	36	6	32	7	2-1/2	2	2	416
Z-480	480	87	72	42	6	32	7-1/2	2-1/2	2	3	640

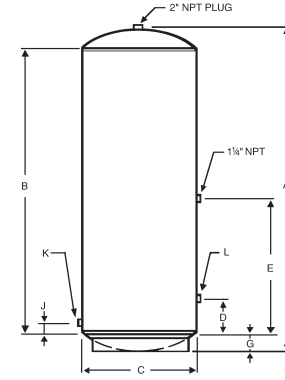

UNIVERSAL TANKS Z SERIES 525-900 GALLONS

Model Number	Volume (Gallons)	Dimensions in Inches								Weight (lbs)
		A	B	C	D	E	F	G	J	
ZU-525	525	131	114	36	6	56	2-1/2	2-1/2	2" NPT	685
ZU-900	900	161	144	42	14	69	4	4	3" NPT	1040

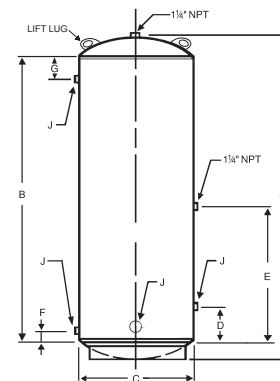



WATERGUARD™

POTABLE WATER HEATER EXPANSION TANKS

- For use with residential and commercial water heaters to a maximum of 180°.
- Field-adjustable 38 psi air charge.
- IAPMO approved (150 psig Models).
- Tanks are NSF Standard 61-G and 372 listed.
- 5-year limited tank warranty.

THERM-O-FLEX™

POTABLE WATER HEATER EXPANSION TANKS

- In-Line Series, Models ETC-7, ETC-14, 3/4" FPT.
- Free Standing Series Models ETC-15 to ETC-36, 1" FPT.
- ETC-52 to ETC-86, 1-1/4" FPT.
- Tanks are NSF Standard 61-G and 372 listed.
- 5-year limited warranty.



For complete information, consult written warranty or go to statewaterheaters.com.

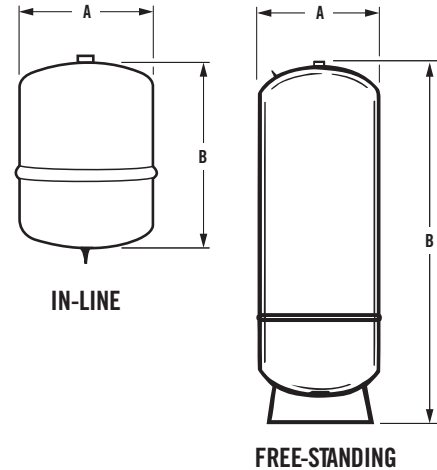

Model Number	Maximum (psig) Working Pressure	Tank Volume (Gallons)	Maximum Accepted Volume (Gallons)			Connection NPT Size	A	B	Weight (lbs)
			20 psi	40 psi	60 psi				
Waterguard™-Series (Potable Expansion Tanks - 5-Year Limited Warranty)									
ETC-10X	150	9.25	7.80	6.55	5.25	3/4	15-1/2	15-3/8	18
Therm-o-Flex™ Series (Potable Expansion Tanks - 5-Year Limited Warranty)									
ETC-7	100	7.27	4.6	N/A	N/A	3/4	21-1/16	11	14
ETC-14	100	14.6	10.5	8.0	5.6	3/4	23-1/2	15-3/8	25
ETC-15	100	14.6	10.5	8.0	5.6	1	24-3/4	15-3/8	25-1/2
ETC-20	100	20	13.5	10.1	6.7	1	32-3/4	15-3/8	30
ETC-36S	100	36	21	16.6	11.4	1	32-3/8	20	45
ETC-52	100	52	33.8	25.5	19.7	1-1/4	38-5/8	23-3/8	77
ETC-86	100	86	61.2	45.4	32.8	1-1/4	59	23-3/8	105



SPACE HEATING EXPANSION TANKS

FOR USE WITH RESIDENTIAL SPACE HEATING BOILERS IN CLOSED SYSTEMS

- Not for use with potable water heating systems.
- Designed for in-line or free standing installation.
- Combination models shipped with air vent and separator.
- Field-adjustable 12 psi air charge.
- Drawn-steel tank with butyl rubber parabolic diaphragm separates air and water.
- Maximum temperature 240° F.
- 100 psi maximum working pressure.
- 1-year tank limited warranty.
- For complete information, consult written warranty or go to statewaterheaters.com.

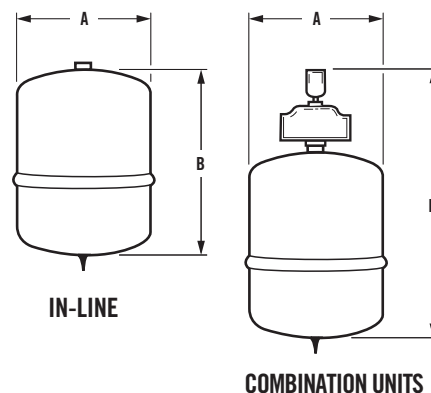

Model Number	Gallon Capacity	Max. Acceptable Volume (Gallons) 20 psig	Dimensions in Inches		Shipping Weight (lbs)
			Height	Diameter	
Therm-o-Flex In-Line					
ET-2	1.86	1.53	10-3/16	8-1/4	5
ET-5	4.83	3.75	14-3/4	11	9
ET-7	7.27	4.6	21-1/16	11	14
ET-14	14.6	10.5	21-3/4	15-3/8	22
Therm-o-Flex Combination Units*					
ET-2V-1	1.86	1.53	20-11/16	8-1/4	10
ET-2V-2	1.86	1.53	20-11/16	8-1/4	10
ET-5V-1	4.83	3.75	25-1/8	11	13
ET-5V-2	4.83	3.75	25-1/8	11	13
ET-7V-1	7.27	4.6	31-3/8	11	16
ET-7V-2	7.27	4.6	31-3/8	11	16

*Combination Units with Air Vent and Air Separator

All Models: 100 psig Maximum Working Pressure

All In-Line Models have 1/2" MPT connections

Combination Units Air Vent Connection Sizes: ET-2V-1, ET-5V-1, ET-7V-1 have 1" female connection

Combination Units Air Vent Connection Sizes: ET-2V-2, ET-5V-2, ET-7V-2 have 1-1/4" female connection

PROLINE® XE CONDENSING WITH RECIRCULATION PUMP



**PROLINE® XE
BEST**



Indoor



Outdoor



ANSI Z21. 10.3 CSA 4.3

INTEGRATED RECIRCULATION PUMP

- 1/2" pipe - 100'
- 3/4" pipe - 500'

PUMP CONTROLS

- Included with heater
- Two timer settings
- Adjustable differential settings

ENERGY STAR® QUALIFIED

ULTRA-LOW NOx EMISSIONS

- Complies with SCAQMD 1146.2 NOx emission requirements of 14 ng/J or 20 PPM

INDOOR MODELS

- Include integrated temperature and pump controls with advanced diagnostics that simplify installation and troubleshooting.
- Factory-installed power cord

OUTDOOR MODELS

- Includes a wall mount temperature remote controller and advanced diagnostics to simplify troubleshooting

COMMON VENT INDOOR MODELS UP TO 8 HEATERS

540P

- Easy-link with up to three 540H condensing tankless heaters to increase flow capacity.

SAFETY FEATURES

- Air-Fuel ratio (AFR) sensor
- Exhaust & water temperature safety control
- Overheat cut-off fuse

INTERNAL FREEZE PROTECTION

WARRANTY

- 15-year limited warranty on heat exchanger in residential applications
- 6-year limited warranty on heat exchanger in commercial applications
- 5-year limited warranty on all parts
- For complete information, consult written warranty or go to statewaterheaters.com.

INDOOR MODEL

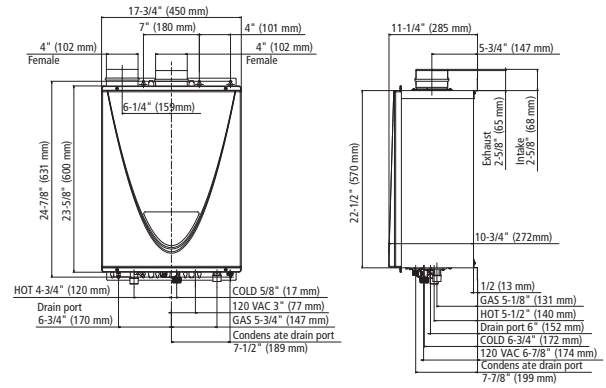

OUTDOOR MODEL

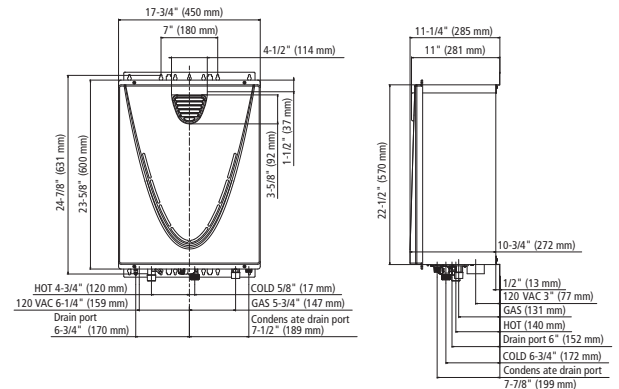

Model Number*	Type	Gas Consumption Input		Inlet Gas Pressure***		Energy Factor (EF)	Approx Shipping Weight (lbs)
		Minimum** (BTU/H)	Maximum (BTU/H)	Minimum (in. W.C.)	Maximum (in. W.C.)		
GTS-540P-NIH	Natural	15,000	199,000	4.0	10.5	0.95	61

Model Number*	Connections		Sizing Chart (Number of Showers)		Clearances (in.)			
	Water	Gas	Cold Climate†	Warm Climate‡	Top	Bottom	Side	Front
GTS-540P-NIH	3/4" NPT	3/4" NPT	3	4.5	12	12	3	4

* For outdoor models, change "NIH" to "NEH". For propane models, change "N" to "P".

** For propane models, minimum is 13,000.

*** For propane models, minimum inlet gas pressure is 8.0 in. W.C. and maximum inlet gas pressure is 14.0 in. W.C.

† Cold climate represents 70°F temperature rise.

‡ Warm climate represents 50°F temperature rise.

PROLINE® XE CONDENSING HIGH EFFICIENCY



**PROLINE® XE
BEST**

ENERGY STAR® QUALIFIED

CONDENSING TECHNOLOGY PROVIDES 0.93 ENERGY FACTOR (EF)

ULTRA-LOW NO_x EMISSIONS

- Complies with SCAQMD 1146.2 NO_x emission requirements of 14 ng/l or 20 PPM.

COPPER PRIMARY HEAT EXCHANGER

- 25x better heat transfer than stainless steel thus stabilizing outgoing water temperature quicker and reducing pressure drop across the heat exchanger.

SECONDARY HEAT EXCHANGER

- Marine-Grade 316L stainless steel to protect against corrosion.

INDOOR MODELS

- Include a built-in temperature controller and advanced diagnostics to simplify troubleshooting.
- Factory-installed power cord included

OUTDOOR MODELS

- Include a wall mount temperature remote controller and advanced diagnostics to simplify troubleshooting.

ELECTRONIC IGNITION—NO PILOT LIGHT

SAFETY FEATURES:

- Air Fuel Ratio (AFR) Sensor.
- Exhaust and water temperature safety control.
- Overheat cut-off fuse.

INTERNAL FREEZE PROTECTION SYSTEM

POWER VENT OR POWER DIRECT VENT DESIGN

WARRANTY

- 15-year limited warranty on heat exchanger in residential applications.
- 6-year limited warranty on heat exchanger in commercial applications.
- 5-year limited warranty on all parts.
- For complete information, consult written warranty or go to statewaterheaters.com.



Indoor



Outdoor



ANSI Z21. 10.3

CSA 4.3

INDOOR MODEL

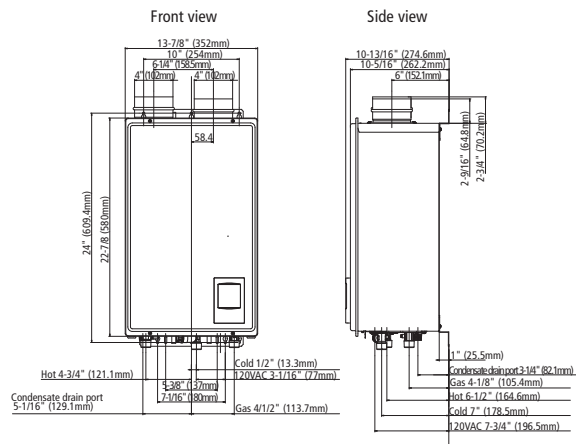

OUTDOOR MODEL

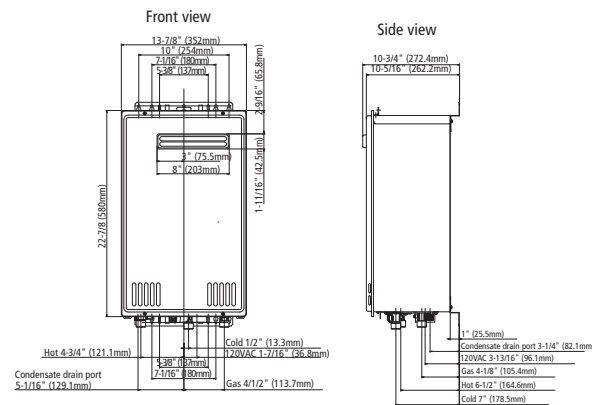

Model Number*	Type	Gas Consumption Input		Inlet Gas Pressure***		Energy Factor (EF)	Connections	
		Minimum** (BTU/H)	Maximum (BTU/H)	Minimum (in. W.C.)	Maximum (in. W.C.)		Water	Gas
GTS-140-NIH	Natural	15,000	120,000	4.0	10.5	0.93	3/4" NPT	1/2" NPT

Model Number*	Sizing Chart (Number of Showers)		Clearances (in.)				Approx Shipping Weight (lbs)
	Cold Climate†	Warm Climate‡	Top	Bottom	Side	Front	
GTS-140-NIH	1.5	2.5	12	12	3	4	52

*For outdoor models, change "NIH" to "NEH". For propane models, change "N" to "P".

**For propane models, minimum is 13,000.

***For propane models, minimum inlet gas pressure is 8.0 in. W.C. and maximum inlet gas pressure is 14.0 in. W.C.

† Cold climate represents 70°F temperature rise.

‡ Warm climate represents 50°F temperature rise.

PROLINE® XE CONDENSING HIGH EFFICIENCY



**PROLINE® XE
BEST**



Indoor



Outdoor



ANSI Z21. 10.3 CSA 4.3

ENERGY STAR® QUALIFIED CONDENSING TECHNOLOGY PROVIDES 0.95 ENERGY FACTOR

ULTRA-LOW NO_x EMISSIONS

- Complies with SCAQMD Rule 1146.2 NO_x emission requirements of 14 ng/J or 20 PPM.

MAXIMUM FLOW RATES UP TO 10.0 GPM HEAT EXCHANGER

- Primary heat exchanger of the GTS-540 is constructed of a commercial-grade copper that is more resilient to erosion. Copper is 25x better at heat transfer than stainless steel thus stabilizing outgoing water temperatures quicker and reducing pressure drop across the heat exchanger.
- Secondary heat exchanger is made of marine-grade 316L stainless steel to protect against corrosion.

INDOOR MODELS

- Include integrated temperature controls and advanced diagnostics to simplify troubleshooting.
- Include factory-installed power cords

OUTDOOR MODELS

- Include wall mount temperature remote controller and advanced diagnostics to simplify troubleshooting.

COMMON VENT INDOOR MODELS UP TO 8 UNITS

540H CAN BE USED IN BOTH RESIDENTIAL AND COMMERCIAL APPLICATIONS

- Easy-link up to 4 heaters.
- Multi-link up to 20 heaters.

SAFETY FEATURES

- Air-fuel Ratio (AFR) Sensor.
- Exhaust and water temperature safety control.
- Overheat cut-off fuse.

INTERNAL FREEZE PROTECTION SYSTEMS

POWER VENT OR POWER DIRECT VENT DESIGN

WARRANTY

- 15-year limited warranty on heat exchanger in residential applications.
- 6-year limited warranty on heat exchanger in commercial applications.
- 5-year limited warranty on all parts.
- For complete information, consult written warranty or go to statewaterheaters.com.

INDOOR MODEL

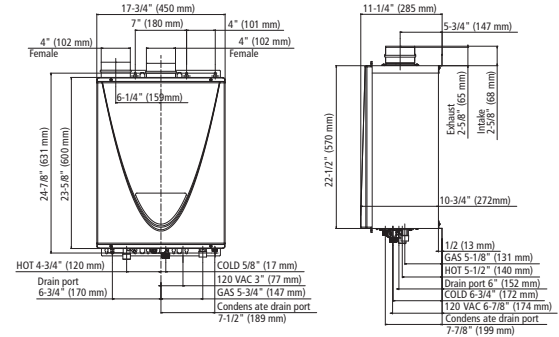

OUTDOOR MODEL

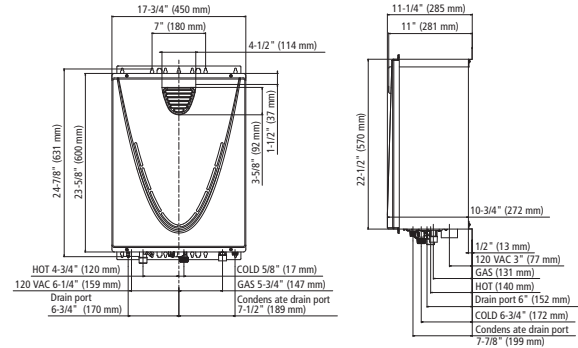

Model Number*	Type	Gas Consumption Input		Inlet Gas Pressure***		Energy Factor (EF)	Connections	
		Minimum** (BTU/H)	Maximum (BTU/H)	Minimum (in. W.C.)	Maximum (in. W.C.)		Water	Gas
GTS-240H-NIH	Natural	15,000	160,000	4.0	10.5	0.95	3/4" NPT	3/4" NPT
GTS-340H-NIH	Natural	15,000	180,000	4.0	10.5	0.95	3/4" NPT	3/4" NPT
GTS-540H-NIH	Natural	15,000	199,000	4.0	10.5	0.95	3/4" NPT	3/4" NPT

Model Number*	Sizing Chart (Number of Showers)		Clearances (in.)				Approx Shipping Weight (lbs)
	Cold Climate†	Warm Climate‡	Top	Bottom	Side	Front	
GTS-240H-NIH	2.5	2.5	12	12	3	4	62
GTS-340H-NIH	2.5	3.5	12	12	3	4	62
GTS-540H-NIH	3	4.5	12	12	3	4	63

*For outdoor models, change "NIH" to "NEH". For propane models, change "N" to "P".

**For propane models, minimum is 13,000.

***For propane models, minimum inlet gas pressure is 8.0 in. W.C. and maximum inlet gas pressure is 14.0 in. W.C.

† Cold climate represents 70°F temperature rise.

‡ Warm climate represents 50°F temperature rise.

PROLINE® XE NON-CONDENSING CONCENTRIC VENT



**PROLINE® XE
BEST**



ANSI Z21.10.3



(510c model only)

CONCENTRIC VENT DESIGN

- Power direct vent.
- Vertical or horizontal venting up to 43'.

FIELD CONVERTIBLE FROM NATURAL GAS TO PROPANE

ULTRA-LOW NO_x EMISSIONS

- Complies with SCAQMD Rule 1146.2 NO_x emission requirements of 14 ng/J or 20 PPM.

MAXIMUM FLOW RATES UP TO 10.0 GPM

PRIMARY HEAT EXCHANGER

- Primary heat exchanger of the GTS-510C is constructed of a commercial-grade copper that is more resilient to erosion. Copper is 25x better at heat transfer than stainless steel thus stabilizing outgoing water temperatures quicker and reducing pressure drop across the heat exchanger.

INDOOR MODELS ONLY

- Include integrated temperature controls and advanced diagnostics to simplify troubleshooting.
- Include factory-installed power cords.

GTS-510C CAN BE USED IN BOTH RESIDENTIAL AND COMMERCIAL APPLICATIONS

- Easy-Link up to 4 units.
- Multi-Link up to 20 units.

SAFETY FEATURES

- Air-Fuel Ratio (AFT) sensor.
- Water temperature safety control.
- Overheat cut-off fuse.

INTERNAL FREEZE PROTECTION

WARRANTY

- 15-year limited warranty on heat exchanger in residential applications.
- 6-year limited warranty on heat exchanger in commercial applications.
- 5-year limited warranty on all parts.
- For complete information, consult written warranty or go to statewaterheaters.com.

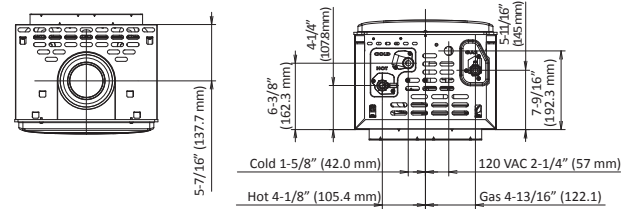

Top view

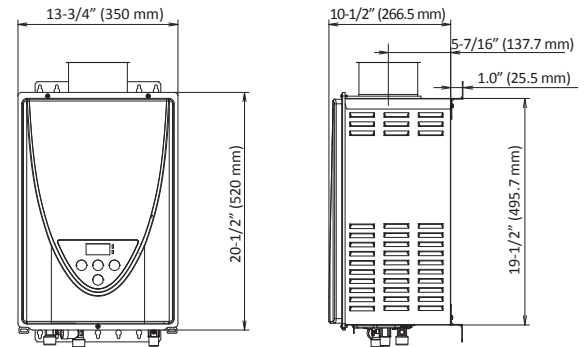

Front view

Side view

Model Number*	Gas Consumption Input		Inlet Gas Pressure**		Energy Factor (EF)	Connections	
	Minimum (BTU/H)	Maximum (BTU/H)	Minimum (in. W.C.)	Maximum (in. W.C.)		Water	Gas
GTS-110C-N	15,000	140,000	4.0	10.5	0.82	3/4" NPT	3/4" NPT
GTS-310C-N	15,000	190,000	4.0	10.5	0.82	3/4" NPT	3/4" NPT
GTS-510C-N	15,000	199,000	4.0	10.5	0.82	3/4" NPT	3/4" NPT

Model Number*	Sizing Chart (Number of Showers)		Clearances (in.)				Approx Shipping Weight (lbs)
	Cold Climate†	Warm Climate‡	Top	Bottom	Side	Front	
GTS-110C-N	1.5	2.5	12	12	3	4	55
GTS-310C-N	2.5	3.5	12	12	3	4	55
GTS-510C-N	2.5	3.5	12	12	3	4	55

*Indoor models only. Units are field convertible from natural gas to propane with supplied conversion kit.
 **For propane models, minimum inlet gas pressure is 8.0 in. W.C. and maximum inlet gas pressure is 14.0 in. W.C.
 † Cold climate represents 70°F temperature rise
 ‡ Warm climate represents 50°F temperature rise

**PROLINE® XE
BEST**



Indoor



Outdoor



(510U model only)



ANSI Z21. 10.3

CSA 4.3

MAXIMUM FLOW RATES UP TO 10.0 GPM COPPER PRIMARY HEAT EXCHANGER

- Primary heat exchanger of the GTS-510 is constructed of a commercial-grade copper that is more resilient to erosion. Copper is 25x better at heat transfer than stainless steel thus stabilizing outgoing water temperatures quicker and reducing pressure drop across the heat exchanger.

INDOOR MODELS

- Includes a wall mount temperature remote controller and advanced diagnostics to simplify troubleshooting
- Includes factory-installed power cord

OUTDOOR MODELS

- Includes a wall mount temperature remote controller and advanced diagnostics to simplify troubleshooting

LOW NOx EMISSION

GTS-510 MODELS CAN BE USED IN BOTH RESIDENTIAL AND COMMERCIAL APPLICATIONS

- Easy-Link up to 4 Units

SAFETY FEATURES

- Air-fuel Ratio (AFR) Sensor.
- Water temperature safety control.
- Overheat cut-off fuse.

INTERNAL FREEZE PROTECTION

POWER VENT OR POWER DIRECT VENT DESIGN

WARRANTY

- 15-year limited warranty on heat exchanger in residential applications.
- 6-year limited warranty on heat exchanger in commercial applications.
- 5-year limited warranty on all parts.
- For complete information, consult written warranty or go to statewaterheaters.com.

INDOOR MODEL (dimensions for 310/510 models)

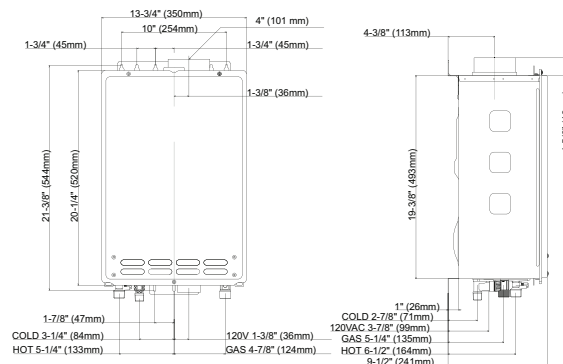

OUTDOOR MODEL (dimensions for 310/510 models)

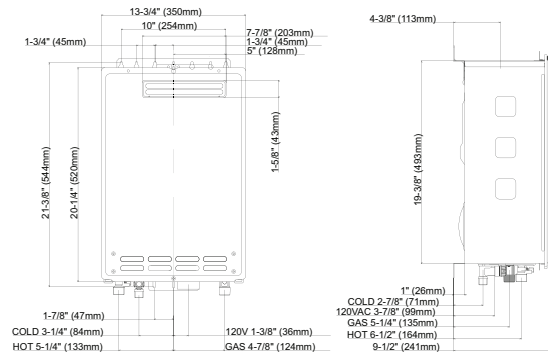

Model Number*	Type	Gas Consumption Input		Inlet Gas Pressure**		Energy Factor (EF)	Connections	
		Minimum (BTU/H)	Maximum (BTU/H)	Minimum (in. W.C.)	Maximum (in. W.C.)		Water	Gas
GTS-110-NI	Natural	19,500	140,000	4.0	10.5	0.82	3/4" NPT	3/4" NPT
GTS-310-NI	Natural	11,000	190,000	4.0	10.5	0.82	3/4" NPT	3/4" NPT
GTS-510-NI	Natural	11,000	199,000	4.0	10.5	0.82	3/4" NPT	3/4" NPT

Model Number*	Sizing Chart (Number of Showers)		Clearances (in.)				Approx Shipping Weight (lbs)
	Cold Climate†	Warm Climate‡	Top	Bottom	Side	Front	
GTS-110-NI	1.5	2.5	12	12	3	4	38
GTS-310-NI	2.5	3.5	12	12	3	4	43
GTS-510-NI	2.5	3.5	12	12	3	4	45

*For outdoor models, change "NI" to "NE". For propane models, change "N" to "P".
For propane models, minimum inlet gas pressure is 13,000.

**For propane models, minimum inlet gas pressure is 8.0 in. W.C. and maximum inlet gas pressure is 14.0 in. W.C.

† Cold climate represents 70°F temperature rise.

‡ Warm climate represents 50°F temperature rise.

TANKLESS NON-CONDENSING ULTRA-LOW NO_x



**PROLINE® XE
BEST**



Indoor



Outdoor



ANSI Z21. 10.3

ULTRA-LOW NO_x EMISSIONS

- Complies with SCAQMD Rule 1146.2 NO_x emission requirements of 14 ng/J or 20 PPM.

FIELD CONVERTIBLE FROM NATURAL GAS TO PROPANE.

MAXIMUM FLOW RATES UP TO 10.0 GPM

COPPER PRIMARY HEAT EXCHANGER

- Primary heat exchanger of the GTS-510U is constructed of a commercial-grade copper that is more resilient to erosion. Copper is 25x better at heat transfer than stainless steel thus stabilizing outgoing water temperatures quicker and reducing pressure drop across the heat exchanger.

INDOOR MODELS

- Include integrated temperature controls and advanced diagnostics to simplify troubleshooting.
- Include factory-installed power cords.

OUTDOOR MODELS

- Include a wall mount temperature remote controller and advanced diagnostics to simplify troubleshooting.

GTS-510U CAN BE USED IN BOTH RESIDENTIAL AND COMMERCIAL APPLICATIONS

- Easy-Link up to 4 units.
- Multi-Link up to 20 units.

SAFETY FEATURES

- Air-Fuel Ratio (AFR) Sensor.
- Exhaust and water temperature safety control.
- Overheat cut-off fuse.

INTERNAL FREEZE PROTECTION

POWER VENT OR POWER DIRECT VENT DESIGN

WARRANTY

- 15-year limited warranty on heat exchanger in residential applications.
- 6-year limited warranty on heat exchanger in commercial applications.
- 5-year limited warranty on all parts.
- For complete information, consult written warranty or go to statewaterheaters.com.

INDOOR MODEL

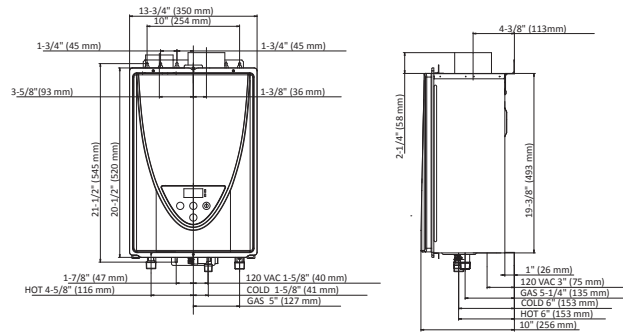

OUTDOOR MODEL

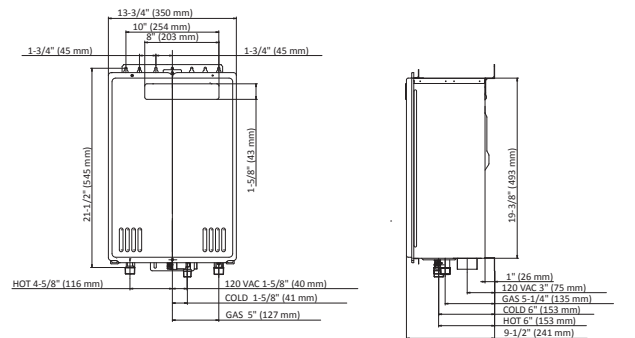

Model Number*	Type	Gas Consumption Input		Inlet Gas Pressure**		Energy Factor (EF)	Connections	
		Minimum (BTU/H)	Maximum (BTU/H)	Minimum (in. W.C.)	Maximum (in. W.C.)		Water	Gas
GTS-110U-I-200	Natural	15,000	140,000	4.0	10.5	0.82	3/4" NPT	3/4" NPT
GTS-310U-I-200	Natural	15,000	190,000	4.0	10.5	0.82	3/4" NPT	3/4" NPT
GTS-510U-I-200	Natural	15,000	199,000	4.0	10.5	0.82	3/4" NPT	3/4" NPT

Model Number*	Sizing Chart (Number of Showers)		Clearances (in.)				Approx Shipping Weight (lbs)
	Cold Climate†	Warm Climate‡	Top	Bottom	Side	Front	
GTS-110U-I-200	1.5	2.5	12	12	3	4	43
GTS-310U-I-200	2.5	3.5	12	12	3	4	43
GTS-510U-I-200	2.5	3.5	12	12	3	4	45

*For outdoor models, change "I" to "E". Units are field convertible from natural gas to propane with supplied conversion kit.

**For propane, minimum inlet gas pressure is 8.0 in. W.C. and maximum inlet gas pressure is 14.0 in. W.C.

† Cold climate represents 70°F temperature rise.

‡ Warm climate represents 50°F temperature rise.

TANKLESS NON-CONDENSING HEAVY-DUTY



COMMERCIAL-GRADE COPPER HEAT EXCHANGER (NON-ASME MODELS)

ASME MODELS AVAILABLE

5" CATEGORY III STAINLESS STEEL VENTING

VERTICAL OR HORIZONTAL VENTING INSTALLATIONS

POWER VENT OR CONVERTIBLE TO POWER DIRECT VENT

ELECTRONIC IGNITION

LOW NO_x EMISSIONS

COMBINED INDOOR/OUTDOOR MODELS

EASY-LINK UP TO 4 UNITS

MULTI-LINK UP TO 10 UNITS

WARRANTY

- 6-year limited warranty on heat exchanger
- 5-year limited warranty on all parts.
- For complete information, consult written warranty or go to statewaterheaters.com.

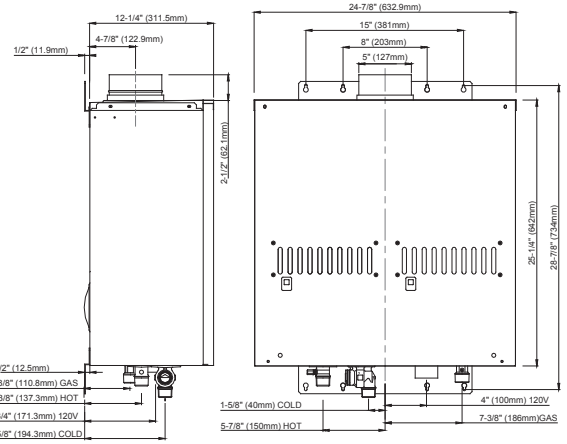

Model Number*	Type	Gas Consumption Input		Inlet Gas Pressure**		Thermal Efficiency	Connections	
		Minimum (BTU/H)	Maximum (BTU/H)	Minimum (in. W.C.)	Maximum (in. W.C.)		Water	Gas
GTS-910-NIE	Natural	15,000	380,000	4.0	10.5	80%	1" NPT	1" NPT
GTS-910-NIEA	Natural	15,000	380,000	4.0	10.5	80%	1" NPT	1" NPT

Model Number*	Sizing Chart (Number of Showers)		Clearances (in.)				Approx Shipping Weight (lbs)
	Cold Climate†	Warm Climate‡	Top	Bottom	Side	Front	
GTS-910-NIE	5	7	12	12	2	24	113
GTS-910-NIEA	5	7	12	12	2	24	113

*"-NIEA" means ASME rated. For propane models, change "N" to "P".

**For propane models, minimum inlet gas pressure is 8.0 in. W.C. and maximum inlet gas pressure is 14.0 in. W.C.

† Cold climate represents 70°F temperature rise.

‡ Warm climate represents 50°F temperature rise.

TANKLESS COMMERCIAL RACK SYSTEM



FREE-STANDING



WALL MOUNT



BACK-TO-BACK

MULTIPLE DESIGN AND INSTALLATION CONFIGURATIONS

- Wall mount, free standing in-line, and free standing back-to-back designs.
- Indoor and outdoor rack designs.
- Uses the 540H high efficiency condensing tankless heaters.

EXPANDABLE

- Up to 1,592,000 BTU on a single rack system.
- Able to link up to 20 heaters together with Multi-Link system.

REDUNDANCY

- Multiple combustion systems provide piece of mind.
- Easily isolate a unit for maintenance which extends the life of the heaters.

LIGHTWEIGHT

- Anodized aluminum frame.
- Utilizes the industry's lightest 199,000 BTU high efficiency condensing tankless heater.

EASY FIELD INSTALLATION

- Reduce installation costs with three simple connections (cold water, hot water, and gas).
- Ultra-Low NOx Emissions.
- Complies with SCAQMD Rule 1146.2 NOx emission requirements of 14 ng/J or 20 PPM.

WARRANTY

- 1-year limited warranty on rack parts.
- For complete information, consult written warranty or go to statewaterheaters.com.

Model Number	Number of Heaters	Btuh Input		Max Flow (GPM)		
		Min	Max	@ 40°F Rise	@ 100°F Rise	@ 140°F Rise
Free-Standing						
ATI-CRS-2IL-N	2	15,000	398,000	18.8	7.6	5.4
ATI-CRS-3IL-N	3	15,000	597,000	28.2	11.4	8.1
ATI-CRS-4IL-N	4	15,000	796,000	37.6	15.2	10.8
Wall Mount						
ATI-CRS-2WM-N	2	15,000	398,000	18.8	7.6	5.4
ATI-CRS-3WM-N	3	15,000	597,000	28.2	11.4	8.1
ATI-CRS-4WM-N	4	15,000	796,000	37.6	15.2	10.8
Back-to-Back						
ATI-CRS-4B2B-N	4	15,000	796,000	37.6	15.2	10.8
ATI-CRS-5B2B-N	5	15,000	995,000	47.0	19.0	13.5
ATI-CRS-6B2B-N	6	15,000	1,194,000	56.4	22.8	16.2
ATI-CRS-7B2B-N	7	15,000	1,393,000	65.8	26.6	18.9
ATI-CRS-8B2B-N	8	15,000	1,592,000	75.2	30.4	21.6

Model Number	Dimensions in Inches			Approx. Shipping Weight (lbs)
	A Height	B Depth	C Width	
Free-Standing				
ATI-CRS-2IL-N	60-1/2	16	46	265
ATI-CRS-3IL-N	60-1/2	16	66	387
ATI-CRS-4IL-N	60-1/2	16	86	580
Wall Mount				
ATI-CRS-2WM-N	58-3/4	13	46	240
ATI-CRS-3WM-N	58-3/4	13	66	350
ATI-CRS-4WM-N	58-3/4	13	86	460
Back-to-Back				
ATI-CRS-4B2B-N	60-1/2	37-3/4	46	580
ATI-CRS-5B2B-N	60-1/2	37-3/4	66	741
ATI-CRS-6B2B-N	60-1/2	37-3/4	66	800
ATI-CRS-7B2B-N	60-1/2	37-3/4	85	961
ATI-CRS-8B2B-N	60-1/2	37-3/4	85	1020

TANKLESS COMMERCIAL RACK SYSTEM

(CONTINUED)



FREE-STANDING

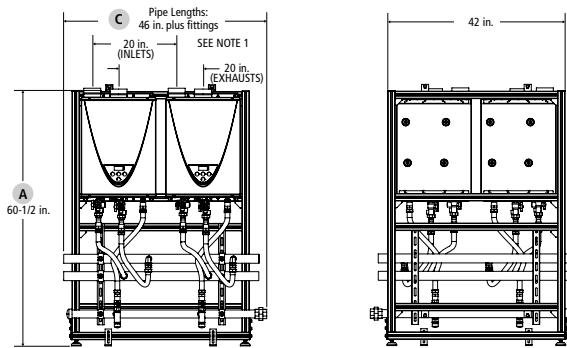

Front

Back

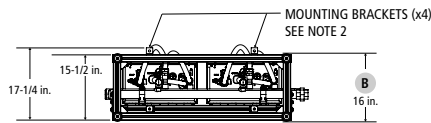

Bottom

- NOTES:
1. TOP-MOUNTED AIR SUPPLY INLET/EXHAUST VENT ARE USED WITH INDOOR MODELS ONLY.
 2. MOUNTING BRACKETS ADJUST HORIZONTALLY ALONG CHANNEL SLOTS.
 3. INDOOR AND OUTDOOR RACK SYSTEMS HAVE IDENTICAL DIMENSIONS. **EXCEPTION:** INDOOR MODELS HAVE TOP-MOUNTED INTAKES AND EXHAUSTS. OUTDOOR MODELS DO NOT.

BACK-TO-BACK

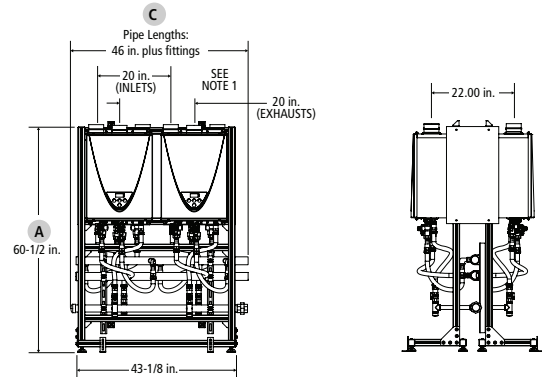

Front

Right

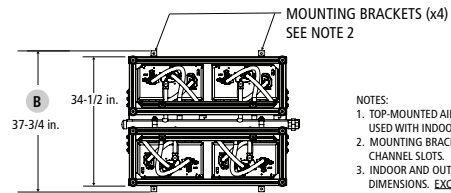

Bottom

- NOTES:
1. TOP-MOUNTED AIR SUPPLY INLET/EXHAUST VENT ARE USED WITH INDOOR MODELS ONLY.
 2. MOUNTING BRACKETS ADJUST HORIZONTALLY ALONG CHANNEL SLOTS.
 3. INDOOR AND OUTDOOR RACK SYSTEMS HAVE IDENTICAL DIMENSIONS. **EXCEPTION:** INDOOR MODELS HAVE TOP-MOUNTED INTAKES AND EXHAUSTS. OUTDOOR MODELS DO NOT.

WALL MOUNT

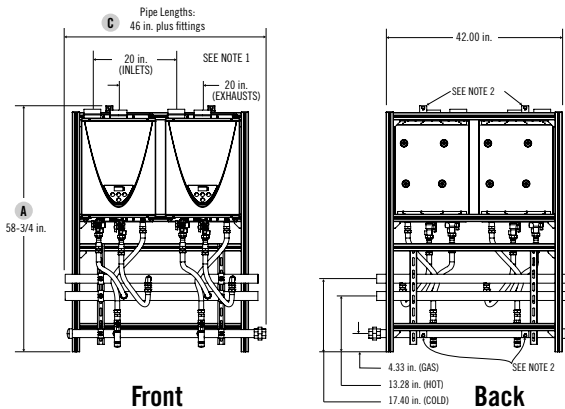

Front

Back

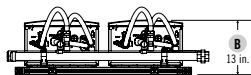

Bottom

- NOTES:
1. TOP-MOUNTED AIR SUPPLY INLET/EXHAUST VENTS ARE USED WITH INDOOR MODELS ONLY.
 2. MOUNTING BRACKETS ADJUST HORIZONTALLY ALONG CHANNEL SLOTS.
 3. INDOOR AND OUTDOOR RACK SYSTEMS HAVE IDENTICAL DIMENSIONS. **EXCEPTION:** INDOOR MODELS HAVE TOP-MOUNTED INTAKES AND EXHAUSTS. OUTDOOR MODELS DO NOT.

BUILDING MANAGEMENT SYSTEM BACnet and MODBUS INTERFACE



- Use the ICC Control to enable/disable the water heater
- Change temperature set points and differentials
- Two models with four different configurations to connect to BACnet and Modbus
- Ethernet and Serial RS-485 versions available
- 2 wire or 4 wire RS-485 Network
- Heater connection wiring supplied with unit
- Power can be supplied via the USB cable, as a 7-24 VDC input on the main terminal block, or via IEEE 802.3af power over ethernet (PoE on ETH-1000 only)
- Configure protocols, network characteristics, and client/server object definitions
- Graphically interact with the internal database in real-time via USB connection
- Automatically discover and configure IP settings ethernet gateways connected to the current subnet
- Update firmware



MODELS:

ETH-1000
Ethernet Connection

XLTR-1000
Serial RS-485 Connection

Protocol	Part #	Connection Type	Application	Net Distributor Price
BACnet	100131364	Serial (RS485)	Commercial Gas – Ultra Force SUF all models and Force 90+ SHE-50/75-100NE	\$625
	100131365		Commercial Electric – CSB-52 thru CSB-120 with immersion thermostat, SSE, SEV and SHE	625
	100131370	Ethernet (IP)	Commercial Gas – Ultra Force SUF all models and Force 90+ SHE 50/75-100NE	825
	100131371		Commercial Electric – CSB-52 thru CSB-120 with immersion thermostat, SSE, SEV and SEH	825
Modbus	100131367	Serial (RS485)	Commercial Gas – Ultra Force SUF all models and Force 90+ SHE50/75-100NE	625
	100131368		Commercial Electric – CSB-52 thru CSB-120 with immersion thermostat, SSE, SEV and SEH	625
	100131373	Ethernet (IP)	Commercial Gas – Ultra Force SUF all models and Force 90+ SHE50/75-100NE	825
	100131374		Commercial Electric – CSB-52 thru CSB-120 with immersion thermostate, SSE, SEV and SHE	825

FORCE® 90 POWER VENT



POWER VENT DESIGN FOR INSTALLATION VERSATILITY

- Helical internal heat exchanger achieves 90% thermal efficiency, which saves money on operating costs compared to a standard 80% efficient gas water heater.
- Combined vertical and horizontal runs terminating through an outside wall, using Schedule 40 PVC or CPVC pipe.
 - 2" pipe allows vent runs up to 25 equivalent feet
 - 3" pipe allows vent runs up to 65 equivalent feet
 - 4" pipe allows vent runs up to 128 equivalent feet

HIGH OUTPUT WITH SMALL FOOTPRINT

- 22" diameter, combined with 90% efficiency, 50-gallon tank and 76,000 BTU input means Force® 90 can be installed in less space than a larger 75-gallon unit, with equal or better performance

SIDE-MOUNTED HOT AND COLD RECIRCULATING TAPS

3-YEAR LIMITED TANK AND 1-YEAR LIMITED PARTS WARRANTY

- For complete information, consult written warranty or go to statewaterheaters.com.

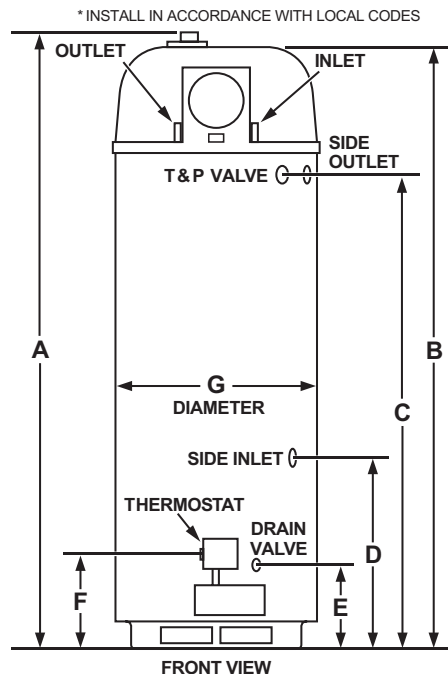
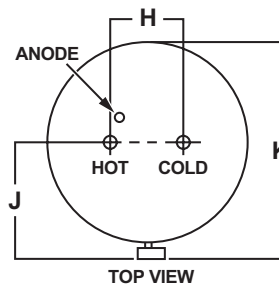

Model Number	Gallon Capacity	Recovery Capacity GPH @ 100°F Rise	BTU Input Per Hour	First Hour Delivery Gallons	Approx. Shipping Weight (lbs)
SHE50 76N	50	92	76,000	127	210

Model Number	Dimensions in Inches									
	A	B	C	D	E	F	G	H	J	K
SHE50 76N	71	68-5/8	52	21	9-1/8	12	22	8	15-3/4	27

Available in natural gas only.
 Standard model certified for sea level to 5,300 ft. elevation. Order SHE70 76NED for elevations to 10,100 ft.
 Optional Condensate Neutralizer Kit available (Part Number 100112380).

FORCE® 90+ POWER DIRECT VENT



CONDENSING DESIGN

- Operates at 96% thermal efficiency, which saves money on operating costs compared to a standard 80% efficient gas water heater.
- Equipped with condensate drain tee.

HELICAL INTERNAL HEAT EXCHANGER

- Spiral heat exchanger keeps hot combustion gases in the tank longer lengthen the heat transfer cycle
- Positioned in the center of the tank for more even heat distribution

POWER DIRECT VENT DESIGN

- Combined vertical and horizontal runs terminating through an outside wall. Vents using PVC, CPVC, ABS, or polypropylene.
- 2" pipe, vents up to 45 equivalent feet
- 3" pipe, vents up to 128 equivalent feet

SIDE-MOUNTED HOT AND COLD RECIRCULATING TAPS

3-YEAR LIMITED TANK AND 1-YEAR LIMITED PARTS WARRANTY

- For complete information, consult written warranty or go to statewaterheaters.com.

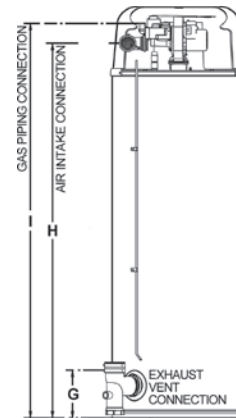
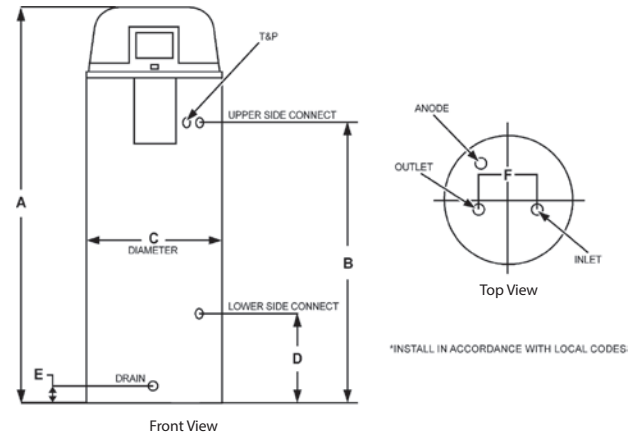

Model Number	Gallon Capacity	Recovery Capacity GPH @ 100°F Rise	BTU Input Per Hour	Approx. Shipping Weight (lbs)
SHE50 100NE	50	129	100,000	255

Model Number	Dimensions in Inches								
	A	B	C	D	E	F	G	H	I
SHE50 100NE	66-3/4	49-1/4	22	15-3/4	3	8	8	62	65

Standard model certified from sea level to 10,100 ft. elevation.
 Optional Concentric Vent Kits (100111100) and Condensate Neutralization Kits (100112380).
 Substitute "P" for "N" in the model number for LP (Propane) gas model.

FORCE® 90+ POWER DIRECT VENT



CONDENSING DESIGN

- Operates at 96% thermal efficiency, which saves money on operating costs compared to a standard 80% efficient gas water heater.
- Equipped with condensate drain tee.

HELICAL INTERNAL HEAT EXCHANGER

- Spiral heat exchanger keeps hot combustion gases in the tank longer lengthen the heat transfer cycle
- Positioned in the center of the tank for more even heat distribution

POWER DIRECT VENT DESIGN

- Combined vertical and horizontal runs terminating through an outside wall. Vents using PVC, CPVC, ABS, or polypropylene.
- 2" pipe, vents up to 45 equivalent feet
- 3" pipe, vents up to 128 equivalent feet

SIDE-MOUNTED HOT AND COLD RECIRCULATING TAPS

3-YEAR LIMITED TANK AND 1-YEAR LIMITED PARTS WARRANTY

- For complete information, consult written warranty or go to statewaterheaters.com

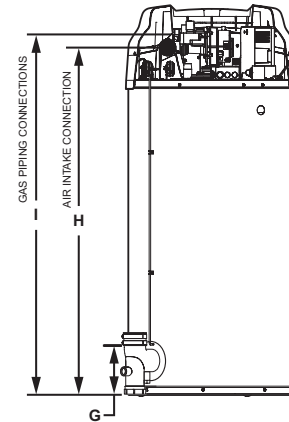
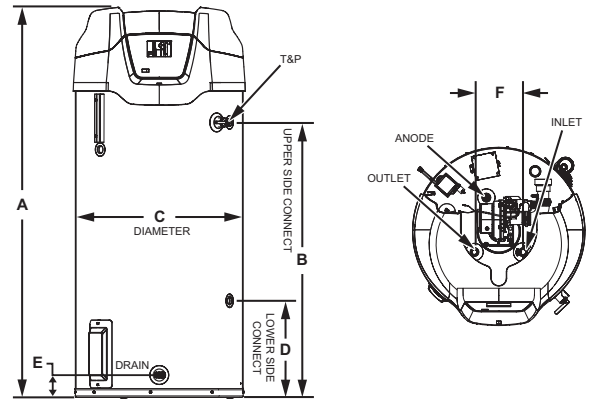

Model Number	Gallon Capacity	Recovery Capacity GPH @ 100°F Rise	BTU Input Per Hour	Approx. Shipping Weight (lbs)
SHE75 100NE	75	129	100,000	382

Model Number	Dimensions in Inches								
	A	B	C	D	E	F	G	H	I
SHE75 100NE	65-1/4	45-5/8	27-3/4	16	3-3/4	8	8	57-1/4	59

Standard model certified from sea level to 10,100 ft. elevation.
 Optional Concentric Vent Kits (100111100) and Condensate Neutralization Kits (100112380).
 Substitute "P" for "N" in the model number for LP (Propane) gas model (example: SHE75 100PE).

MODULATING ULTRA FORCE®



HIGH EFFICIENCY MODULATING PRE-MIX POWERED BURNER

- Down-fired pre-mix burner provides optimum efficiency and quiet operation
- Top-mounted burner position prevents condensation from affecting burner operation

UP TO 98% EFFICIENT

INTELLIGENT CONTROL SYSTEM WITH TOUCH SCREEN DISPLAY

- Exclusive State designed control system
- Provides detailed water heater status information
- Precise temperature control adjustable from 90 to 180
- Built-in diagnostics
- Run history information
- Ultra Force® water heaters include iCOMM remote connectivity. Models 120-250 require optional Wi-Fi communications kit, models 300-500 come standard with Wi-Fi connectivity.

SUBMERGED COMBUSTION CHAMBER, WITH HELICAL HEAT EXCHANGER COIL

- Positioned in center of tank, surrounded by water to virtually eliminate radiant heat loss from chamber
- Direct spark ignition
- Spiral heat exchanger keeps hot burner gases swirling, uses centrifugal force to maximize efficiency of heat transfer to water in tank
- Spiral heat exchanger reduces lime scale from forming on water-side surfaces, which maintains energy efficiency over time

POWERED ANODES STANDARD ON ALL MODELS

- Provides long-lasting tank protection in varying water conditions
- Powered anodes are non-sacrificial
- Automatically adjusts output needed to properly protect the tank

3-YEAR LIMITED TANK AND 1-YEAR LIMITED PARTS WARRANTY

- For complete information, consult written warranty or go to statewaterheaters.com.

Model Number	Approx. Gallon Capacity	Recovery Capacity	Input BTU/Hr	Approx. Shipping Weight Std	Approx. Shipping Weight ASME
SUF60 120NE(A)	60	138	120,000	460	490
SUF100 150NE(A)	100	178	150,000	523	553
SUF100 199NE(A)	100	235	199,900	523	553
SUF100 250NE(A)	100	291	250,000	523	553
SUF119 300NE(A)	119	349	300,000	855	855
SUF119 400NE(A)	119	460	399,900	855	855
SUF119 500NE(A)	119	576	499,900	855	855

Electrical characteristics - 120V - 60Hz A.C., 5.0A

Change "N" to "P" in model number for propane. "A" in model represents ASME construction.

Concentric Vent Kit 100111100 for SUF60-120 through SUF 100-250 Models

Concentric Vent Kit 100113124 for SUF130-300 & SUF130-500 Models.

Dimensions and Line Drawings on the following pages.



MODULATING ULTRA FORCE®

(CONTINUED)

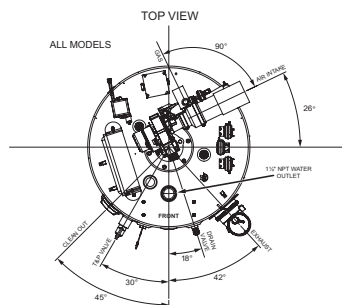

* Center line of water outlet on top of the water heaters is approximately 7 inches from the front edge of the water heater.

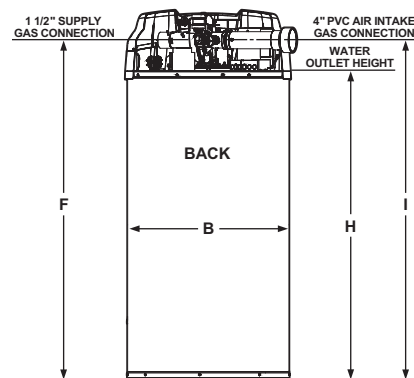
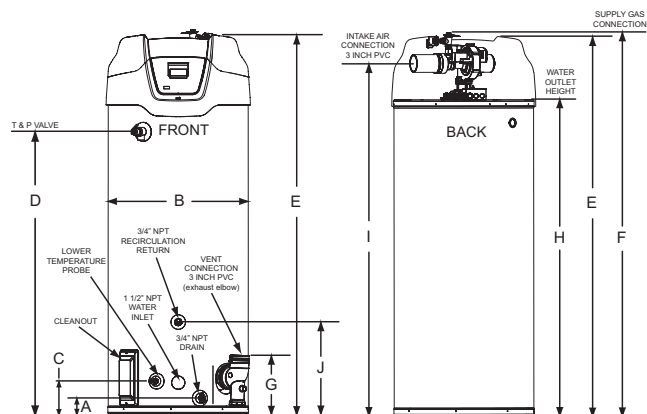
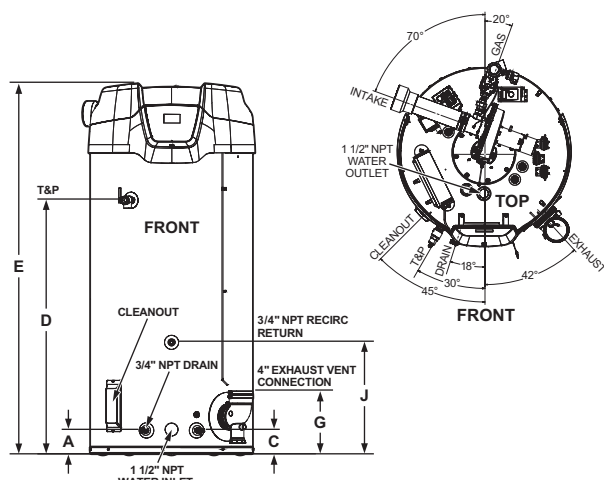

Model Number	Dimensions in Inches									
	A	B	C	D	E	F	G	H	I	J
SUF60 120NE(A)	3	27.75	6.3	35	53.5	55.5	11.25	42.25	48.5	18.25
SUF100 150 NE(A)	3	27.75	6.3	56.38	75.75	76	11.25	64	70	18.25
SUF100 199NE(A)	3	27.75	6.3	56.38	75.75	76	11.25	64	70	18.25
SUF100 250NE(A)	3	27.75	6.3	56.38	75.75	76	11.25	64	70	18.25

Electrical characteristics - 120V - 60Hz A.C., 5.0A

Change "N" to "P" in model number for propane (Example: SUF119 300PE).

"A" in model represents ASME construction.

Concentric Vent Kit 100111100 for SUF60-120 through SUF100-250 Models

Concentric Vent Kit 100113124 for SUF119-300 & SUF119-500 Models.

Models are certified from sea level to 10,100 ft. elevation.

Model Number	Dimensions in Inches									
	A	B	C	D	E	F	G	H	I	J
SUF119 300NE(A)	4.75	33.12	4.75	52	75.75	73.75	12.75	63.13	69.25	23
SUF119 400NE(A)	4.75	33.12	4.75	52	75.75	73.75	12.75	63.13	69.25	23
SUF119 500NE(A)	4.75	33.12	4.75	52	75.75	73.75	12.75	63.13	69.25	23

Electrical characteristics - 120V - 60Hz A.C., 5.0A

Change "N" to "P" in model number for propane (Example: SUF119 300PE).

"A" in model represents ASME construction.

Concentric Vent Kit 100111100 for SUF60-120 through SUF100-250 Models

Concentric Vent Kit 100113124 for SUF119-300 & SUF119-500 Models.

Models are certified from sea level to 10,100 ft. elevation.

POLARIS™ HIGH EFFICIENCY



CONDENSING DESIGN

- Operates at up to 96% thermal efficiency which saves money on operating costs compared to a standard 80% efficient gas water heater.
- Helical internal heat exchanger keeps hot combustion gases in the tank longer to extract more heat into the water.

STAINLESS STEEL CONSTRUCTION

- Tank and helical heat exchanger are constructed from 444 stainless steel for excellent corrosion resistance without the need for an anode.

WHISPER QUIET OPERATION

- Ultra-quiet blower and burner minimize noise.

POWER DIRECT VENT DESIGN

- Direct vent using PVC, CPVC or ABS either thru-the-wall or thru-the-roof.

OPTIONAL CONCENTRIC VENT KIT

ADVANCED ELECTRONIC CONTROL

- Large LCD display provides precise temperature control and advanced diagnostics.

CODE COMPLIANCE

- Complies with SCAQMD Rule 1146.2 and other air quality management districts with similar requirements for Ultra-Low NOx emissions requirements of 14 ng/l or 20 PPM.
- Meets UBC, CEC, and ICC National Codes.
- Meets the thermal efficiency and standby loss requirements of the U. S. Department of Energy and current edition of ASHRAE/ IES 90.1.

3-YEAR LIMITED TANK AND 1-YEAR LIMITED PARTS WARRANTY

- For complete information, consult written warranty or go to statewaterheaters.com.

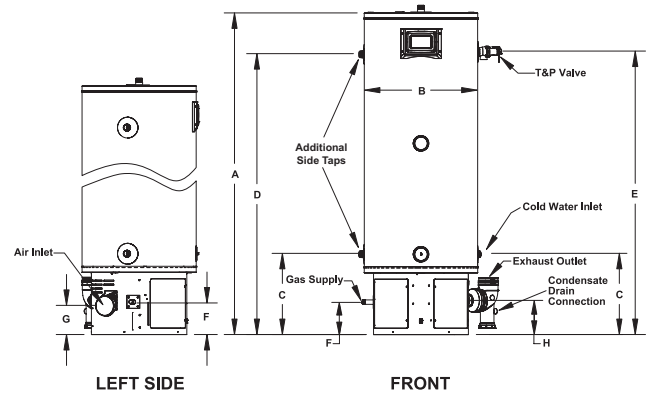
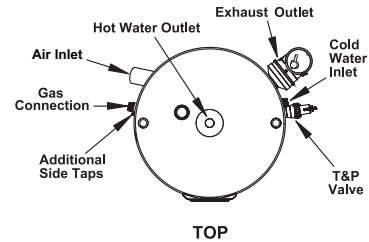

Model Number	Gallon Capacity	BTU/h Input Gallon Per Hour	Thermal Efficiency	Recovery @ 90° Rise Gallon Per Hour	Approx. Shipping Weight (lbs)
SPC 34 130 NE	34	130,000	96%	165	150
SPC 34 150 NE	34	150,000	94%	190	150
SPC 50 130 NE	50	130,000	95%	165	176
SPC 50 150 NE	50	150,000	95%	190	180
SPC 50 175 NE	50	175,000	96%	222	180
SPC 50 199 NE	50	199,000	96%	253	180

Model Number	Dimensions in Inches		Vent Connection	1" Water Connections		T&P	Gas Supply*
	A	B		C	D		
SPC 34 130 NE	48-1/2	22	2 or 3	15-3/4	40-1/2	41	6-3/8
SPC 34 150 NE	48-1/2	22	2 or 3	15-3/4	40-1/2	41	6-3/8
SPC 50 130 NE	62-3/8	22	2 or 3	15-3/4	54-1/2	55	6-3/8
SPC 50 150 NE	63-3/4	22	2 or 3	15-3/4	55-3/4	56-1/4	6-3/8
SPC 50 175 NE	63-3/4	22	3	15-3/4	55-3/4	56-1/4	6-3/8
SPC 50 199 NE	63-3/4	22	3	15-3/4	55-3/4	56-1/4	6-3/8

For Propane (LP) gas change "NE" to "PE"
Models certified for sea level to 7,700 ft. elevation.

SANDBLASTER®

SELF-CLEANING - SBD SERIES



SELF-CLEANING HYDRO CANNON™

- Significantly reduces sediment buildup inside the tank
- Maintains rated thermal efficiency, reduces water heating costs
- Maximizes tank life

AUTOMATIC FLUE DAMPER (120–390 MODELS)

- Automatic motorized flue damper helps minimize standby heat loss
- Low-profile draft diverter helps for installation in tight spaces
- SBD85 500 Model features induced draft design and no damper

THREE WATER CONNECTION OPTIONS

- Hot and cold water connections can be made through front, top or rear of unit
- Hydro Cannon™ operates when cold water is connected through front

INTERMITTENT ELECTRONIC IGNITION

- Eliminates standing pilot, saves energy
- Includes power ON/OFF switch
- Provides flame failure response in less than one second

3-YEAR LIMITED AND 1-YEAR LIMITED TANK WARRANTY

- For complete warranty information, consult written warranty or go to statewaterheaters.com



Model Number	Gallon Capacity	Input BTU/HR	100°F Rise Recovery G.P.H.	Approx. Shipping Weight (lbs)
FLUE DAMPER MODELS				
SBD71 120NE†	71	120,000	116	400
SBD81 154NE	81	154,000	149	470
SBD81 180NE	81	180,000	175	470
SBD100 199NET	100	199,000	193	603
SBD100 199NE	100	199,000	193	603
SBD81 199NE	81	199,000	193	470
SBD100 199NES	100	199,000	193	630
SBD100 250NE*	100	250,000	242	630
SBD65 251NE*	65	251,000	243	750
SBD100 275NE*	100	275,000	267	630
SBD65 305NE	65	305,000	296	750
SBD85 365NE	85	365,000	354	725
SBD100 390NE	100	390,000	378	760
SBD85 500NE***	85	500,000	485	812
ASME MODELS - ASME Models are design certified for a maximum allowable working pressure of 160 psi				
SBD100 199NE A	100	199,000	193	724
SBD100 250NE A*	100	250,000	242	725
SBD65 251NE A*	65	251,000	243	862
SBD100 275NE A*	100	275,000	267	725
SBD65 305NE A	65	305,000	296	862
SBD85 365NE A	85	365,000	354	833
SBD100 390NE A	100	390,000	378	874
SBD85 500NE A***	85	500,000	485	857

Model SBD71 120NE is shipped with 6" x 5" flue outlet adapter.

**Models certified for either 6" or 8" venting, see local codes.

***Induced draft design, Category I Venting

Substitute "P" for "N" in model number for LP (Propane) gas models (Example: SBD100 199PE).

Dimensions and Line Drawings on the following pages.

SANDBLASTER®

SELF-CLEANING - SBD SERIES (CONTINUED)

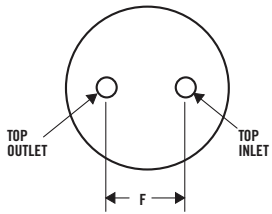

Models SBD 120-390

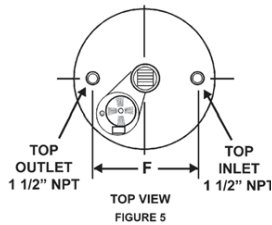
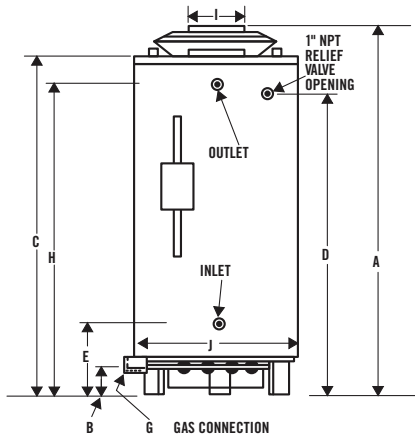

Model SBD 500

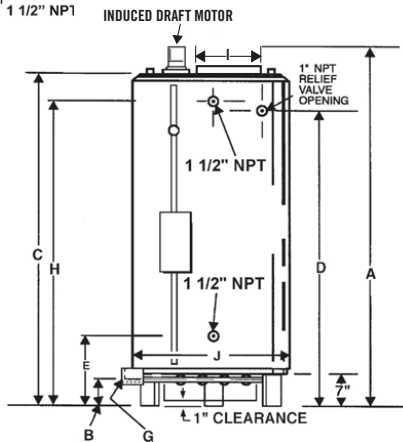

Model Number	Dimensions in Inches					
	A	B	C	D	E	F
SBD71 120NE†	69-3/4	4-1/4	59-1/2	50-7/8	19-11/16	19
SBD81 154NE	73	4-1/4	66-1/2	57-7/8	19-11/16	19
SBD81 180NE	67-1/2	4-1/2	62	53-1/2	20-1/2	21
SBD81 199NE	67-1/2	4-1/2	62	53-5/8	20-1/2	21
SBD100 199NET	75	4-1/2	70	61-5/8	20-1/2	21
SBD100 199NE	75	4-1/2	70	61-5/8	20-1/2	21
SBD100 199NES (A)	67-1/2	4-1/2	62	53-5/8	20-1/2	21
SBD100 250NE (A)*	72	4-1/2	65-1/8	55-7/8	19-3/4	23
SBD65 251NE (A)*	72	4-1/2	65-1/8	55-7/8	19-3/4	23
SBD100 275NE (A)*	72	4-1/2	65-1/8	55-7/8	19-3/4	23
SBD65 305NE (A)	75	4-1/2	65-3/4	57-1/4	20	N/A
SBD85 365NE (A)	79-1/2	4-1/2	70-1/4	62-1/2	22-1/2	23
SBD100 390NE (A)	75-1/2	4-1/2	67-1/2	58-1/4	26-3/4	23
SBD85 500NE (A)***	81-1/2	17-1/2	77-1/4	67-1/2	27	21

Model Number	Dimensions in Inches			
	G	H	I	J
SBD71 120NE†	1/2	51-7/8	6	27-3/4
SBD81 154NE	1/2	59	6	27-3/4
SBD81 180NE	1/2	54-5/8	6	27-3/4
SBD81 199NE	1/2	54-5/8	6	27-3/4
SBD100 199NET	1/2	62-5/8	6	27-3/4
SBD100 199NE	1/2	61-1/2	6	27-3/4
SBD100 199NES (A)	1/2	54-5/8	6	27-3/4
SBD100 250NE (A)*	1/2	56-3/8	8	30-1/4
SBD65 251NE (A)*	1/2	56-3/8	8	30-1/4
SBD100 275NE (A)*	1/2	56-3/8	8	30-1/4
SBD65 305NE (A)	1/2	58-3/4	8	27-3/4
SBD85 365NE (A)	3/4	63	8	27-3/4
SBD100 390NE (A)	3/4	59	8	30-1/4
SBD85 500NE (A)***	1	67-1/2	8	27-3/4

†Model SBD71 120NE is shipped with 6" x 5" flue outlet adapter.

**Models certified for either 6" or 8" venting, see local codes.

***Induced draft design, Category I Venting

Substitute "P" for "N" in model number for LP (Propane) gas models(Example: SBD71 120PE).

SANDBLASTER® BOOSTER MODELS

SELF-CLEANING COMMERCIAL GAS WATER HEATER



STATE HYDRO CANNON™ SELF-CLEANING DEVICE

- Significantly reduces buildup of lime, sand and other sediment in the tank
- Helps water heaters retain their rated efficiency longer and reduce water heating costs

INDUCED-DRAFT DESIGN

- Built-in blower produces power-induced draft of makeup air prior to burner ignition, for more efficient control of heat through the flue collector
- Eliminates performance problems caused by negative indoor air pressure
- Requires no draft hood or barometric damper

RATED AS CATEGORY 1 APPLIANCE

- Can be commonly vented with other Category 1 appliances, using standard metal type "B" vent

3-YEAR LIMITED WARRANTY

- For complete warranty information go to statewaterheaters.com

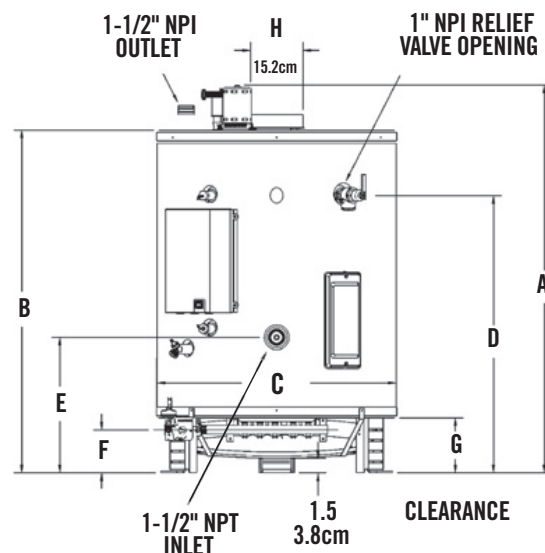

Model Number	Gallon Capacity	Input BTU/HR	Recovery Capacity GPH @ 100°F Rise	Approx. Shipping Weight (lbs) STD/ASME
BOOSTER MODELS - INDUCED DRAFT				
SBD30 150NE (A)	32	150,000	145	440/460
SBD30 199NE (A)	32	199,900	194	440/460

Model Number	Dimensions in Inches							
	A	B	C	D	E	F	G	H
BOOSTER MODELS - INDUCED DRAFT								
SBD30 150NE (A)	45	40	27-3/4	32-1/4	15-3/4	5	6-1/2	6
SBD30 199NE (A)	45	40	27-3/4	32-1/4	15-3/4	5	6-1/2	6

An 6" x 8" vent reducer provided with each unit. Certified for either 6" or 8" venting. See local codes. Substitute "P" for "N" in model number for LP (Propane) gas models (Example: SBD30 150PE).



80% THERMAL EFFICIENCY MEANS LOWER OPERATING COSTS

FAN ASSISTED COMBUSTION

- The blower is built into the low NOx burner assembly
- Complies with California SCAQMD Rule 1146.2 and other Air Quality Management Districts with similar NOx emission requirements of 14 ng/J or 20 ppm

AIR-FLAPPER

- A stainless steel air flapper is used inside the premix system to replace externally mounted flue damper to minimize the standby heat loss and to minimize the overall heater height

METAL VENTING

- Rated Category I Appliance. Uses standard double wall type “B” vent.
- Can be commonly vented with other Category I appliances
- Vent connects directly to the vent connector outlet
- An excellent choice for retrofit and upgrade installations

3-YEAR LIMITED TANK AND 1-YEAR LIMITED PARTS WARRANTY

- For complete warranty information, consult written warranty or go to statewaterheaters.com.



Model Number	Gallon Capacity	Input BTU/HR	Recovery Capacity GPH @ 100°F Rise
SBL81 120NE	81	120,000	115
SBL81 154NE	81	154,000	148
SBL81 180NE	81	180,000	173
SBL81 199NE	81	199,000	191
SBL100 199NE	100	199,000	191
SBL100 250NE	100	250,000	240
SBL100 275NE	100	275,000	264
SBL86 310NE	86	310,000	298
SBL86 366NE	86	366,000	352
SBL86 390NE	86	390,000	375
SBL100 250NEA	100	250,000	240
SBL100 275NEA	100	275,000	264
SBL86 310NEA	86	310,000	298
SBL86 366NEA	86	366,000	352
SBL86 390NEA	86	390,000	375

Electrical characteristics-120V-60 Hz A. C., 5.0A.

“A” after the model number designates ASME construction.

Leg kits for UL sanitation to meet NSF-5 (increase overall height by 4”).

SBL models not available in LP gas.

Dimensions and line drawings on the following pages.

SANDBLASTER® ULTRA-LOW NO_x

(CONTINUED)

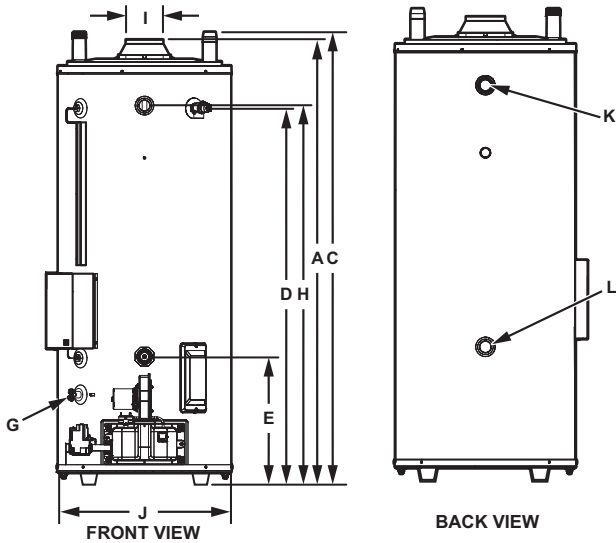
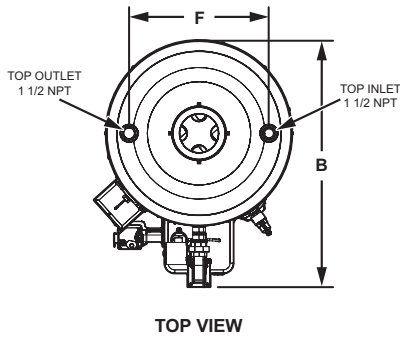

Model Dimension	SBL81 120, 154, 180, 198	SBL100 199, 250(A), 275(A)	SBL86 310(A), 366(A), 400(A)
	Dimensions in Inches		
A	63-3/4	71-3/4	71-3/4
B	37	37	37
C	65	73	73
D	52-3/4	60-3/4	60-3/4
E	20-3/4	20-1/2	20-1/2
F	21	21	21
G	3/4 NPT		
H	53	61	61
I	6	6-8	6-8
J	27-3/4	27-3/4	27-3/4
K	1-1/2 NPT		
L	1-1/2 NPT		
Approx. Shipping Weight (lbs)	SBL81 120, 154, 180, 198	SBL100 199, 250(A), 275(A)	SBL86 310(A), 366(A), 400(A)
Standard	650	750	810
ASME	N/A	800	860

Electrical characteristics-120V-60 Hz A. C., 5.0A.

"A" after the model number designates ASME construction.

Leg kits for UL sanitation to meet NSF-5 (increase overall height by 4").

SBL models not available in LP gas.



CODE COMPLIANCE

- Commercial gas water heater meets the thermal efficiency and standby loss requirements of the U.S. Department of Energy and Current Edition ASHRAE/IES 90.1.

FULLY AUTOMATIC CONTROLS WITH SAFETY SHUTOFF

- Accurate, dependable control system requires no electric connections. Fixed automatic gas shutoff device for added safety. Not recommended for 180°F sanitizing.

HEAVY GAUGE STEEL JACKET

- Finished with baked enamel over bonderized undercoat

FOAM INSULATION

- Saves fuel, helps reduce standby heat loss.

LOW NO_x EMISSIONS

- Complies with Texas and other districts requirements for NO_x emissions less than ng/l.

EASY-TO-INSTALL

- Completely factory-assembled. Only gas, water and vent connections need to be made. All connections are located in front and top of heaters for ease-of-installation and service.

3-YEAR LIMITED TANK AND 1-YEAR LIMITED PARTS WARRANTY

- For complete warranty information, consult written warranty or go to statewaterheaters.com



GAS-FIRED

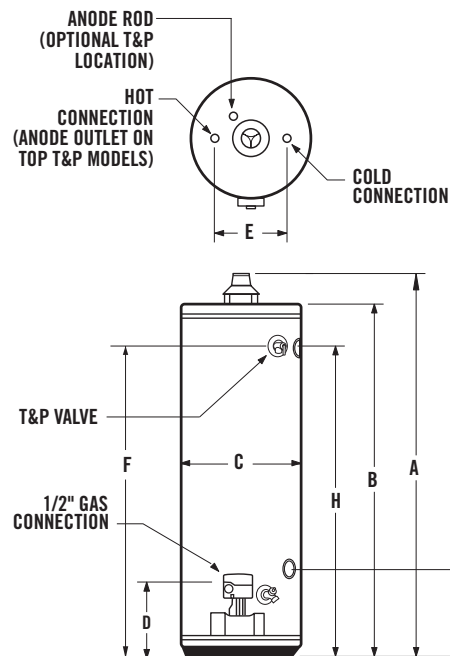

Maximum Hydrostatic Working Pressure: 150 PSI

Gas Type	Capacity		Input Rating		Temperature Rise GPH (LPH)					
	Gallon	Litres	BTU/HR	kW/Hr.	30°F (17°C)	40°F (22°C)	50°F (28°C)	60°F (33°C)	70°F (39°C)	80°F (45°C)
Natural Gas	55	208	60,000	17.6	194 (734)	145 (551)	116 (440)	97 (367)	83 (315)	73 (275)
Propane (LP)	55	208	54,000	15.8	175 (661)	131 (496)	105 (396)	87 (330)	75 (283)	65 (248)

Gas Type	Capacity		Input Rating		Temperature Rise GPH (LPH)					
	Gallon	Litres	BTU/HR	kW/Hr.	90°F (50°C)	100°F (56°C)	110°F (61°C)	120°F (67°C)	130°F (72°C)	140°F (78°C)
Natural Gas	55	208	60,000	17.6	65 (245)	58 (220)	53 (200)	48 (184)	45 (169)	42 (157)
Propane (LP)	55	208	54,000	15.8	58 (220)	52 (198)	48 (180)	44 (165)	40 (152)	37 (142)

Model Number	Gallon Capacity	First Hour Rating Gallon	Energy Factor	Recovery Eff.	BTU Input Natural Gas	BTU Input Propane Gas	GPH Recovery @ 100°F Rise Natural
SBS55 60	55	106	0.59	0.80	60,000	54,000	58

Model Number	GPH Recovery @ 100°F Rise LP	Dimensions in Inches						Approx. Shipping Weight (lbs)	
		A	B	C	D	E	F		
SBS55 60	52	59-3/4	55-1/4	24	13-1/2	8	48	4	185

SANDBLASTER® LIGHT-DUTY



GLASSLINED TANK

- Maximizes tank life.
- Fully Automatic Controls with Safety Shutoff
- Accurate, dependable control system requires no electric connections. Fixed automatic gas shutoff device for added safety. Not recommended for 180°F sanitizing.

HEAVY GAUGE STEEL JACKET

- Finished with baked enamel over bonderized undercoat.

FOAM INSULATION

- Saves fuel, helps reduce standby heat loss.

LOW NO_x

- Complies with Texas and other Districts Requirements for NO_x Emissions Less than 40 ng/l

EASY-TO-INSTALL

- Completely factory-assembled. Only gas, water and vent connections need be made. All connections are located in front and top of heaters for ease of installation and service.

3-YEAR LIMITED TANK/1-YEAR LIMITED PARTS WARRANTY

- For complete warranty information, consult written warranty or go to statewaterheaters.com.

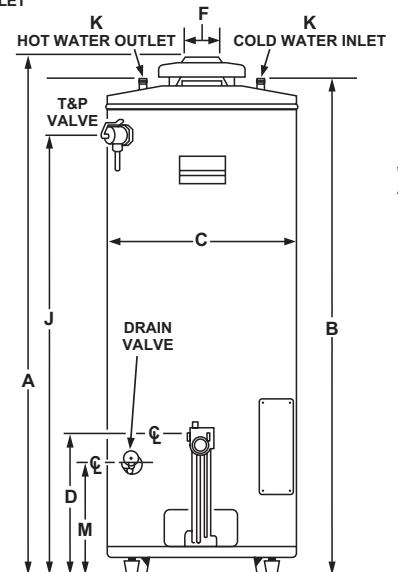
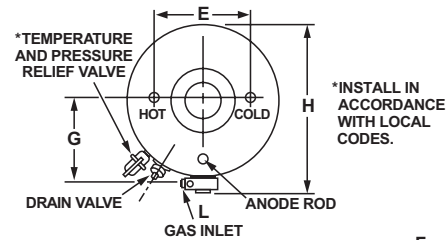

Model Number	Gallon Capacity	Input BTU/HR	Recovery Capacity GPH @ 100°F Rise	Approx. Shipping Weight (lbs)
LIGHT DUTY				
SBS75 76NE	74	75,100	73	275
SBS100 76NE	98	75,100	73	350

Model Number	Dimensions in Inches					
	A	B	C	D	E	F
SBS75 76NE	61-1/8	58-1/2	26-1/2	15-3/16	16	4
SBS100 76NE	68-5/8	66-1/2	27-3/4	15-3/16	16	4

Model Number	Dimensions in Inches					
	G	H	J	K	L	M
SBS75 76NE	14-1/2	29-11/16	54-1/4	1	1/2	11-15/16
SBS100 76NE	15-3/4	30-15/16	54-1/4	1	1/2	11-15/16

NSF leg kit 100111360.
Specify when ordering (LP) gas.

FORCE® POWER DIRECT VENT



SELF-CLEANING DIP TUBE

- Helps reduce lime and sediment buildup and maximizes hot water output. Made from long-lasting PEX cross-linked polymer

BLUE DIAMOND® GLASS COATING

- Provides superior corrosion resistance compared to the industry-standard glasslining.

HOT SURFACE IGNITION

- Has a solid state hot surface ignition that does not flutter or blow out
- Eliminates the pilot and saves energy.

STANDARDS

- Design-certified by CSA International, according to ANSI Z21.10.3-CSA 4.3 standards governing storage-type water heaters.
- Meets the thermal efficiency and standby loss requirements of the U.S. Department of Energy and current edition of ASHRAE/IES 90.1.

3-YEAR LIMITED TANK AND 1-YEAR LIMITED PARTS WARRANTY

- For complete warranty information, consult written warranty or go to statewaterheaters.com

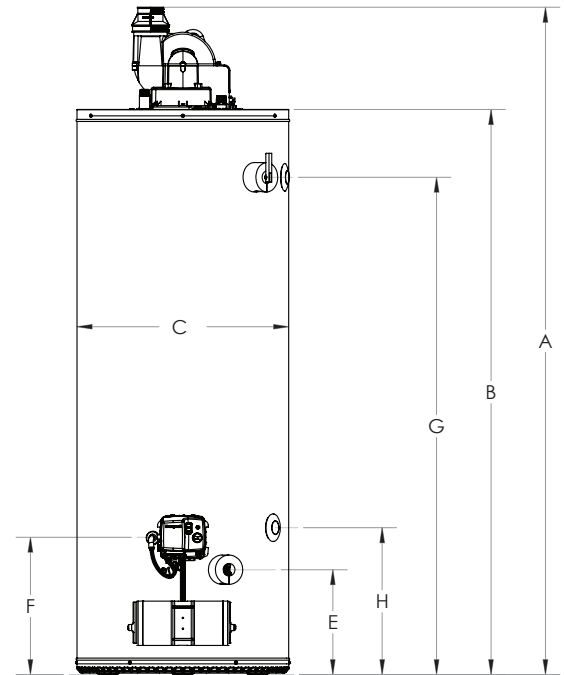
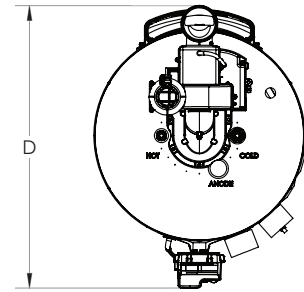

Model Number	Btuh Input	Approx. Capacity	Approx. Shipping Weight (lbs)
SDV75 76NE	76,000	75	277

Model Number	Dimensions in Inches							
	A	B	C	D	E	F	G	H
SDV75 76NE	70-5/8	61-1/4	26	33-1/8	11	13-1/4	53	15-1/4

Can be installed up to 10,100 feet without alteration.
Specify when ordering propane (LP) gas.
Recovery capacity based on 81% thermal efficiency.



CODE COMPLIANCE

- The Ultra-Low NOx atmospheric vent commercial gas water heater which meets the thermal efficiency and standby loss requirements of the U.S. Department of Energy and Current Edition ASHRAE/IES 90.1.

FULLY AUTOMATIC CONTROLS WITH SAFETY SHUTOFF

- Accurate, dependable control system requires no electric connections. Fixed automatic gas shutoff device for added safety. Not recommended for 180°F sanitizing.

HEAVY GAUGE STEEL JACKET

- Finished with baked enamel over bonderized undercoat

FOAM INSULATION

- Saves fuel, helps reduce standby heat loss.

ULTRA-LOW NOx EMISSIONS

- Complies with SCAQMD Rule 1146.2 and other Air Quality Management Districts with similar requirements of 14 ng/J or 20 ppm.

EASY-TO-INSTALL

- Completely factory-assembled. Only gas, water and vent connections need to be made. All connections are located in front and top of heaters for ease-of-installation and service.

3-YEAR LIMITED TANK AND 1-YEAR LIMITED PARTS WARRANTY

- For complete warranty information, consult written warranty or go to staterwaterheaters.com

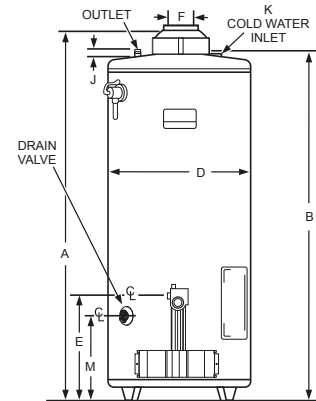
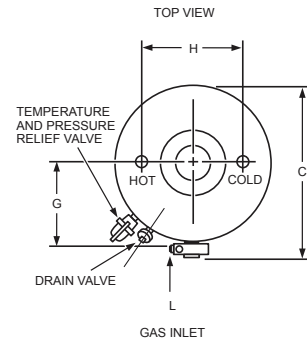

Model Number	Gallon Capacity	Input BTU/HR	Recovery Capacity GPH @ 100° Rise	Approx. Shipping Weight (lbs)
SBL75 76NE**	74	75,100 BTU/h	73	285
SBL100 76NE*	98	75,100 BTU/h	74	350

Model Number	Dimensions in Inches					
	A	B	C	D	E	F
SBL75 76NE	62-1/16	58	29-1/2	25-1/4	15-7/8	4
SBL100 76NE	70-1/2	66-1/2	30-15/16	27-3/4	15-3/16	4

Model Number	Dimensions in Inches					
	G	H	J	K	L	M
SBL75 76NE	15-1/4	16	2	1	1/2	12-1/2
SBL100 76NE	15-3/4	16	1-1/4	1-1/4	1/2	11-15/16

Available in natural gas only.

*Recovery rating based on 81% thermal efficiency

**Recovery rating based on 80% thermal efficiency

STATE TITAN® POWER GAS BURNER



POWERED GAS BURNER

- Premix burner operation
- Safety features: Internal blocked flue sensor, separate pilot system, internal thermal cutoff and anti-flashback barrier

CATEGORY 1 VENTING

- Conventional atmospheric venting on GPG models only with supplied Barometric Draft damper.

AUTOMATIC CONTROLS

- Safety shut-off, high-temperature limit control
- Dual thermostat for accurate temperature adjustment from 120°F to 180°F

3-YEAR LIMITED TANK AND 1-YEAR LIMITED PARTS WARRANTY

- For complete warranty information, consult written warranty or go to statewaterheaters.com



Model Number	BTU Input Per Hour	Tank Size	GPH	Recovery Gallons Per Hour Temperature Rise	Maximum Amperes 120V, 60 Hz, 1
				100°	
GP681 140NE (A)	140,000	81	GPH	136	5
GP681 199NE (A)	199,000	81	GPH	193	5
GP681 270NE (A)	270,000	81	GPH	262	5
GP681 370NE (A)**	370,000	81	GPH	359	5

** GP681 370NE available in Natural Gas only.

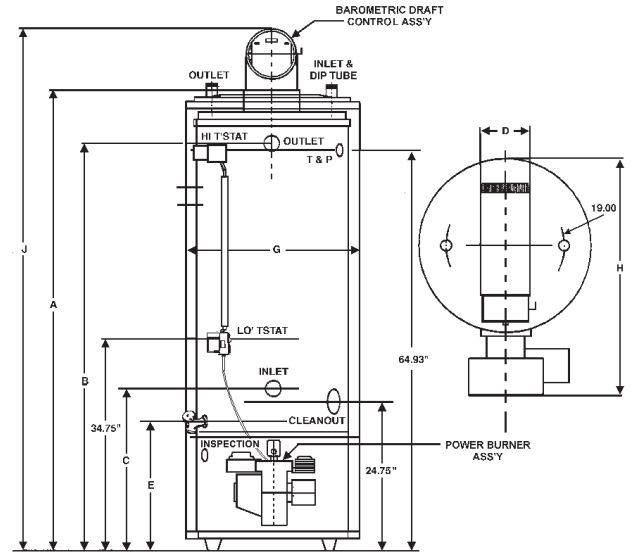

Model Number	Dimensions in Inches				
	A	B	C	D	E
GP681 140NE (A)	74-3/4	65	26-3/4	6	21-3/8
GP681 199NE (A)	74-3/4	65	26-3/4	6	21-3/8
GP681 270NE (A)	74-3/4	65	26-3/4	6	21-3/8
GP681 370NE (A)**	74-3/4	65	26-3/4	6	21-3/8

Model Number	Dimensions in Inches			Approx. Shipping Weight	
	G	H	J	Standard	ASME
GP681 140NE (A)	27-3/4	38	85-1/4	556 lbs	658 lbs
GP681 199NE (A)	27-3/4	38	85-1/4	545 lbs	635 lbs
GP681 270NE (A)	27-3/4	38	85-1/4	547 lbs	632 lbs
GP681 370NE (A)**	27-3/4	38	85-1/4	547 lbs	632 lbs

** GP681 370NE available in Natural Gas only.

Specify when ordering propane (LP) gas.

"A" in the model number represents ASME construction.

Change "N" to "P" in the model number for Propane.

Burner and barometric control packaged separately.

STATE TITAN® LOW NOx POWER GAS BURNER



POWERED GAS LOW NOx BURNER (NATURAL GAS ONLY)

- Premix burner operation includes internal Flue Gas Recirculation (FGR)
- Safety features: Internal blocked flue sensor, separate pilot system, internal thermal cutoff and anti-flashback barrier

THREE VENTING OPTIONS

- Conventional atmospheric venting on GPG models only with supplied Barometric Draft damper.
- Horizontal atmospheric sidewall venting or direct venting on GPV models only
- For sidewall venting order Vent Kit Part # 100125500
- For direct venting order Vent Kit Part # 100131270

AUTOMATIC CONTROLS

- Safety shut-off, high-temperature limit control
- Dual thermostat for accurate temperature adjustment from 120°F to 180°F

3-YEAR LIMITED TANK AND 1-YEAR LIMITED PARTS WARRANTY

- For complete warranty information, consult written warranty or go to statewaterheaters.com



Model Number	Gallon Capacity GPH @ 100°F Rise	Input/BTU/HR Natural Gas	Recovery Capacity	Approx. Shipping Weight (lbs)
GP685 540NEA	85	540,000	523	950
GP685 650NEA	85	650,000	630	950
GP685 740NEA	85	740,000	718	950

Not available in propane (LP).

Vent Kit included in unit price when ordered with heater.

Authorized start-up service included; required to activate warranty. (Continental U.S. only).

For direct or sidewall vent change the last letter in the model to "V" (example: GPV85 540NEA).

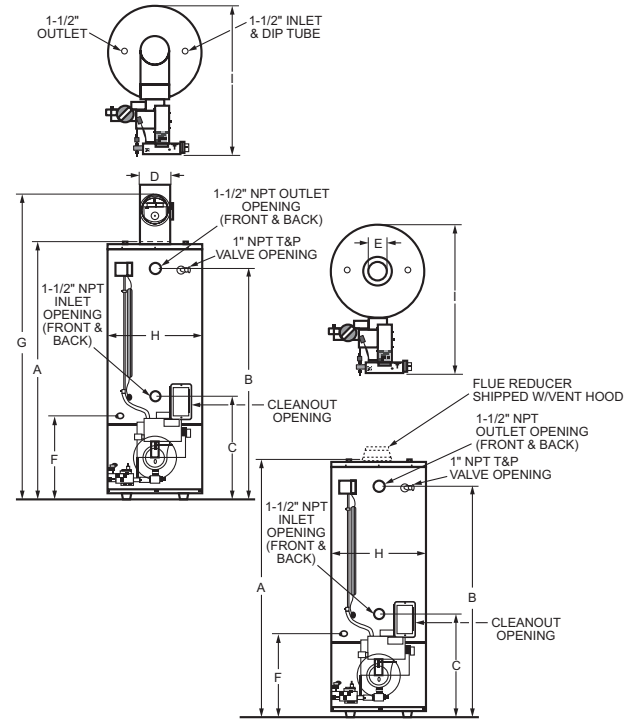

Model Number	Dimensions in Inches				
	A	B	C	D	E
GP685 540NEA	80-3/4	73	32-1/4	9	26-1/2
GP685 650NEA	80-3/4	73	32-1/4	9	26-1/2
GP685 740NEA	80-3/4	73	32-1/4	9	26-1/2

Model Number	Dimensions in Inches			
	F	G	H	I
GP685 540NEA	26-1/2	93	29-1/2	48-1/2
GP685 650NEA	26-1/2	93	29-1/2	48-1/2
GP685 740NEA	26-1/2	93	29-1/2	48-1/2

Not available in propane (LP).

Vent Kit included in unit price when ordered with heater.

Authorized start-up service included; required to activate warranty. (Continental U.S. only).

For direct vent or sidewall change the last letter in the model to "V" (example: GPV85 540NEA).

STATE TITAN® LV POWER GAS

HEAVY-DUTY TPG



POWER GAS BURNER

- Suitable for natural or propane gas
- Electronic flame safeguard control with intermittent spark ignition
- Main and pilot automatic gas valves with gas pressure regulators
- Diaphragm air switch for proof of blower operation
- Flame inspection port

FULLY AUTOMATIC CONTROLS WITH SAFETY SHUTOFF

- High-temperature limit control (manual reset)
- CSA certified and ASME rated T&P relief valve
- Hinged door control compartment with key lock for ease of access.
- Two thermostats, upper and lower, for accurate temperature control.
- Standard control is for 120°-180°F water service
- Factory-installed low-water cutoff

BLUE DIAMOND® GLASS COATING

- Provides superior corrosion resistance compared to the industry-standard glasslining.

CODES AND STANDARDS

- Design-certified by UL (Underwriters Laboratories), according to ANSI Z21. 10.3-4.3 CSA Standards
- Meets the thermal efficiency and standby loss requirements of the U.S. Department of Energy and current edition of ASHRAE/IES 90.1

Model Number	Gallon Capacity	Input BTU/HR	Recovery Capacity GPH @ 100°F Rise	Approx. Shipping Weight (lbs)
TPG150 140NEA	163	140,000	136	1292
TPG150 199NEA	163	199,000	193	1292
TPG150 255NEA	163	255,000	247	1292
TPG150 270NEA	163	270,000	262	1397
TPG150 400NEA	151	400,000	388	1397
TPG150 540NEA	151	540,000	524	1505
TPG150 720NEA	145	720,000	698	1510
TPG200 300NEA	221	300,000	291	2098
TPG200 600NEA	221	600,000	582	2098
TPG200 800NEA	221	800,000	776	2103
TPG200 1000NEA	221	1,000,000	970	2103
TPG200 1250NEA	210	1,250,000	1212	2467
TPG200 1500NEA	201	1,500,000	1454	2757
TPG300 300NEA	300	300,000	291	2150
TPG300 600NEA	300	600,000	582	2150
TPG300 800NEA	411	800,000	776	2308
TPG300 1000NEA	411	1,000,000	970	2308
TPG300 1250NEA	411	1,250,000	1212	2584
TPG300 1500NEA	411	1,500,000	1454	2774
TPG400 600NEA	411	800,000	776	3207
TPG400 800NEA	411	800,000	776	3212
TPG400 1000NEA	411	1,000,000	970	3212
TPG400 1250NEA	411	1,250,000	1212	3212
TPG400 1500NEA	411	1,500,000	1454	3528
TPG400 1750NEA	404	1,750,000	1697	3669
TPG400 2000NEA	397	2,000,000	1939	3667
TPG600 720NEA	594	720,000	698	3667
TPG600 1000NEA	594	1,000,000	970	3667
TPG600 1250NEA	594	1,250,000	1212	3667
TPG600 1500NEA	594	1,500,000	1454	3837
TPG600 1750NEA	594	1,750,000	1697	3837
TPG600 2000NEA	594	2,000,000	1939	3837
TPG600 2250NEA	585	2,250,000	2182	4477
TPG600 2500NEA	575	2,500,000	2424	4619

Optional Low Nox Burners		VTPN/NMP Motor HP
Available Low Nox Burner BTU Input Sizes (Nat. Gas Only)	BTUH	
	400,000	1/4 HP
	540,000	
	600,000	
	720,000	
	800,000	1/2 HP
	1,000,000	
	1,250,000	
	1,500,000	1 HP
	1,750,000	
2,000,000		

Low NOx not available in LP.

Change G to X when ordering Low NOx units. Example TPX140 400NE

Specify when ordering propane (LP) gas.

Change G to X when ordering Low NOx units. Example TPX140 400NE

Dimensions and Line Drawings on the following pages.

STATE TITAN® LV POWER GAS

HEAVY-DUTY TPG (CONTINUED)

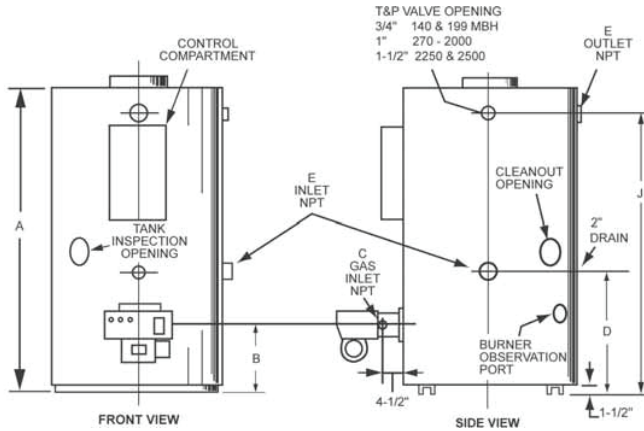
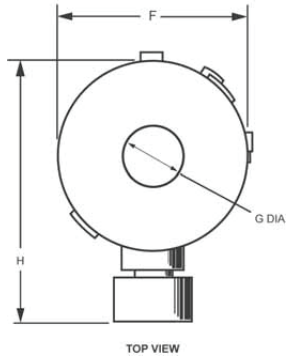

Model Number	Dimensions in Inches								
	A	B	C	D	E	F	G	H	J
TPG150 140NEA	82-1/4	13-1/2	1/2	29-1/4	1-1/4	36-1/2	5	47	73-1/2
TPG150 199NEA	82-1/4	13-1/2	1/2	29-1/4	1-1/4	36-1/2	6	47	73-1/2
TPG150 255NEA	82-1/4	13-1/2	1/2	29-1/4	1-1/4	36-1/2	6	47	73-1/2
TPG150 270NEA	82-1/4	13-1/2	1	29-1/4	1-1/4	36-1/2	6	57-1/2	73-1/2
TPG150 400NEA	82-1/4	13-1/2	1	29-1/4	1-1/4	36-1/2	7	57-1/2	73-1/2
TPG150 540NEA	82-1/4	13-1/2	1	29-1/4	1-1/4	36-1/2	8	57-1/2	73-1/2
TPG150 720NEA	82-1/4	13-1/2	1-1/4	29-1/4	1-1/4	36-1/2	10	57-1/2	73-1/2
TPG200 300NEA	84-1/2	17-1/2	1	34-3/4	1-1/2	44-3/4	6	66-1/2	74-3/4
TPG200 600NEA	84-1/2	17-1/2	1	34-3/4	1-1/2	44-3/4	8	66-1/2	74-3/4
TPG200 800NEA	84-1/2	17-1/2	1-1/4	34-3/4	1-1/2	44-3/4	10	66-1/2	74-3/4
TPG200 1000NEA	84-1/2	17-1/2	1-1/4	34-3/4	1-1/2	44-3/4	10	66-1/2	74-3/4
TPG200 1250NEA	84-3/4	13-1/2	1-1/4	29-1/2	1-1/2	44-3/4	12	66-1/2	75
TPG200 1500NEA	84-3/4	13-1/2	1-1/2	29-1/2	1-1/2	44-3/4	12	81-1/2	75
TPG300 300NEA	92	14	1	29-1/4	1-1/2	44-3/4	6	66-1/2	82-1/2
TPG300 600NEA	92	14	1	29-1/4	1-1/2	44-3/4	8	66-1/2	81-1/2
TPG300 800NEA	92	14	1-1/4	29-1/4	1-1/2	44-3/4	10	66-1/2	81-1/2
TPG300 1000NEA	92	14	1-1/4	29-1/4	1-1/2	44-3/4	10	66-1/2	81-1/2
TPG300 1250NEA	92	14	1-1/4	29-1/4	1-1/2	44-3/4	12	66-1/2	81-1/2
TPG300 1500NEA	92	14	1-1/2	29-1/4	1-1/2	44-3/4	12	81-1/2	81-1/2
TPG400 600NEA	89	17-1/2	1	33-1/4	2	55	8	76-1/2	78-3/4
TPG400 800NEA	89	17-1/2	1-1/4	33-1/4	2	55	10	76-1/2	78-3/4
TPG400 1000NEA	89	17-1/2	1-1/4	33-1/4	2	55	10	76-1/2	78-3/4
TPG400 1250NEA	89	17-1/2	1-1/4	33-1/4	2	55	12	76-1/2	78-3/4
TPG400 1500NEA	89	17-1/2	1-1/2	33-1/4	2	55	12	91-1/2	78-3/4
TPG400 1750NEA	89	17-1/2	2	33-1/4	2	55	14	91-1/2	78-3/4
TPG400 2000NEA	96-1/4	17-1/2	2	33-1/4	2	55	14	91-1/2	86-1/2
TPG600 720NEA	114	17-1/2	1-1/4	33-1/4	2	55	10	76-1/2	105
TPG600 1000NEA	114	17-1/2	1-1/4	33-1/4	2	55	10	76-1/2	105
TPG600 1250NEA	114	17-1/2	1-1/4	33-1/4	2	55	12	76-1/2	105
TPG600 1500NEA	114	17-1/2	1-1/2	33-1/4	2	55	12	91-1/2	105
TPG600 1750NEA	114	17-1/2	2	33-1/4	2	55	14	91-1/2	105
TPG600 2000NEA	114	17-1/2	2	33-1/4	2	55	14	91-1/2	105
TPG600 2250NEA	114	17-1/2	2	33-1/4	2	55	16	91-1/2	105
TPG600 2500NEA	114	17-1/2	2	33-1/4	2	55	14	91-1/2	105

Specify when ordering propane (LP) gas.

Change G to X when ordering Low NOx units. Example TPX140 400NE

STATE TITAN® LV POWER OIL

HEAVY-DUTY OIL-FIRED LARGE VOLUME



FULLY AUTOMATIC CONTROLS WITH SAFETY SHUTOFF

- High temperature limit control (manual reset). CSA Certified and ASME rated temperature and pressure relief valve.
- Hinged door control compartment with key lock for ease of access.
- Two thermostats, upper and lower, for accurate temperature control.

JACKET AND INSULATION

- Heavy gauge steel jacket with baked powder coat finish.
- Insulated with high-density foam insulation that meets or exceed all required standards.
- Meets or exceeds the thermal efficiency and/or standby loss requirements of the U.S.
- Department of Energy and current edition ASHRAE/IES 90.1.

3-YEAR LIMITED TANK AND 1-YEAR LIMITED PARTS WARRANTY

- For complete warranty information consult written warranty or go to statewaterheaters.com



Model Number	Gallon Capacity	Input Rating BTU/HR	Recovery Capacity GPH @ 100°F Rise
COF-150-140	163	140,000	136
COF-150-199	163	199,000	193
COF-150-255	163	255,000	247
COF-150-270	163	270,000	262
COBT-150-350	150	350,000	339
COF/COBT-150-400	151	400,000	387
COF/COBT-150-540	151	540,000	524
COF/COBT-150-720	145	720,000	698
COF/COBT-200-300*	221	300,000	291
COF/COBT-200-600	221	600,000	582
COF/COBT-200-800	221	800,000	776
COF/COBT-200-1000	201	1,000,000	970
COF/COBT-200-1250	201	1,250,000	1212
COF/COBT-200-1500	201	1,500,000	1455
COF/COBT-300-300*	300	300,000	291
COF/COBT-300-600	300	600,000	582
COF/COBT-300-800	300	800,000	776
COF/COBT-300-1000	300	1,000,000	970
COF/COBT-300-1250	300	1,250,000	1212
COF/COBT-300-1500	300	1,500,000	1455
COF/COBT-400-600	411	600,000	582
COF/COBT-400-800	411	800,000	776
COF/COBT-400-1000	411	1,000,000	970
COF/COBT-400-1250	411	1,250,000	1212
COF/COBT-400-1500	397	1,500,000	1455
COF/COBT-400-1750	397	1,750,000	1697
COF/COBT-400-2000	397	2,000,000	1939
COF/COBT-600-720	594	720,000	698
COF/COBT-600-1000	594	1,000,000	970
COF/COBT-600-1250	594	1,250,000	1212
COF/COBT-600-1500	594	1,500,000	1455
COF/COBT-600-1750	594	1,750,000	1697
COF/COBT-600-2000	594	2,000,000	1939
COF/COBT-600-2250	575	2,250,000	2182
COF/COBT-600-2500	575	2,500,000	2424

Authorized start-up service included; required to activate warranty.

Consult local factory representative. (Continental U. S. Only).

Specify when ordering propane (LP) gas.

*COBT models are 350,000 BTU.

STATE TITAN® LV POWER OIL

HEAVY-DUTY OIL-FIRED LARGE VOLUME (CONTINUED)

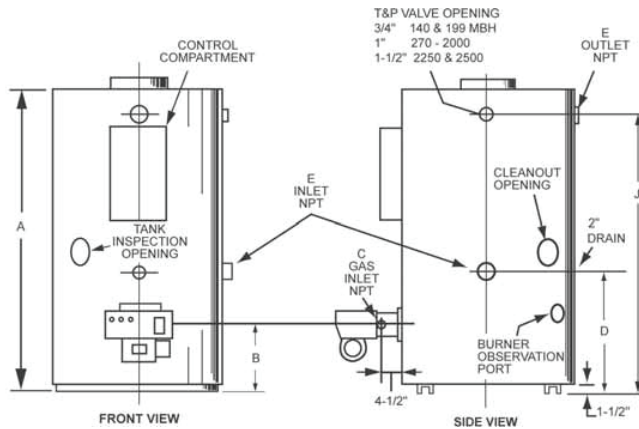
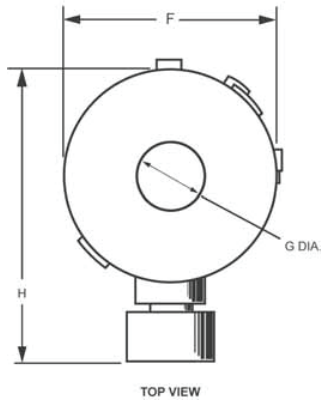

Model Number	Dimensions in Inches									
	A	B	C	D	E	F	G	H	J	
COF-150-140	82-1/4	13-1/2	1/2	29-1/4	1-1/4	36-1/2	5	47	73-1/2	
COF-150-199	82-1/4	13-1/2	1/2	29-1/4	1-1/4	36-1/2	6	47	73-1/2	
COF-150-255	82-1/4	13-1/2	1/2	29-1/4	1-1/4	36-1/2	6	47	73-1/2	
COF-150-270	82-1/4	13-1/2	1	29-1/4	1-1/4	36-1/2	6	57-1/2	73-1/2	
COBT-150-350	82-1/4	13-1/2	1	29-1/4	1-1/4	36-1/2	7	57-1/2	73-1/2	
COF/COBT-150-400	82-1/4	13-1/2	1	29-1/4	1-1/4	36-1/2	7	57-1/2	73-1/2	
COF/COBT-150-540	82-1/4	13-1/2	1	29-1/4	1-1/4	36-1/2	8	57-1/2	73-1/2	
COF/COBT-150-720	82-1/4	13-1/2	1-1/4	29-1/4	1-1/4	36-1/2	10	57-1/2	73-1/2	
COF/COBT-200-300*	84-1/2	17-1/2	1	34-3/4	1-1/2	44-3/4	6	66-1/2	74-3/4	
COF/COBT-200-600	84-1/2	17-1/2	1	34-3/4	1-1/2	44-3/4	8	66-1/2	74-3/4	
COF/COBT-200-800	84-1/2	17-1/2	1-1/4	34-3/4	1-1/2	44-3/4	10	66-1/2	74-3/4	
COF/COBT-200-1000	84-1/2	17-1/2	1-1/4	34-3/4	1-1/2	44-3/4	10	66-1/2	74-3/4	
COF/COBT-200-1250	84-3/4	13-1/2	1-1/4	29-1/2	1-1/2	44-3/4	12	66-1/2	75	
COF/COBT-200-1500	84-3/4	13-1/2	1-1/4	29-1/2	1-1/2	44-3/4	12	81-1/2	75	
COF/COBT-300-300*	92	14	1	29-1/4	1-1/2	44-3/4	6	66-1/2	81-1/2	
COF/COBT-300-600	92	14	1	29-1/4	1-1/2	44-3/4	8	66-1/2	81-1/2	
COF/COBT-300-800	92	14	1-1/4	29-1/4	1-1/2	44-3/4	10	66-1/2	81-1/2	
COF/COBT-300-1000	92	14	1-1/4	29-1/4	1-1/2	44-3/4	10	66-1/2	81-1/2	
COF/COBT-300-1250	92	14	1-1/4	29-1/4	1-1/2	44-3/4	12	66-1/2	81-1/2	
COF/COBT-300-1500	92	14	1-1/4	29-1/4	1-1/2	44-3/4	12	81-1/2	81-1/2	
COF/COBT-400-600	89	17-1/2	1	33-1/4	2	55	8	76-1/2	78-3/4	
COF/COBT-400-800	89	17-1/2	1-1/4	33-1/4	2	55	10	76-1/2	78-3/4	
COF/COBT-400-1000	89	17-1/2	1-1/4	33-1/4	2	55	10	76-1/2	78-3/4	
COF/COBT-400-1250	89	17-1/2	1-1/4	33-1/4	2	55	12	76-1/2	78-3/4	
COF/COBT-400-1500	89	17-1/2	1-1/4	33-1/4	2	55	12	91-1/2	78-3/4	
COF/COBT-400-1750	89	17-1/2	2	33-1/4	2	55	14	91-1/2	78-3/4	
COF/COBT-400-2000	96-1/4	17-1/2	2	33-1/4	2	55	14	91-1/2	86-1/2	
COF/COBT-600-720	114	17-1/2	1-1/4	33-1/4	2	55	10	76-1/2	108	
COF/COBT-600-1000	114	17-1/2	1-1/4	33-1/4	2	55	10	76-1/2	105	
COF/COBT-600-1250	114	17-1/2	1-1/4	33-1/4	2	55	12	76-1/2	105	
COF/COBT-600-1500	114	17-1/2	1-1/2	33-1/4	2	55	12	91-1/2	105	
COF/COBT-600-1750	114	17-1/2	2	33-1/4	2	55	14	91-1/2	105	
COF/COBT-600-2000	114	17-1/2	2	33-1/4	2	55	14	91-1/2	105	
COF/COBT-600-2250	114	17-1/2	2	33-1/4	2	55	16	91-1/2	105	
COF/COBT-600-2500	114	17-1/2	2	33-1/4	2	55	16	91-1/2	105	

Authorized start-up service included; required to activate warranty.
Consult local factory representative. (Continental U. S. Only).
Specify when ordering propane (LP) gas.

*COBT models are 350,000 BTU.

STATE TITAN® POWER BURNER GPO SERIES OIL



EFFICIENT COMBUSTION CHAMBER

- Precast, high temperature combustion chamber made of alumina silica ceramic fiber. Engineered for maximum insulation and heat reflection. Unique design assures more complete combustion by stabilizing flame pattern.

BAROMETRIC DRAFT REGULATOR

FLAME OBSERVATION PORT

- Permits Convenient Flame Check

TWO HAND-HOLE CLEANOUTS

- Allows easy cleaning on standard models GPO75 385 OE(A) and larger and ASME models

EASY-TO-INSTALL BURNER

- Three bolt mounting of burner assures easy installations.

3-YEAR LIMITED TANK AND 1-YEAR LIMITED PARTS WARRANTY

- For complete warranty information consult written warranty or go to statewaterheaters.com



Model Number	Gallon Capacity	Input BTU/HR	Recovery Capacity GPH @ 100°F Rise*	Motor HP	Approx. Shipping Weight (lbs)	
					Standard	ASME
GP086 199 OE	86	199,000	191	1/8	553	N/A
GP086 245 OE	86	245,000	235	1/8	554	N/A
GP084 315 OE(A)	84	315,000	302	1/8	554	657
GP075 385 OE(A)	75	385,000	369	1/8	624	742
GP075 455 OE(A)	75	455,000	436	1/8	700	747
GP069 700 OE(A)	69	700,000	671	1/8	739	822

Model Number	Dimensions in Inches					
	A	B	C	D	E	F
GP086 199 OE	74-1/2	36-3/4	27-3/4	2	3/4 NPT	6
GP086 245 OE	74-1/2	36-3/4	27-3/4	2	3/4 NPT	8
GP084 315 OE(A)	74-1/2	36-3/4	27-3/4	2	3/4 NPT	8
GP075 385 OE(A)	73-3/4	36-3/4	27-3/4	2	3/4 NPT	8
GP075 455 OE(A)	73-3/4	36-3/4	27-3/4	2	3/4 NPT	8
GP069 700 OE(A)	73-3/4	36-3/4	27-3/4	2	3/4 NPT	10

Model Number	Dimensions in Inches				
	G	H	J	K	L
GP086 199 OE	26-5/8	74-1/2	1-1/2 NPT	1-1/2 NPT	22-3/4
GP086 245 OE	26-5/8	74-1/2	1-1/2 NPT	1-1/2 NPT	22-3/4
GP084 315 OE(A)	26-5/8	74-1/2	1-1/2 NPT	1-1/2 NPT	22-3/4
GP075 385 OE(A)	24-3/4	73-3/4	1-1/2 NPT	1-1/2 NPT	23-7/16
GP075 455 OE(A)	24-3/4	73-3/4	1-1/2 NPT	1-1/2 NPT	23-7/16
GP069 700 OE(A)	30-3/16	79-3/16	1-1/2 NPT	1-1/2 NPT	28-7/8

ASME models have "A" at the end of the model number

Based on No. 2 fuel oil. All models have 1/8 HP motor.

Burner and Barometric packaged separately.

Authorized start-up service included - Required to activate warranty, contact factory

Electrical characteristics 120V, 60Hz A.C.

1" N.P.T. T & P RELIEF VALVE
(FRONT OF HEATER)

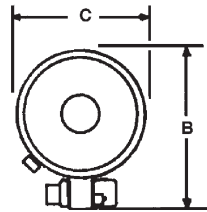
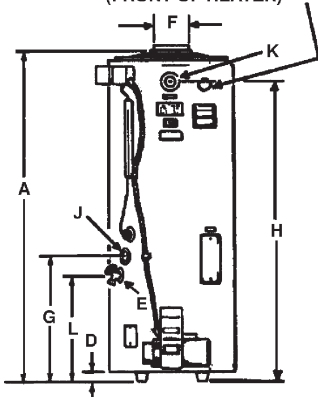

PATRIOT™

LIGHT-SERVICE ELECTRIC



Designed for light duty commercial applications with intermittent hot water loads

GLASSLINED TANK

- Tank interior is coated with glass specially designed by State Water Heaters for water heater use.

HEATING ELEMENTS

- Two 4.5 KW zinc plated copper sheathed elements are standard.

STANDARD VOLTAGES

- The standard voltage is 240V single phase.

TOP MOUNTED RECESSED JUNCTION BOX

CONTROLS

- Thermostat is adjustable through a range of 120° to 181°F with a manual reset high temperature cutoff. The heater is wired for non-simultaneous single phase operation.

COREGARD™ ANODE ROD

- Our anode rods have a stainless steel core that extends the life of the anode rod allowing superior tank protection for longer than standard anode rods.

ENHANCED-FLOW BRASS DRAIN VALVE

- Solid brass, tamper resistant, enhanced-flow, ball type, drain valve.

MAXIMUM WORKING PRESSURE 150 PSI

FACTORY INSTALLED CSA CERTIFIED AND ASME RATED TEMPERATURE AND PRESSURE RELIEF VALVE

CERTIFIED TO UL 1453 FOR COMMERCIAL ELECTRIC WATER HEATERS

COMPLIANCE

- Meets the standby loss requirements of the U.S. Department of Energy and current edition of ASHRAE/IES 90.1.

WARRANTY

- 3-year limited tank/1-year limited parts.
- For complete information consult the written warranty or statewaterheaters.com.

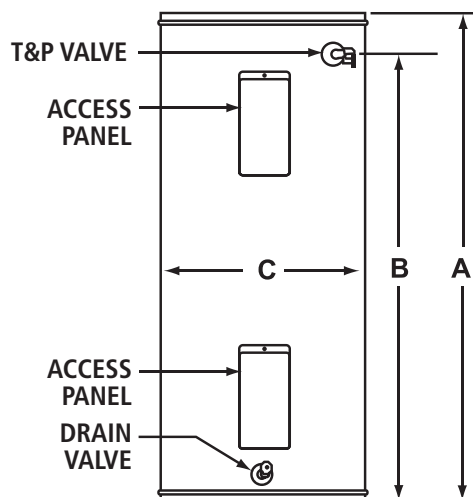
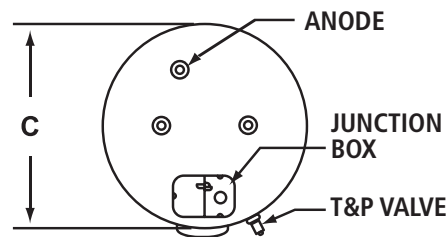

Model Number	Gallon Capacity	Standard Element Wattage 240 VAC	Dimensions in Inches				Approx. Shipping Weight (lbs)
			A	B	C	D	
EDT 6620RT	66	4500	60-1/4	53	22	8	146
EDT 8020RT	80	4500	60-1/2	52-1/4	24	8	175
EDT 12020RT	119	4500	61-1/2	54-1/2	28	8	268

Not available with top mounted T&P valve option

PATRIOT™

LIGHT-DUTY ELECTRIC



GLASSLINED TANK

- Thirteen sizes, 6 thru 119 gallon capacity.
- Tank interior is coated with glass specially designed by State for water heater use.

ELEMENTS

- Zinc plated copper sheaths for longer life. Medium watt density means lower surface temperature to minimize scale build-up and more surface to heat water. Element sizes from 1.5 to 6 KW. Maximum input 12 KW

STANDARD VOLTAGES

- 120, 277 single phase and 208, 240 and 480V unbalanced three-phase delta; easily converted to single-phase at terminal block (except 208V with 6000 watt elements).

- Single element heater, single-phase only.

TERMINAL BLOCK

- Factory-installed. Just bring the service to heater and connect to block. Terminal block not supplied on 120V & 277 volt models.

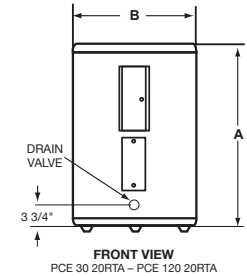
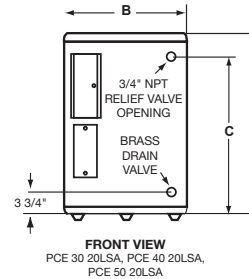
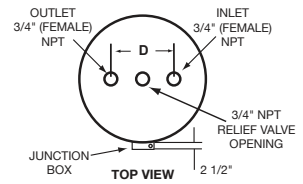
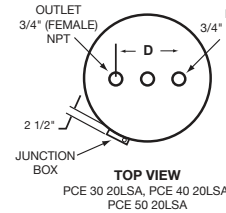
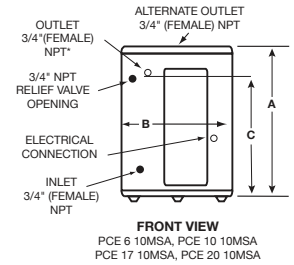
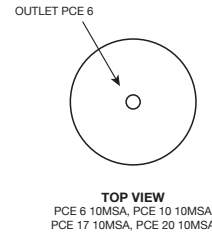

Element Wattage (Upper/Lower)	U. S. Gallons/Hr at Temperature Rise Indicated	
	F°	100
Non-Simultaneous Operation		
/1500	GPH	6
/2000	GPH	8
/2500	GPH	10
3000/3000	GPH	12
4000/4000	GPH	16
4500/4500	GPH	18
5000/5000	GPH	20
6000/6000	GPH	24
Simultaneous Operation		
3000/3000	GPH	24
4000/4000	GPH	32
4500/4500	GPH	36
5000/5000	GPH	41
6000/6000	GPH	49

Model Number	No. of Elements	Tank Capacity U.S. Gals.	A	B	C	D	Approx. Shipping Weight lbs.
			Inches	Inches	Inches	Inches	
PCE 6 10MSA	1	6	15-1/2	14-1/4	11	N/A	35
PCE 10 10MSA	1	10	18-1/4	18	12-1/2	N/A	54
PCE 17 0MSA	1	15	26	18	20-1/2	N/A	58
PCE 20 10MSA	1	20	22-1/4	21-3/4	15-3/8	N/A	73
PCE 30 20LSA	2	30	30-7/8	21-3/4	24-1/8	8	100
PCE 40 20LSA	2	40	32-1/4	24	25-9/16	8	125
PCE 50 20LSA	2	50	32-1/4	26-1/2	25-1/8	8	166
PCE 30 20RTA	2	30	34-1/2	20-1/2	N/A	8	98
PCE 40 20RTA	2	40	45-1/8	20-1/2	N/A	8	113
PCE 52 20RTA	2	50	54-7/8	20-1/2	N/A	8	131
PCE 66 20RTA	2	66	60-3/4	21-3/4	N/A	8	176
PCE 82 20RTA	2	80	59-3/8	24	N/A	8	211
PCE 120 20RTA	2	119	62-7/16	29-3/8	N/A	8	326

SANDBLASTER®

IMMERSION MOUNT THERMOSTAT-CSB SERIES



ADVANCED ELECTRONIC CONTROL

- Plain English Text and Animated Icons Display Diagnostics

ECONOMY MODE OPERATION LOWERS THE OPERATING SET POINT AND REDUCES OPERATING COSTS

THERMOSTATIC LINEAR SEQUENCING CONTROL HELPS REDUCE CURRENT SURGES AND PROVIDES ACCURATE CONTROL OF WATER TEMPERATURE

GOLDENROD ELEMENTS

- All CSB models ship standard with patented Goldenrod 24K gold plated elements. Goldenrod elements provide long life with superior scaling resistance.

3-YEAR LIMITED TANK AND 1-YEAR LIMITED PARTS WARRANTY

- For complete warranty information, consult written warranty or go to statewaterheaters.com

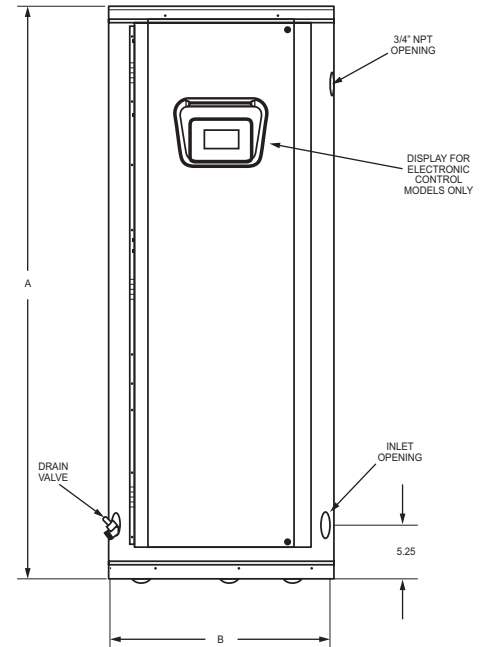
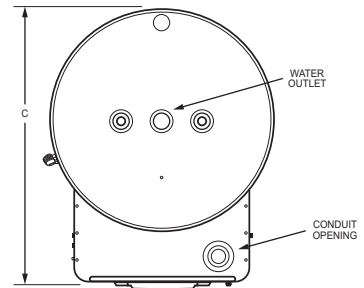

Model Number	Gallon Capacity	Dimensions in Inches			Approx. Shipping Weight
		A	B	C	
CSB-52	50	55-3/4	21-3/4	27	265
CSB-80	80	60-1/4	25-1/2	31	280
CSB-120	119	62-1/4	29-1/2	35	390

See specification sheets or contact your local rep for optional kW's available.
208 volt models may use three additional elements. 54 kW not available in 208 single phase.

SANDBLASTER®

SURFACE MOUNT THERMOSTATS - CSB SERIES



GOLD ELEMENTS

- CSB models ship with the Goldenrod 24K gold plated elements (see spec sheet for kw options).
- Patented Goldenrod elements provide long life and superior scaling resistance.
- Low watt density means lower surface temperature to minimize scale buildup and more surface to heat water. Goldenrod elements carry a one-year warranty against failure due to lime scale buildup.

FUSING

- Protects all elements, thermostats, and internal wiring circuits against excess current flow.
- Meets National Electrical Code requirements that non-ASME tanks must have internal fusing when current draw exceeds 48 amps. Available as an option on Canadian built heaters
- Standard Voltages 208, 240, 277, 480V single-phase and three phase delta. Convertible from three-phase to single-phase (in Field) and Vice Versa (except 208/54kW) 277 single-phase only.

ELEMENT AVAILABILITY

- CSB heaters available from 3kw to 54 KW with recoveries of 25 to 837 GPH at a 100°F rise. (CSB-52 has 36kw max).

MEETS THE STANDBY LOSS REQUIREMENTS OF THE U.S. DEPARTMENT OF ENERGY AND CURRENT EDITION OF ASHRAE/IES 90.1.

3-YEAR LIMITED TANK AND 1-YEAR LIMITED PARTS WARRANTY

- For complete warranty information, consult written warranty or go to statewaterheaters.com

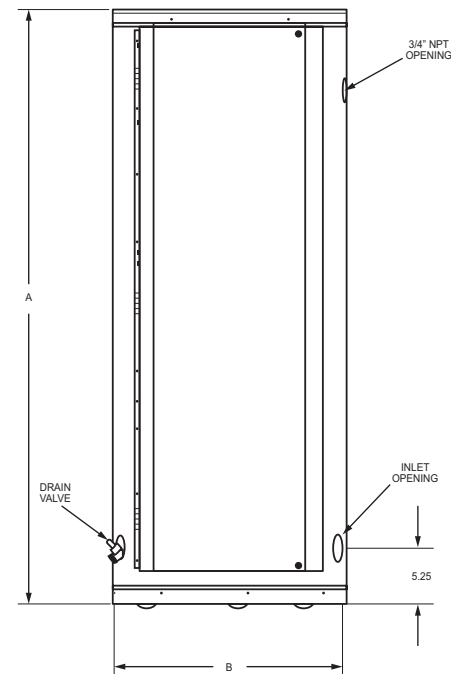
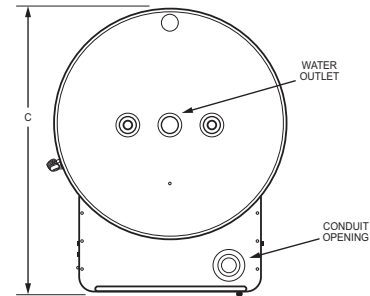

Model Number	Tank Capacity		Dimensions						Inlet/Outlet (NPT)		Approx. Shipping Weight	
			A		B		C					
	gal.	litre	Inches	cm	Inches	cm	Inches	cm	Inches	cm	lbs	kg
CSB-52**	50	189	55-3/4	142	21-3/4	55.2	27	68.6	1-1/4	3.2	265	120
CSB-80	80	300	60-1/4	153	25-1/2	64.8	31	78.7	1-1/4	3.2	280	127
CSB-120	119	450	62-1/4	158.1	29-1/2	75	35	88.9	1-1/4	3.2	390	177

208 volt models may use three additional elements. 54 kW not available in 208 single phase.
For ASME tank construction add "A" to the model number.

**CSB-52 is maximum 36kW.



ADVANCED ELECTRONIC CONTROL

- Provides Precise Temperature Control and Plain English Text with Animated Icons Displayed

LOW-WATER CUTOFF-REMOTE ELECTRONIC IMMERSION-TYPE PROBE TO PREVENT ENERGIZING OF THE ELEMENTS, ELIMINATING ACCIDENTAL DRY FIRING

INCOLOY-SHEATH HEATING ELEMENTS STANDARD

FACTORY-WIRED, 120V CIRCUIT CONTROLS

POWER-CIRCUIT FUSING FOR SYSTEM PROTECTION

GLASS-LINED TANK WITH ASME CONSTRUCTION

CSA CERTIFIED AND ASME RATED T&P RELIEF VALVE

BACNET AND MODBUS COMPATIBLE WITH ICC INTERFACE

3-YEAR LIMITED TANK AND 1-YEAR LIMITED PARTS WARRANTY

- For complete warranty information, consult written warranty or go to staterwaterheaters.com

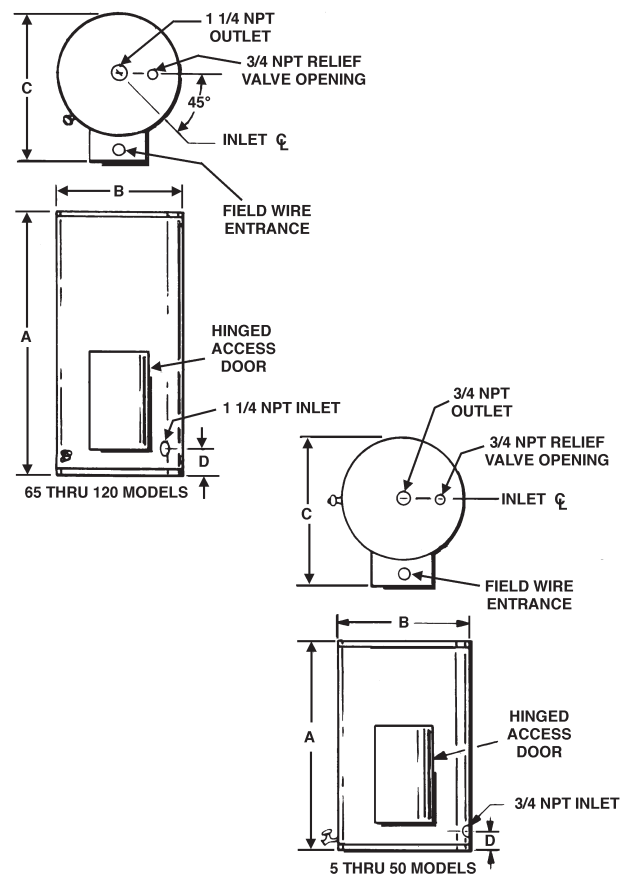

Model Number	Tank Capacity Gallons	Maximum kW Input	Dimensions in Inches				Approx. Shipping Weight (lbs.)
			A	B	C	D	
SSE-5	5	3	20-1/4	16-1/4	22-1/2	5-1/4	82
SSE-10	10	6	26-1/4	18-3/4	25	5-1/4	116
SSE-20	20	18	27-1/4	20-1/2	26-1/2	5-3/4	145
SSE-30	30	24	35-3/4	20-1/2	26-1/2	5-3/4	150
SSE-40	40	36	45-3/4	20-1/2	26-1/2	5-3/4	190
SSE-50	50	90	54-3/4	20-1/2	26-1/2	5-3/4	221
SSE-65	65	90	54	26-1/2	33-1/2	7	280
SSE-80	80	90	52-1/4	28	35	7	285
SSE-100	100	90	60-1/2	28	35	7	354
SSE-120	120	90	65-1/2	30	37	7-1/2	420

STANDARD JACKETED STORAGE TANKS



GLASSLINED TANK

- Alkaline borosilicate composition permanently fused to steel by firing at a temperature of 1600°F, providing years of corrosion protection and dependable use.

IDEAL FOR USE WITH GAS FIRED COPPER HEAT EXCHANGER EQUIPMENT FOR POTABLE WATER AT TEMPERATURES UP TO 180°F THREADED OPENINGS

- All tanks furnished with threaded openings for thermometer, relief valve, 2" recirculation lines, tankstat, and drain valve.

ASME CONSTRUCTION ON SELECT MODELS

- 160 psi standard working pressure on all ASME models.

ANODIC PROTECTION ALL MODELS

- Magnesium anode for anti-corrosion protection.

MEETS R12.5 MINIMUM THERMAL INSULATION REQUIREMENTS OF THE U.S. DEPARTMENT OF ENERGY AND CURRENT EDITION OF ASHRAE/IES 90.1

5-YEAR LIMITED TANK AND 1-YEAR LIMITED PARTS WARRANTY

- For complete warranty information, consult written warranty or go to staterwaterheaters.com

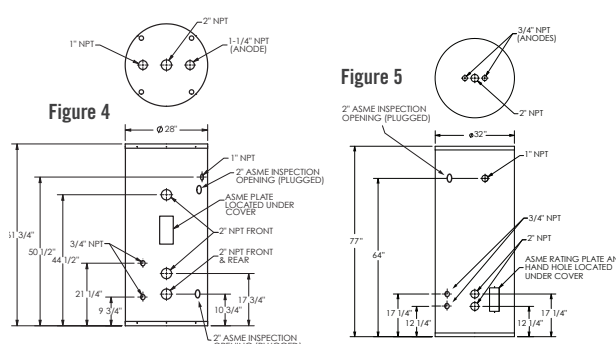
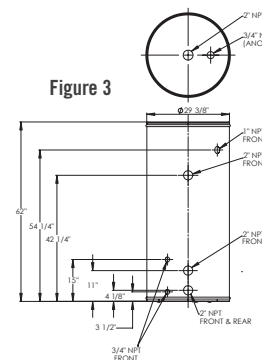
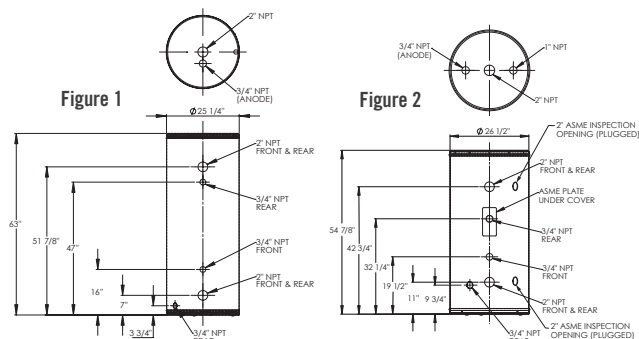

Model Number	Nominal Gallon Capacity	Overall Length (Inches)	Diameter (Inches)	Approx. Shipping Weight (lbs)	Figure
PVG 0080 00VT- Jacketed-Vertical Only	80	63	25-1/4	236	1
PVG 0120 00VT- Jacketed-Vertical Only	119	62	29-3/8	320	2
PVG 0080 00VTA 125	80	54-7/8	26-1/2	369	3
PVG 0120 00VTA 125	119	61-3/4	28	411	4
PVG 0200 00VSA 125	175	77	32	560	5

CUSTOM-LINE FACTORY JACKETED & INSULATED



STANDARD SIZES

- From 140 to 1,000 gallons; all stock tanks glasslined.

HORIZONTAL OR VERTICAL MOUNTING OPTIONS AVAILABLE

HIGH-DENSITY, FIBERGLASS INSULATED JACKETS MEET R12.5 MINIMUM THERMAL INSULATION REQUIREMENTS OF THE U.S. DEPARTMENT OF ENERGY AND CURRENT EDITION OF ASHRAE/IES 90.1

ASME CONSTRUCTION

- Available in 100, 125, 150 and 160 working pressures. 125 standard.

ANODIC PROTECTION

ACCESSORIES

- Tanks will be supplied with the fittings located as indicated on the drawings unless specified otherwise. An 11" x 15" manhole or 4" x 6" handhole is optional on glasslined tanks 36" diameter or less.

CABINET

- Heavy gauge steel with high quality powder coat paint provides additional insulating qualities for greater energy savings.

5-YEAR LIMITED TANK WARRANTY

- For complete warranty information consult written warranty or go to statewaterheaters.com

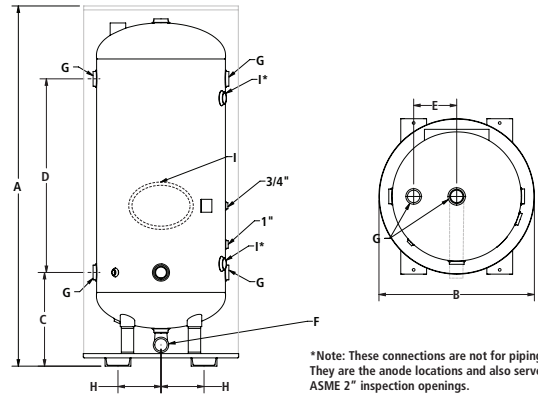

*Note: These connections are not for piping connections. They are the anode locations and also serve as the required ASME 2" inspection openings.

STORAGE TANK SELECTION

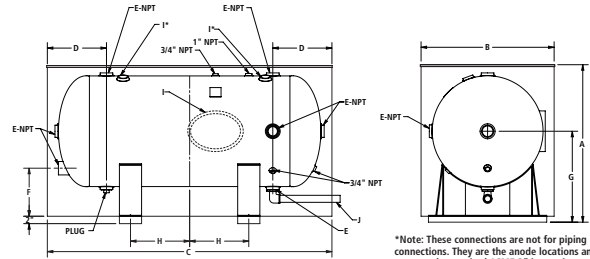

*Note: These connections are not for piping connections. They are the anode locations and also serve as the required ASME 2" inspection openings.

Model Number	Nominal Gallon Capacity	Dimensions in Inches			
		A	B	C	D
PVG 0140 00VTA125	140	87	30	21-1/2	51
†PVG 0200 00VTA125	200	83	36	22	45
PVG 0250 00VTA125	250	96	36	22	58
PVG 0350 00VTA125	350	97	42	24-1/2	54
PVG 0400 00VTA125	400	105	42	24-1/2	61
PVG 0500 00VTA125	500	100	48	27	52
PVG 0500 00VSA125	500	84	54	27-3/4	33-1/4
PVG 0750 00VTA125	750	116	54	27-3/4	65-1/2
PVG 1000 00VTA125	1,000	150	54	27-3/4	97-1/2

Model Number	Dimensions in Inches				"I" ASME Inspection Openings
	E	F	G	H	
PVG 0140 00VTA125	8	1-1/2	2-1/2	6-3/8	2
†PVG 0200 00VTA125	10	1-1/2	2-1/2	7-3/4	2
PVG 0250 00VTA125	10	1-1/2	2-1/2	7-3/4	2
PVG 0350 00VTA125	14	1-1/2	2-1/2	9-1/2	2
PVG 0400 00VTA125	14	1-1/2	2-1/2	9-1/2	2
PVG 0500 00VTA125	16	1-1/2	3	11-5/16	12 x 16
PVG 0500 00VSA125	18	1-1/2	3	12-3/4	12 x 16
PVG 0750 00VTA125	18	1-1/2	3	12-3/4	12 x 16
PVG 1000 00VTA125	18	1-1/2	3	12-3/4	12 x 16

Continued on the following page.

CUSTOM-LINE FACTORY JACKETED & INSULATED (CONTINUED)

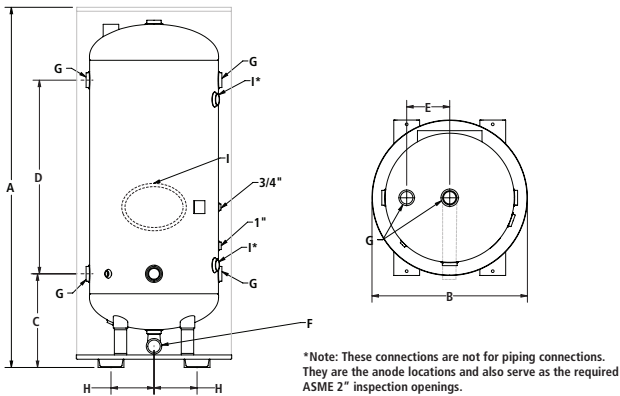

STORAGE TANK SELECTION

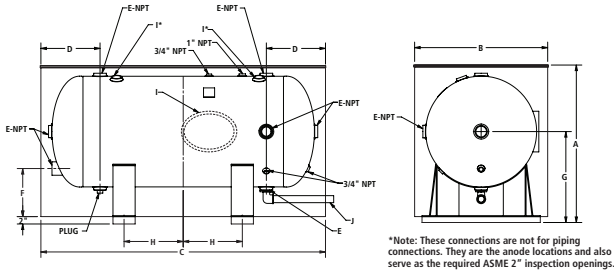

Model Number	Nominal Gallon Capacity	Dimensions in Inches				
		A	B	C	D	E
†PVG 0200 00HTA125	200	41	36	77	16	2-1/2
PVG 0250 00HTA125	250	41	36	90	15	2-1/2
PVG 0350 00HTA125	350	47	42	93	17-1/2	2-1/2
PVG 0400 00HTA125	400	47	42	99	17-1/2	2-1/2
PVG 0500 00HTA125	500	53	48	94	21	3
PVG 0500 00VSA125	500	59	54	79	22-3/4	3
PVG 0750 00HTA125	750	59	54	111	22-3/4	3
PVG 1000 00HTA125	1,000	59	54	143	22-3/4	3

Model Number	Nominal Gallon Capacity	Dimensions in Inches				
		F	G	H	"1" ASME Inspection Openings	J
†PVG 0200 00HTA125	200	11	23	16	2	1-1/2
PVG 0250 00HTA125	250	11	23	22-1/2	2	1-1/2
PVG 0350 00HTA125	350	10	26	22-1/2	2	1-1/2
PVG 0400 00HTA125	400	10	26	26	2	1-1/2
PVG 0500 00HTA125	500	11	29	19-1/2	12 x 16	1-1/2
PVG 0500 00VSA125	500	12	32	11	12 x 16	1-1/2
PVG 0750 00HTA125	750	12	32	27	12 x 16	1-1/2
PVG 1000 00HTA125	1,000	11	32	43	12 x 16	1-1/2

UNINSULATED STANDARD STOCK BARE

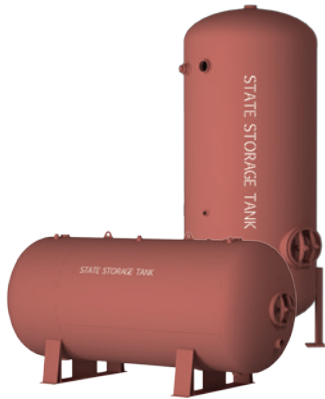

GLASSLINED PER ASME, HLW PROCEDURES

HORIZONTAL AND VERTICAL MOUNTING OPTIONS

HIGH-DENSITY, FIBERGLASS INSULATED JACKETS OR BARE STEEL TANKS

CEMENT OR EPOXY LININGS AVAILABLE

ASME CONSTRUCTION

MAGNESIUM ANODES PROTECT AGAINST CORROSION

MEETS R12.5 MINIMUM THERMAL INSULATION REQUIREMENTS OF THE U.S. DEPARTMENT OF ENERGY AND CURRENT EDITION OF ASHRAE/IES 90.1

5-YEAR LIMITED TANK WARRANTY

- For complete warranty information consult written warranty or go to statewaterheaters.com

Model Number	Gallon Capacity	Overall Dimensions in Inches	Approx. Shipping Weight (lbs)
UVG 0800 00VT	80	20 x 62-18	170
UVG 0120 00VT	119	24-1/4 x 65	287
UVG 0200 00VT	200	30 x 72	460
UVG 0350 00VT	350	36 x 88	670
UVG 0140 00VTA125	140	24 x 76-1/4	400
UVG 0200 00VTA125	200	30 x 72	460
UVG 0250 00VTA125	250	30 x 84	505
UVG 0350 00VTA125	350	36 x 88	670
UVG 0400 00VTA125	400	36 x 97	775
UVG 0500 00VTA125	500	42 x 89	815
UVG 0500 00VTA125	500	48 x 74	950
UVG 0750 00VTA125	750	48 x 106	1290
UVG 01000 00VTA125	1000	48 x 138	1655

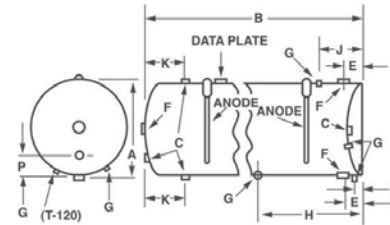

80 AND 120 GALLON MODELS

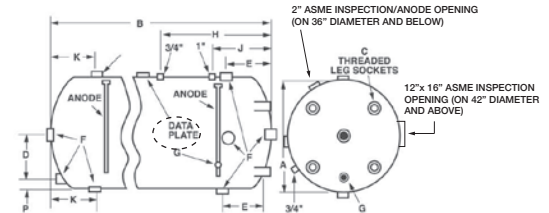

Model Number	Dimensions in Inches					
	A	B	C	D	E	F
UVG 0800 00VT	20	61-1/2	2	N/A	7	2
UVG 0120 00VT	24-1/4	64-3/8	2	N/A	7	2
UVG 0200 00VT	30	70-3/4	2-1/2	10	13	2-1/2
UVG 0350 00VT	36	86	2-1/2	14	16	2-1/2
UVG 0140 00VTA125	24	75	2-1/2	8	12	2-1/2
UVG 0200 00VTA125	30	70-3/4	2-1/2	10	13	2-1/2
UVG 0250 00VTA125	30	84	2-1/2	10	13-1/4	2-1/2
UVG 0350 00VTA125	36	86	2-1/2	14	16	2-1/2
UVG 0400 00VTA125	36	96	2-1/2	14	16	2-1/2
UVG 0500 00VTA125	42	88	3	16	18	3
UVG 0500 00VTA125	48	72-3/4	3	18	18	3
UVG 0750 00VTA125	48	105	3	18	19-3/4	3
UVG 01000 00VTA125	48	136	3	18	19-3/4	3

Model Number	Dimensions in Inches					
	G	H	J	K	N	P
UVG 0800 00VT	3/4	46-1/4	16	3-1/2	3-1/4	4
UVG 0120 00VT	3/4	34-1/2	15-1/2	10-1/2	3-1/2	4-1/8
UVG 0200 00VT	3/4	28-1/2	19-1/2	13	N/A	4
UVG 0350 00VT	3/4	31-1/2	20-1/4	16	N/A	4
UVG 0140 00VTA125	3/4	27-1/2	18-1/2	12	N/A	4
UVG 0200 00VTA125	3/4	28-1/2	19-1/2	13	N/A	4
UVG 0250 00VTA125	3/4	28-1/2	19-1/2	13	N/A	4
UVG 0350 00VTA125	3/4	31-1/2	20-1/4	16	N/A	4
UVG 0400 00VTA125	3/4	31-1/2	20-1/4	16	N/A	4
UVG 0500 00VTA125	3/4	33-1/2	24-1/2	18	N/A	5
UVG 0500 00VTA125	3/4	32-3/4	26-3/4	19-3/4	N/A	6
UVG 0750 00VTA125	3/4	32-3/4	26-3/4	19-3/4	N/A	6
UVG 01000 00VTA125	3/4	32-3/4	26-3/4	19-3/4	N/A	6

HEAVY-DUTY LARGE VOLUME STORAGE TANKS



CUSTOMER BUILT TANKS FROM 80 TO 12,500 GALLONS

HORIZONTAL OR VERTICAL MOUNTING OPTIONS AVAILABLE

HIGH-DENSITY, FIBERGLASS INSULATED JACKETS OR BARE STEEL TANKS

GLASSLINED, CEMENT OR EPOXY LININGS AVAILABLE

ASME CONSTRUCTION

- Available in 125, 150 and 160 psi working pressure.

ANODIC PROTECTION

MANHOLES, HANDHOLES, HEATING COILS, ADDITIONAL TANK OPENING, M LIFTING LUGS, ANGLE LEGS, RING BASES AND HORIZONTAL TANKS SADDLES ALL AVAILABLE AS OPTIONS

MEETS R12.5 MINIMUM THERMAL INSULATION REQUIREMENTS OF THE U.S. DEPARTMENT OF ENERGY AND CURRENT EDITION OF ASHRAE/IES 90.1

5-YEAR LIMITED TANK AND 1-YEAR LIMITED PARTS WARRANTY

- For complete warranty information, consult written warranty or go to statewaterheaters.com



Model Number	Gallon Capacity	Diameter (Inches)	Nominal Approx. O. A. Length	Model Number	Diameter (Inches)	Nominal Approx. O. A. Length	Gallon Capacity
UGV 20 00080 VA125	80	20	60"	UGV 54 00650 VA125	54	71"	650
UGV 20 000100 VA125	100	20	72"	UGV 54 00750 VA125	54	81"	750
UGV 24 00125 VA125	125	24	66"	UGV 54 00900 VA125	54	95"	900
UGV 24 00140 VA125	150	24	75"	UGV 54 01000 VA125	54	105"	1,000
UGV 24 00175 VA125*	175	24	90"	UGV 54 01250 VA125*	54	129"	1,250
UGV 30 00175 VA125	175	30	60"	UGV 54 01500 VA125*	54	153"	1,500
UGV 30 00200 VA125	200	30	71"	UGV 54 01800 VA125*	54	181"	1,800
UGV 30 00250 VA125	250	30	84"	UGV 60 00800 VA125*	60	72"	800
UGV 30 00300 VA125*	300	36	99"	UGV 60 01000 VA125*	60	88"	1,000
UGV 36 00250 VA125	250	36	60"	UGV 60 01250 VA125*	60	107"	1,250
UGV 36 00300 VA125	300	36	71"	UGV 60 01500 VA125*	60	126"	1,500
UGV 36 00350 VA125	350	36	86"	UGV 60 01750 VA125*	60	146"	1,750
UGV 36 00400 VA125	400	36	93"	UGV 60 02000 VA125*	60	165"	2,000
UGV 36 00500 VA125*	500	36	122"	UGV 66 01000 VA125*	66	75"	1,000
UGV 42 00375 VA125	375	42	67"	UGV 66 01500 VA125*	66	107"	1,500
UGV 42 00450 VA125	450	42	79"	UGV 66 02000 VA125*	66	139"	2,000
UGV 42 00500 VA125	500	42	88"	UGV 66 02500 VA125*	66	171"	2,500
UGV 42 00600 VA125	600	42	103"	UGV 72 02500 VA125*	72	147"	2,500
UGV 42 00700 VA125	700	42	119"	UGV 72 03000 VA125*	72	174"	3,000
UGV 42 00800 VA125*	800	42	134"	UGV 72 03500 VA125*	72	201"	3,500
UGV 48 00500 VA125	500	48	73"	UGV 72 04000 VA125*	72	228"	4,500
UGV 48 00600 VA125	600	48	81"	UGV 84 04000 VA125*	84	173"	4,000
UGV 48 00700 VA125	700	48	93"	UGV 84 05000 VA125*	84	212"	5,000
UGV 48 00750 VA125	750	48	105"	UGV 84 06000 VA125*	84	252"	6,000
UGV 48 00900 VA125	900	48	117"	UGV 84 08000 VA125*	84	330"	8,000
UGV 48 01000 VA125	1,000	48	137"	UGV 96 07500 VA125*	96	244"	7,500
UGV 48 01250 VA125	1,250	48	159"	UGV 96 10000 VA125*	96	319"	10,000
UGV 48 01500 VA125	1,500	48	190"	UGV 96 12500 VA125*	96	395"	12,500

HEAVY-DUTY LARGE VOLUME STORAGE TANKS (CONTINUED)



STORAGE TANKS (20" THRU 96" DIA. TANKS)

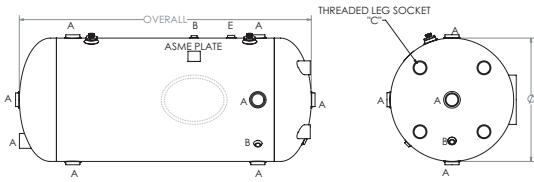

NOTE:

- 1) 54" Diameter and larger tanks must be ordered with angle legs rather than threaded leg sockets for vertical installations.
 - 2) Specify for horizontal or vertical installation.
 - 3) No leg sockets provided on horizontal tanks.
- 2 each 2" ASME inspection openings are standard on tanks 36" diameter and below.
12"x16" ASME inspection openings are standard on tanks with 42" diameters and above.

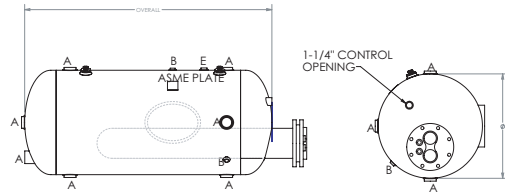

NOTE:

- 1) State Custom Storage Tanks with Heating Coils (Horizontal Configuration)
- 2) Specify for horizontal or vertical installation.
- 3) No leg sockets provided on horizontal tanks.

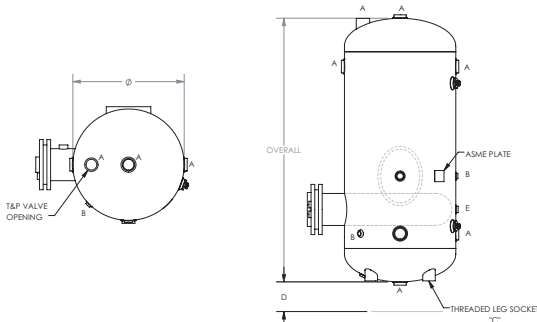

NOTE:
State Custom Storage Tanks with Heating Coils
(Vertical Configuration)

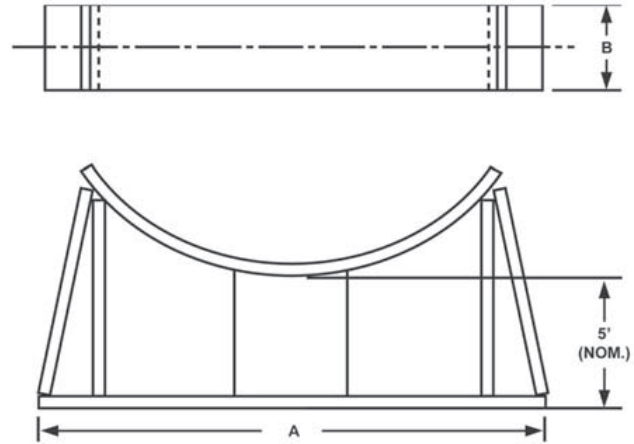

TANK SADDLES

Part No.	Tank Dia.	A	B
P2-2600-20	20	22	6
P2-2600-24	24	26	6
P2-2600-30	30	32	6
P2-2600-36	36	38	6
P2-2600-42	42	44	6
P2-2600-48	48	50	6
P2-2600-54	54	56	8
P2-2600-60	60	62	8
P2-2600-66	66	58	8
P2-2600-72	72	74	10
P2-2600-84	84	86	10

Dimensions in Inches

	A	B	C	D	E
20	2	3/4	1-1/2	6	3/4
24 thru 36	2-1/2	3/4	2-1/2	8	1
42 thru 48	3	3/4	3	10	1
54 thru 96	3	3/4	3	10	1

