

On-Demand Water Heater Installation Manual and Owner's Guide



ANSI Z21.10.3 • CSA 4.3



Model

160X3P
180X3P
199X3P

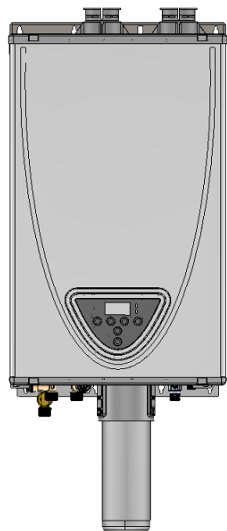

Gas Tankless Water Heater™

Suitable for water (potable) heating only.



WARNING

If the information in these instructions is not followed exactly, a fire or explosion may result causing property damage, personal injury or death.

- Do not store or use gasoline or other flammable vapors and liquids in the vicinity of this or any other appliance.
- **WHAT TO DO IF YOU SMELL GAS**
 - Do not try to light any appliance.
 - Do not touch any electric switch; do not use any phone in your building.
 - Immediately call your gas supplier from a neighbor's phone. Follow the gas supplier's instructions.
 - If you cannot reach your gas supplier, call the fire department.
- Installation and service must be performed by a qualified installer, service agency or the gas supplier.

FEATURING

- INTEGRATED RECIRCULATION PUMP
- ENDLESS HOT WATER
- ON-DEMAND USAGE
- COMPACT, SPACE SAVING
- ENERGY CONSERVATION
- COMPUTERIZED SAFETY
- NO PILOT LIGHT
- Complies with SCAQMD Rule 1146.2 for natural gas NOx emissions of 14 ng/J or 20 ppm.
- EASY-LINK SYSTEM
- X3™ TECHNOLOGY

If you have any questions,
please call or write to

USA: 500 Tennessee Waltz Parkway
Ashland City, TN 37015
1-877-737-2840

CANADA: 599 Hill Street West
Fergus, ON N1M 2X1
1-888-479-8324

Keep this manual near the water heater for future reference whenever maintenance, adjustment or service is required.

CONTENTS

On-Demand Water Heater

Installation Manual and Owner's Guide

SPECIFICATIONS	4	14 Electrical connection	45
DIMENSIONS	5	15 Temperature remote controller	46
SAFETY GUIDELINES	6	Installation	46
SAFETY DEFINITION.....	6	16 High altitude settings	48
INTRODUCTION	7	17 Freeze protection system	49
INSTALLATION	8	18 Easy-Link System	50
1 Read this section before you start	8	Easy link connection procedures	51
2 Familiarize yourself with the components.....	11	GETTING STARTED	52
Included items/Optional items	11	Initial operation	52
3 Installation environment and unit		OPERATING SAFETY	55
clearances.	12	OPERATION	57
4 Mounting the water heater	13	Controller settings	57
5 General instructions of venting.	14	Set outlet water temperature.....	58
How to install venting into the water heater	15	Setting the time	59
DIP switch settings for the vent style	16	Pump operation timers.....	59
6 Combustion air supply	17	Setting pump timers & operation.....	60
Combustion air supply options	20	Selecting a pump timer.....	62
Direct vent air intake moisture protection	21	Display example	63
7 Exhaust vent for Indoor installation	22	On-demand pump operation.....	64
① ABS,PVC,CPVC, or polypropylene vent	22	Information mode.....	65
①-1 Direct Vent installation examples	23	Unit of measure conversion.....	65
①-2 Power Vent installation examples	23	PCB settings	66
①-3 Vent terminations.....	24	Setting the temperature on the PCB	66
8 Clearance	26	MAINTENANCE AND SERVICE	67
Vent termination clearances	26	Regular maintenance.....	67
Clearances for sidewall terminations	27	Measuring inlet gas pressure	67
Clearances for rooftop terminations	28	Water filter cleaning.....	68
9 Outdoor installation	29	Rain protection tray cleaning	69
10 Gas supply and gas pipe sizing	31	How to drain the unit for vacations	
Gas connections	31	or long periods of non-use	69
Natural Gas supply piping.....	32	TROUBLESHOOTING	70
Propane (LP) supply piping.....	32	ERROR CODE.....	71
11 LP gas conversion	33	Single unit installation	71
Gas conversion procedure	33	How error codes display	
Check combustion status.....	35	in an Easy-Link System	72
CO ₂ value.....	35	Fault analysis	73
12 Water connections	36	REPAIR PARTS	76
Recirculation pump modes.....	37	Component diagram.....	76
Standard recirculation	38	Parts list.....	81
Standard non-recirculation.....	38	OUTPUT TEMPERATURE CHART	82
Recirculation with cross over valve	39		
Installation w/o recirculation	41		
X3™ Technology	42		
Pressure relief valve	43		
13 Condensate drain	44		

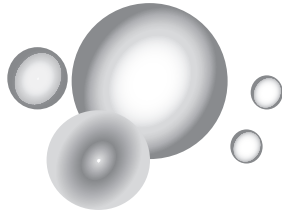

Installation Manual and Owner's Guide

CONGRATULATIONS

Congratulations and thank you for choosing our tankless water heater. Before use, we recommend that you read through this installation manual carefully. Keep this manual for future reference.

If you need an additional manual, contact the manufacturer or your local distributor. You may also download a manual from our website. When you call, please tell us the product name and the serial number of your unit written on the rating plate of the water heater.

SPECIFICATIONS

Model		160X3P (A/JT-H5JP)	180X3P (A/JT-H5SP)	199X3P (A/JT-H5P)	
Natural Gas Input (Operating Range)	BTU/h	Min: 9,000 Max.: 160,000	Min: 9,000 Max.: 180,000	Min: 9,000 Max.: 199,000	
Propane Input (Operating Range)	BTU/h	Min: 9,000 Max.: 160,000	Min: 9,000 Max.: 180,000	Min: 9,000 Max.: 199,000	
Gas Connection		1/2" NPT			
Water Connections		3/4" NPT			
Water Pressure*	psi (MPa)	15 - 150 (0.1 - 1)			
Max. water flow rate	GPM (L/min)	6.5 (25)	8.0 (30)	10.0 (38)	
Natural gas Inlet Pressure	" W.C. (kPa)	Min 3.5 (0.87) Max. 10.5 (2.62)			
Propane Inlet Pressure	" W.C. (kPa)	Min 8.0 (1.99) Max. 13.0 (3.24)			
Weight	lbs. (kg)	68.8 (31.0)			
Dimensions	inch	H 27.4 x W 17.7 x D 11.2			
	mm	H 696 x W 450 x D 285			
Ignition		Electronic Ignition			
Electric	Supply	VAC/Hz	120/60		
	Consumption	Operation	W/pump	126.7/1.55	
			W/O pump	Indoor W/A	113.8/1.41
		Outdoor W/A		107.0/1.30	
	Standby	W/A	1.2/0.04		
	Freeze-Protection	W/A	129.5/1.10		
Water heater Category**		Category IV			
Maximum Pipe length*** (Hot Water supply line and Dedicated Return line)	Pipe Diameter	3/4"	500 ft (152.4 m)		
		1/2"	200 ft (61 m)		

*40 psi or above is recommended for maximum flow.

**Water heater Category - Does not apply to Outdoor or Direct Vent Installations.

Category -IV - a water heater that operates with a positive vent static pressure and with a vent gas temperature that may cause excessive condensate production in the vent.

***Refer to p. 36 for additional information available on pipe lengths.

NOTE:

- Check the rating plate to ensure that this product matches your specifications.
- **The manufacturer reserves the right to discontinue, or change at any time, specifications or designs without notice and without incurring obligation.**

DIMENSIONS

Unit: Inch (mm)

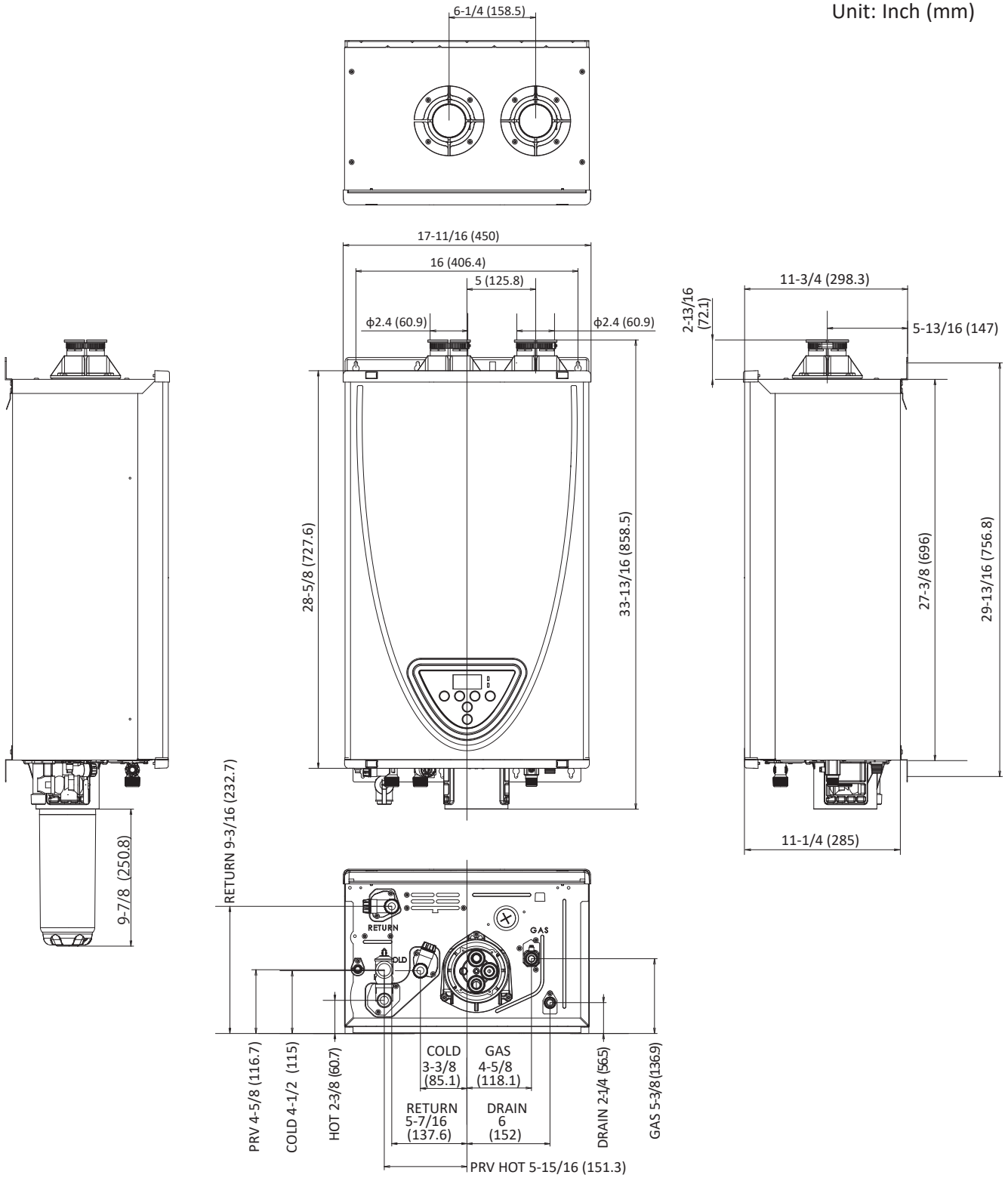

SAFETY GUIDELINES

SAFETY DEFINITION



DANGER

Indicates an imminently hazardous situation which, if not avoided, will result in death or serious injury.



WARNING

Indicates an imminently hazardous situation which, if not avoided, could result in death or serious injury.



CAUTION

Indicates an imminently hazardous situation which, if not avoided, could result in minor or moderate injury.

NOTICE

Indicates information considered important but not hazard related.

1. Follow all local codes, or in the absence of local codes, follow the current edition of the National Fuel Gas Code: ANSI Z223.1/NFPA 54 in the USA or B149.1 Natural Gas, Propane Installation Code in Canada.
2. Properly ground the unit in accordance with all local codes or in the absence of local codes, with the National Electrical Codes: ANSI/NFPA 70 in the USA or CSA standard C22.1 Canadian Electrical Code Part 1 in Canada.
3. Carefully plan where you intend to install the water heater. Please ensure:
 - Your water heater will have enough combustible air and proper ventilation.
 - Locate your heater where water leakage will not damage surrounding areas. (Refer to p. 8.)
4. Check the rating plate for the correct **GAS TYPE, GAS PRESSURE, WATER PRESSURE and ELECTRIC RATING**.
*If this unit does not match your requirements, **do not install and consult with the manufacturer**.
5. If any problem should occur, turn off all hot water taps and turn off the gas. Then call a trained technician or the Gas Company or the manufacturer.
6. **The water heater is set only for Natural gas at the factory. If your gas type is LP Gas, gas conversion shall be required with the included gas conversion kit (100320420) by a qualified installer. (Refer to pp. 11 and 33.)**
7. **The water heater can be installed outdoors with the outdoor installation kit. (Refer to pp. 11 and 29.)**



WARNING

- Water temperatures over 125°F (52°C) can cause severe burns instantly or death from scalding. The water temperature is set at 120°F (50°C) from the factory to minimize any scalding risk. Before bathing or showering, always check the water temperature.
- Do not store or use gasoline or other flammables, vapors, or liquids in the vicinity of this appliance.
- Do not reverse the water and/or gas connections as this will damage the gas valves and can cause severe injury or death. Follow the diagram on pp. 38 and 39 when installing your water heater.
- Should overheating occur or the gas supply fails to shut off, turn off the manual gas control valve to the appliance.
- Do not use this appliance if any part has been in contact with or been immersed in water. Immediately call a qualified installer or service agency to replace a flooded water heater. Do not attempt to repair the unit. It must be replaced.
- Do not disconnect the electrical supply if the ambient temperature will drop below freezing. The Freeze Protection System only works if the unit has electrical power. The warranty will not be covered if the heat exchanger is damaged due to freezing. Refer to the section on the Freeze Protection System on p. 49 for more information.
- Failure to observe these warnings could result in severe personal injury or death.

INTRODUCTION

- This manual provides information necessary for the installation, operation, and maintenance of the water heater. Please read all installation instructions completely before installing this product. If you have any problems or questions regarding the installation, operation, or maintenance, consult the manufacturer or its local representative.
- This is on-demand, tankless water heater is designed to efficiently supply hot water when properly sized and installed.
- This water heater incorporates a recirculation pump. There are 3 operational modes to choose from:

Recirculation with Dedicated Return line, On-Demand mode, and Crossover Valve Mode. See page 36 for additional information.

- These high efficiency models have a built-in secondary heat exchanger that absorbs latent heat from the exhaust gas and uses it to increase the efficiency.
- The rating plate lists the model description and is located on the side of the water heater.
- When the water heater is installed outdoors, attach the vent cap (100320424) from the manufacturer to the appliance. (Refer to pp.11, 29, and 30.) Install outdoors only in areas with mild temperature climate.

TYPICAL OPERATION SEQUENCE

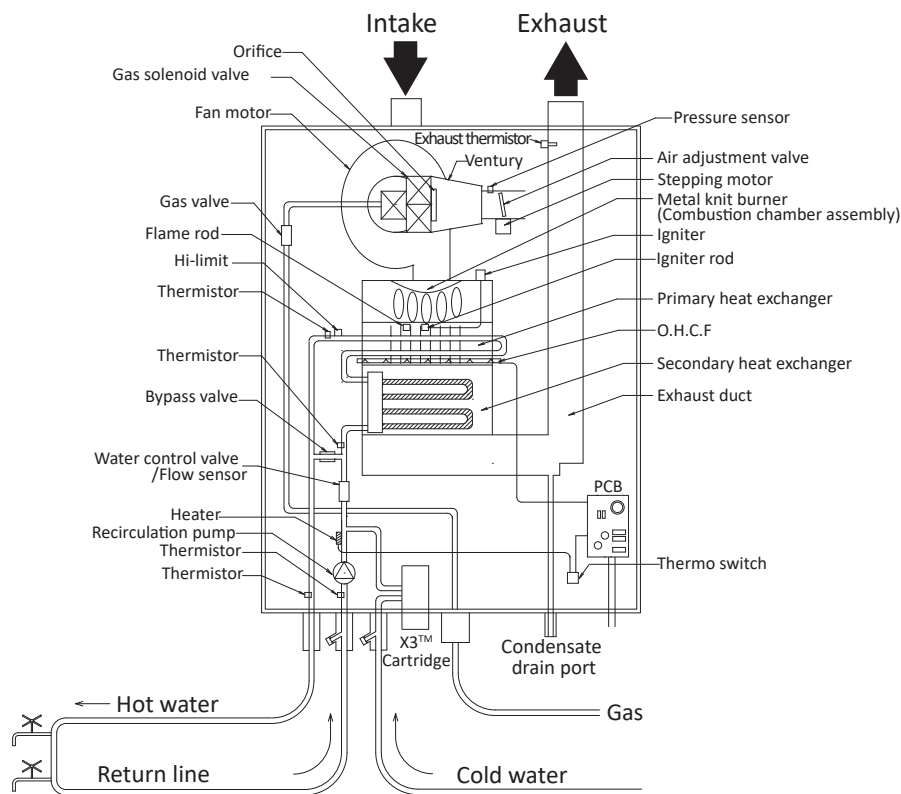

*This diagram illustrates tankless water heater design concepts only and does not accurately represent the water heater's physical description.

1. A hot water tap is turned on. NOTICE: If recirculation with dedicated return line configuration is installed, the recirculation pump activates and the system circulates water within the loop. Then proceeds to step 3.
2. Water treated by the X3™ Cartridge enters the heater.
3. The water flow sensor detects the water flow.
4. The computer initiates the fan motor, opens the gas valve, and sends a signal to the igniter to create an ignition spark.
5. The gas ignites and flames appear within the burner chamber.
6. Water is heated as it circulates through the heat exchangers.
7. Thermistors measure water temperatures throughout the water heater, the control modulates the gas and water valves to ensure proper output water temperature.
8. When the tap is turned off, the unit shuts down.



Step 1: Read this section before you start...



WARNING

- Installation and service must be performed by a qualified installer (for example, a licensed plumber or gas fitter). Otherwise, the warranty will be void.
- The installer (licensed professional) is responsible for the correct installation of the water heater and for compliance with all national, state/provincial, and local codes.
- The manufacturer does not recommend installing the water heater in a pit or location where gas and water can accumulate.
- Do not have the vent terminal pointing toward any operating window, door, or opening into a building.
- Do not install the air intake next to any source of airborne debris, such as a clothes dryer, that can cause debris to be trapped inside the combustion chamber, unless the system is direct-vented.
- Do not install the unit where water, debris, flammable vapors, corrosive or acid forming chemicals may get into the flue terminal or the air intake line.
- **The manufacturer does not recommend installing the water heater in an attic due to safety issues.** If you install the water heater in an attic:
 - Make sure the unit will have enough combustion air and proper ventilation. Failure to do so could lead to carbon monoxide poisoning or death.
 - Keep the area around the water heater clean. When dust collects on the flame sensor and pressure sensor, the water heater will shut down on an error code.
 - Place the unit where it will allow easy access for service and maintenance.
 - A drain pan, or other means of protection against water damage, is recommended to be installed under the water heater in case of leaks. See the NOTICE below.
- **The water heater must be securely mounted to a wall or other suitable structure.**
- **Failure to observe these warnings could result in severe personal injury, death, and/or property damage.**

NOTICE

- **The warranty will not cover damage caused by water quality.**
 - Only potable water can be used with this water heater. Do not introduce pool or spa water, or any chemically treated water into the water heater.
 - Introduction of water with iron greater than 0.3 mg/L.
 - Water pH levels must be between 6.5 and 8.5.
 - Well water must be treated.
- **The manufacturer recommends direct venting when the water heater is installed in beauty salons, dry cleaners or any other locations in which such chemicals are present in the air.** Some chemicals used in beauty salons or dry cleaners may affect the flame sensor. In such cases, the water heater may not work properly.
- Although the water heater is designed to operate with minimal sound, **the manufacturer does not recommend installing the unit on a wall adjacent to a bedroom, or a room that is intended for quiet study or meditation, etc.**
- Locate your water heater close to a drain where water leakage will not do damage to surrounding areas. As with any water heating appliance, the potential for leakage at some time in the life of the product does exist. A drain pan, or other means of protection against water damage, is recommended to be installed under the water heater in case of leaks. In addition, you may install an active water leak detector with a shutoff valve which can turn off the water supply in the event of a leak. The manufacturer is not responsible for damage due to water leaks. If you install a drain pan under the unit, ensure that it will not restrict the combustion air flow.
- This water heater is not suitable for combination water (potable) heating and space heating applications.



- **▲ WARNING!**
 - Follow all local codes, or in the absence of local codes, follow the current edition of the National Fuel Gas Code: ANSI Z223.1/NFPA 54 in the USA or B149.1 Natural Gas, Propane Installation Code in Canada.
 - Follow the electrical code requirements of the local authority having jurisdiction. In the absence of such requirements, follow the current edition of the National Electrical Code ANSI/NFPA 70 in the U.S. or the current edition of CSA C22.1 Canadian Electrical Code Part 1 in Canada.
 - Failure to do so could result in death, personal injury, and/or property damage.
- All gas water heaters require correct installation to ensure safe and efficient operation. This manual must be followed exactly. Read the "Safety Guidelines" Section.
- The water heater shall be securely wall-mounted or mounted on a stand, or installed in the approved recess box.
- For outdoor installations, locate the water heater in an open, un-roofed area. Maintain 3 in. (76 mm) minimum clearance from the left and right sides of the unit. See "Clearances" on p.12.
- The length of piping between the water heater and fixture determines the time it takes for the hot water to arrive. Consider installing the water heater closer to the fixtures, if the plumbing system allows for it. The water heater should be the first appliance to access the water line after utilities water meter.
- Install the water heater in a heated area where below freezing temperature cannot occur. Units installed in areas subject to below freezing temperature MUST follow the steps outlined on p. 49. The warranty does not cover damage caused by freezing.
- Maintain proper space for servicing. Install the unit so that it can be connected or removed easily. Refer to the "Unit clearances" section for proper clearances.
- Carefully plan the installation location of the heater and vent terminations. Contaminants such as aerosols, lint, and fine powders (including flour) can clog the air intake and reduce the operation of the fan. This, in turn, can cause improper combustion and reduce the life of the water heater. Regularly ensure that the area around the water heater, vent termination, and air intake is free of dust, debris, and other contaminants. In environments with a high level of contaminants (laundry facilities, hair salons, pet salons, chemical plants, commercial kitchens, etc.), direct venting is required.
- The water heater must be installed where the proper amount of combustion air will be available to it at all times without obstructions. When installed indoors, the water heater can be direct vented.
- Do not install the unit where the exhaust vent is pointing into any opening in a building or where the noise may disturb your neighbors. Make sure the vent termination meets the required clearance from any doorway or opening to prevent exhaust from entering a building. (Refer to pp. 10, 26 and 27.) Check local code requirements prior to installation.
- These units are equipped with a thermistor in the exhaust system. This component prevents heat damage to ABS, PVC, CPVC, or polypropylene (Plastic) venting when it is used. If the exhaust gas temperature exceeds 140°F (60 °C), this component will enable the unit to safely stop operations.
- If the water heater is used as a direct-vent appliance, the unit requires 2 in. or 3 in. combustion air supply pipe. The intake pipe must be sealed airtight. Refer to pp. 14 to 16, and pp. 21 to 24 for more detail.
- Terminating the venting through a sidewall is recommended for the direct-vent system.
- Running the exhaust vent and the intake pipe parallel is recommended.
- Terminating the exhaust and intake on the same wall/surface is recommended. Terminating in the same pressure zone allows for pressure balancing, which prevents nuisance shutdowns.
- The manifold gas pressure is preset at factory and is computer controlled. The pressure should not need adjustment.
- Electrical service to the water heater requires a means of disconnection. This will allow power to the water heater to be shut off for servicing and safety purposes.

INSTALLATION

Step 1:



Read this section before you start...

Do not install the heater where water, debris or flammable vapors may get into the flue terminal. This may cause damage to the heater and void the warranty.



Prohibited



Do not have the vent terminal pointing toward any opening into a building. Do not locate your heater in a pit or location where gas and water can accumulate.



Prohibited

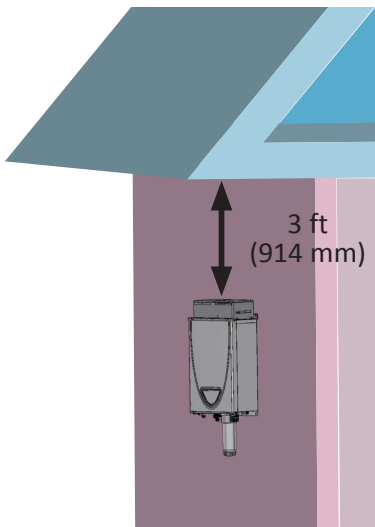

Do not install the exhaust vent for indoor and outdoor models within 3 ft. (914 mm) of an overhang. See the graphic. The area under an overhang must be open to three sides.

Ensure that you meet the minimum clearances shown below for a direct vent termination:

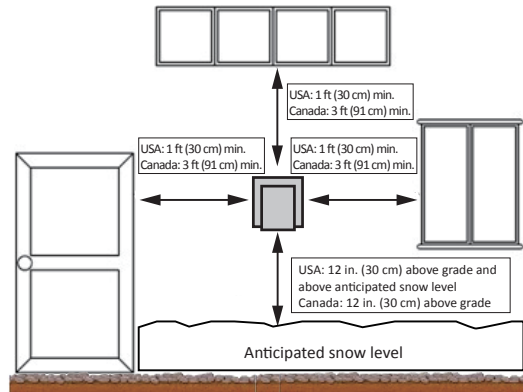

INSTALLATION

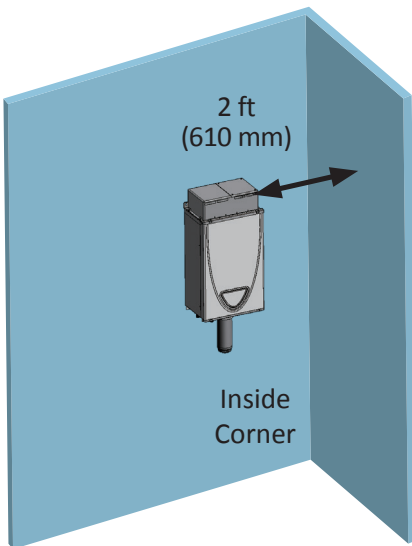

Vent termination must be at least 2 ft (610 mm) away from an inside corner for both outdoor installation and direct-vent installation.

Do not install next to a dryer or any source of airborne debris that can be trapped inside the combustion chamber, unless the system is direct-vented. When direct vented, do not install the air intake near the dryer vent or any source of airborne debris.



INSTALLATION







Step 2:



Familiarize yourself with the components.

Step 2: Familiarize yourself with the components.

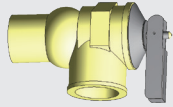
Included items

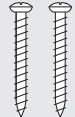
Manual	Communication cable	X3™ cartridge	LP gas conversion kit	Pressure relief valve	Wall mounting bracket	Screws for vent ports
						 Qty: 2

Optional items

No.	Model	Indoor	Outdoor
1.	Temperature remote controller	√	√
2.	Pipe cover	√	√
3.	Neutralizer kit	√	√
4.	Recess box		√
5.	Outdoor vent cap		√

- Temperature remote controller**
 100276687 (TM-RE43); Qty:1 See p.42.
- Pipe cover**
 100320428 (TH-PC05)
 The pipe cover protects the piping and X3™ Technology from environmental factors such as rain, UV rays and improves the appearance of the installation. The pipe cover or recess box is recommended when the water heater is installed outside.
- Neutralizer kit**
 100112159 (TH-NT01)
 Used to raise the pH of the condensate to allow for safe drainage. (Refer to the Condensate Drain section for more information.)
- Recess box**
 New construction: 100321565
 Retrofit: 100321749
 Recesses the water heater when installed outdoors. The recess box or pipe cover is recommended when the water heater is installed outdoors.
- Outdoor vent cap**
 100320424 (TH-VC05)
 The outdoor installation kit consists of a vent top, panel cover, and junction box. This kit **MUST** be used when the water heater is installed outdoors, unless the water heater is installed in a recess box.

Step 3: Installation environment and unit clearances

Installation environment

▲ Warning! Do not store or use flammable materials, vapors, or liquids in the same location where this water heater is installed.

Before installing the water heater, ensure that it will be located as described on p. 8 through 10. In addition to that, the following factors shall be taken into account for the installation location and method. Refer to each section in the installation manual.

Atmosphere temperature

Install the water heater in a heated area where below freezing temperature cannot occur. Units installed in areas subject to below freezing temperature MUST follow the steps outlined on p. 49. The pipe cover or recess box is recommended when the water heater is installed outdoors because it provides better protection from the elements.

Combustion air supply

The water heater requires fresh combustion air should be free of corrosive elements and flammable vapors. If it is installed at the contaminated area or in a confined area, direct venting installation is recommended. (Refer to pp. 17 to 25.)

Proper ventilation

For proper operation the water heater must be vented in accordance with the section "Venting of Equipment" of the current edition of the National Fuel Gas Code: ANSI Z223.1/ NFPA 54 in the United States and/or Section 8 of the B149.1 Natural Gas and Propane Installation Code in Canada, as well as applicable local building codes. (Refer to pp. 14 to 30.)

Proper mounting and clearance

The water heater shall be securely mounted on wall that can support the weight of the water heater. A wall mounting bracket is supplied with the water heater to securely mount the water heater to wall studs. (Refer to p. 13.) The water lines, gas line, condensate drain line, and pressure relief valve discharge line shall be supported using field supplied pipe hangers. The water heater shall not bear the weight of these lines. The water heater requires proper installation clearance for operation and service as described in the right.

Condensate Drain line

The condensate produced is acidic. Drain the condensate in accordance with all local codes and common safety practices. (Refer to p. 44.)

Unit clearances

▲ Warning! Maintain all clearances around the water heater. Failure to do so could create a fire hazard, potentially leading to death, serious injury, and/or property damage.

Indoor

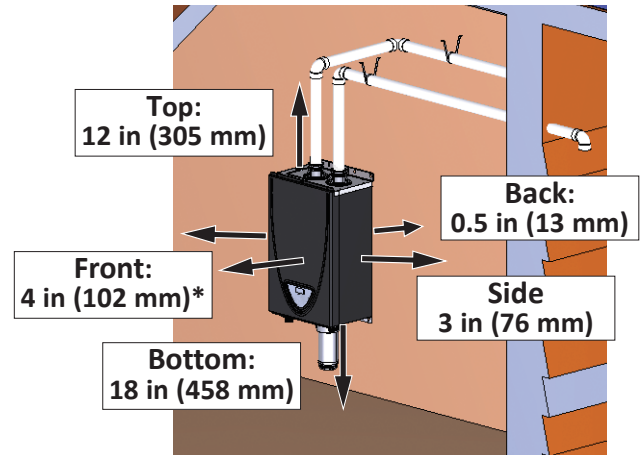

*24 inches (610 mm) recommended for maintenance.

Outdoor

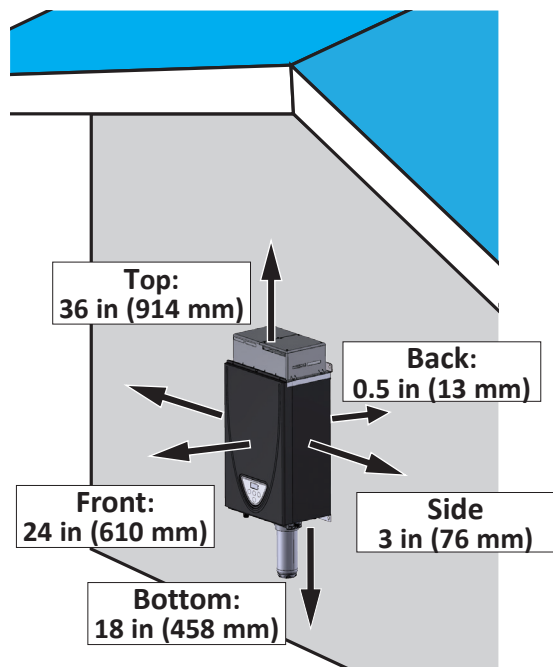

Step 4: Mounting the water heater

1. Secure the wall mounting bracket with 4 screws to the wall studs. Make sure to level the bracket.

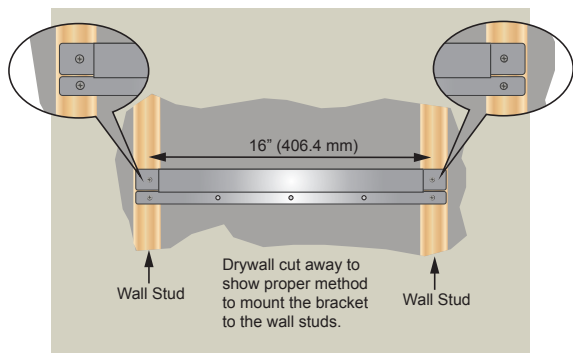

2. Hang the water heater bracket on the wall bracket.

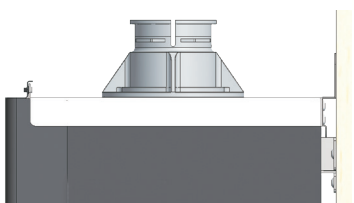
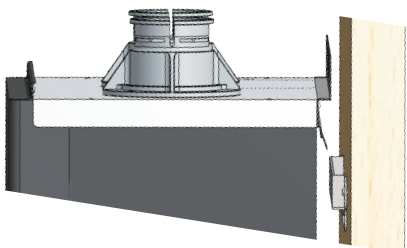
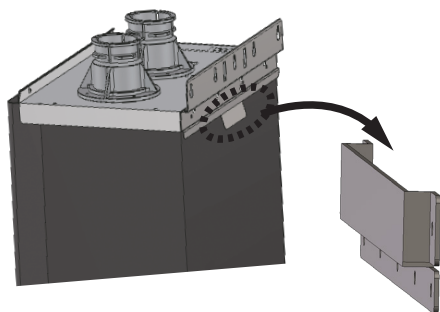

3. Secure the water heater firmly fastening appropriate screws into the upper bracket/bottom brackets of the water heater and wall.

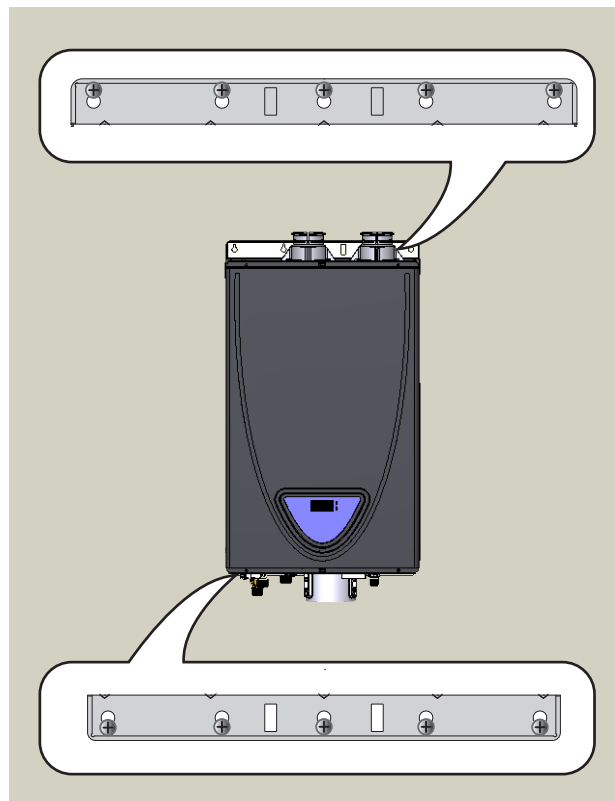

Step 5: General instructions of venting



WARNING

- Improper venting of this appliance can result in excessive levels of carbon monoxide which can result in severe personal injury or death.
- Improper installation can cause nausea or asphyxiation, severe injury or death from carbon monoxide and flue gases poisoning. Improper installation will void product warranty.
- When installing the vent system, all applicable national and local codes must be followed. If you install thimbles, fire stops or other protective devices and they penetrate any combustible or noncombustible construction, be sure to follow all applicable national and local codes.

The Indoor model must be vented in accordance with the section “Venting of Equipment” of the current edition of the National Fuel Gas Code: ANSI Z223.1/NFPA 54 in the United States and/or Section 8 of the B149.1 Natural Gas and Propane Installation Code in Canada, as well as applicable local building codes.

The use of venting materials approved for Category III/IV appliances is recommended whenever possible. However, the Indoor model may also be vented with plastic pipe materials such as ABS, PVC (solid core), CPVC (solid core), or polypropylene. **For details, please refer to the Exhaust Vent (ABS, PVC, CPVC, or Polypropylene Vent) Section on p. 20.** Vent installations in Canada which utilize plastic vent systems must use venting that complies with ULC S636.

General rules for venting water heaters:

- Place the water heater as close as possible to the vent termination.
- The vent collar of the water heater must be fastened directly to an unobstructed vent pipe.
- Do not weld, glue, or permanently bond the vent pipe to the water heater's vent collar.
- Do not cut or alter the vent collar of the unit.
- The vent must be easily removable from the top of the water heater for normal service and inspection of the unit.
- The water heater vent must not be connected to any other gas appliance or vent stack.
- Air supply pipe can be made of ABS, PVC (solid core), CPVC (solid core), polypropylene, or Category III/IV stainless steel. Regarding exhaust pipe, refer to pp. 22 to 24.
- Use of cellular core PVC (ASTM F891), cellular core CPVC, or Radel® (polyphenylsulfone) in nonmetallic venting systems is prohibited. Covering non-metallic vent pipe and fittings with thermal insulation is prohibited.
- Sidewall venting is recommended for the Indoor model. Vertical venting (roof termination) is acceptable.
- The manufacturer recommends running the exhaust vent and the intake pipe as parallel as possible.
- For rooftop venting, a rain cap or other form of termination that prevents rain water from entering into the water heater must be installed.
- Do not terminate vent into a chimney. If the vent must go through the chimney, the vent must run all the way through the chimney with approved vent pipe.
- The water heater shall not be connected to a chimney flue serving a separate appliance, designed to burn solid fuel.

General rules for vent terminations:

- Avoid locating the water heater vent termination near **any air intake devices**. These fans can pick up the exhaust flue products from the water heater and return them to the building. This can create a health hazard.
- Locate the vent termination so that it cannot be blocked by any debris, at any time. Most codes require that the termination be at least 12 in (305 mm) above grade and anticipated snow level, but the installer may determine if it should be higher depending on the job site condition and applicable codes.
- A proper sidewall termination is recommended when the water heater is vented through a sidewall.
- Regarding the clearances from the exhaust termination to the air inlet or opening, refer to pp. 26 to 28.

How to install venting into the water heater



WARNING

- When inserting the pipe into the exhaust/intake port, make sure that the pipe end is cut straight and positioned properly under the o-ring to seal the connection firmly.
- Improper venting of this appliance can result in excessive levels of carbon monoxide which can result in severe personal injury or death.
- Improper installation can cause nausea or asphyxiation, severe injury or death from carbon monoxide and flue gases poisoning. Improper installation will void product warranty.

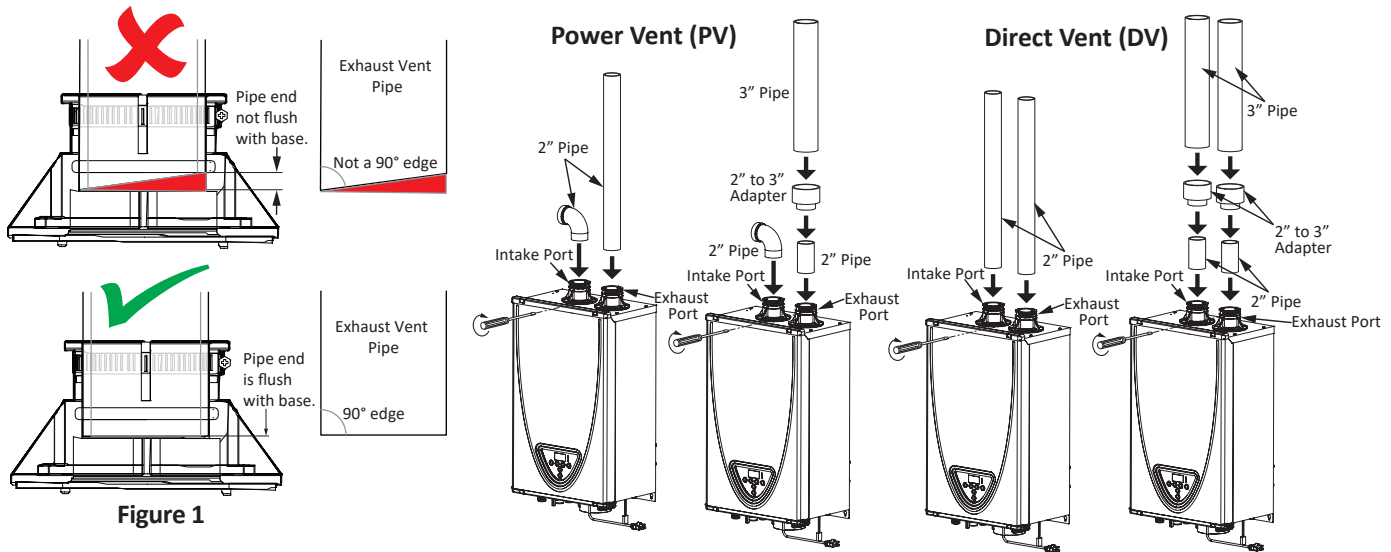

Figure 1

1. Insert 2" straight pipe fully into the exhaust/intake ports. (Figure 1) The pipes should insert 2 inches.
 ▲ **WARNING:** The exhaust vent pipe connection to the water heater must be flush to maintain a proper seal. Check pipe for a 90° edge before installation. DO NOT use a field cut end for the connection. Failure to follow can cause carbon monoxide poisoning or death.
2. Use a screwdriver to tighten the clamp. (Figure 2)
3. Use the supplied self-tapping screws to secure the venting to the intake and exhaust ports as shown in the image on the right. (Figure 3)

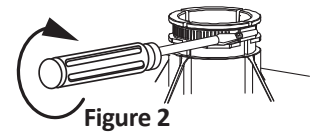

Figure 2

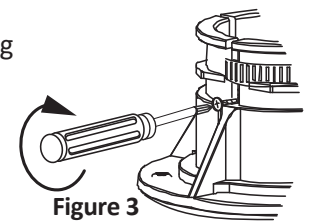

Figure 3

For 3" Vent Installs: Insert 2" straight pipe, up to 1 ft max. length, into the heater exhaust/intake ports.

▲ **WARNING:** The exhaust vent pipe connection to the water heater must be flush to maintain a proper seal. Check pipe for a 90° edge before installation. DO NOT use a field cut end for the connection. Failure to follow can cause carbon monoxide poisoning or death.

Install a 2" x 3" increaser to convert to 3" venting. For low clearance installations, a 2" long sweep elbow may be used. Then 1 ft max length straight pipe may be used to fit a 2" x 3" increaser.

Air Intake for Power Vent Installs: Insert the male end of a 2" or 3" long sweep street elbow into the heater's air intake port.



DIP switch settings for the vent style

Set the DIP switch as shown in the following for your vent style. If your vent style is out of the range of the upper table, change the DIP switches as shown in the lower table. **▲ WARNING!** Before changing the DIP switches, make sure that there is no power supply, gas supply, and water supply.

Changing DIP switch

1. Remove the front cover.
2. Pull out the PCB.
3. Locate the lower bank of the DIP switches.
4. Change the DIP switch.

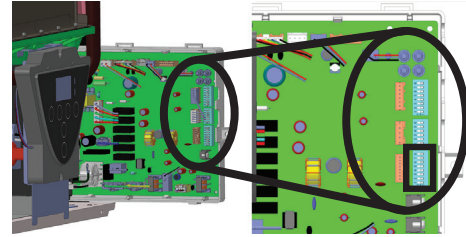

DIP switches (Default)		Vent style	Vent type	Vent length
Lower bank of DIP switches	 No. 3: ON No. 4: OFF	2" DV	Intake	10 to 60 ft (3.1 to 18.3 m)
			Exhaust	
		2" PV	Intake	2" elbow: 5 ft (1.5 m)
			Exhaust	15 to 60 ft (4.6 to 18.3 m)
		3" DV	Intake	60 to 150 ft (18.3 to 45.7 m)
			Exhaust	
		3" PV	Intake	2" elbow: 5 ft (1.5 m)
			Exhaust	60 to 150 ft (18.3 to 45.7 m)

DIP switches		Vent style	Vent type	Vent length
Lower bank of DIP switches	 No. 3: OFF No. 4: ON	2" DV	Intake	5 to 9.9 ft (1.5 to 3.0 m)
			Exhaust	
		2" PV	Intake	2" elbow: 5 ft (1.5 m)
			Exhaust	5 to 14.9 ft (1.5 to 4.5 m)
		3" DV	Intake	5 to 59.9 ft (1.5 to 18.3 m)
			Exhaust	
		3" PV	Intake	2" elbow: 5 ft (1.5 m)
			Exhaust	5 to 59.9 ft (1.5 to 18.3 m)
Outdoor installation (Refer to p.29.)				

Step 6: Combustion air supply



WARNING

This gas water heater requires an adequate source of clean air for combustion and ventilation. Without sufficient air, your water heater may not operate properly and may emit excessive and abnormal amounts of carbon monoxide which may result in carbon monoxide poisoning or death.

NOTICE

- **The guidelines in this section apply to installations within the United States. All U.S. installations must conform to the National Fuel Gas Code, ANSI Z223.1/NFPA 54 (current edition) and local codes.**
- **Canadian requirements differ from the guidelines in this section. In Canada, follow the requirements of B149.1 (Natural Gas and Propane Installation Code, current edition) as well as local and provincial codes. Contact your local code enforcement agency for direction.**

Before installing the water heater, you must determine the amount of air needed to supply this water heater and any other gas appliances in the same area and provide adequate air for combustion and ventilation. Consult a qualified person if you're unsure of the proper way to supply air to your water heater.

Check for Chemicals:

Air for combustion and ventilation must be clean and free of corrosive chemicals. If corrosive chemicals, such as sulfur, flourine, or chlorine are present, the water heater must be direct vented. Failure due to these corrosive chemicals is not covered by the warranty.

WARNING!

In all cases, ensure that corrosive chemicals are not present at the air intake. Presence of such chemicals at the air intake could result in death, personal injury, or property damage. Examples of locations that require outside air due to chemicals include:

- Beauty salons
- Photo processing labs
- Indoor pools
- Laundry, hobby, or craft rooms
- Chemical storage areas

Products such as aerosol sprays, detergents, bleaches, cleaning solvents, gasoline, air fresheners, paint and varnish removers, and refrigerants should not be stored or used near the water heater.

Does your installation space have sufficient combustion air?

Ventilation with outside air is recommended for all installations. Even if the water heater is installed in a large, open room inside the house, outdoor air is usually needed because modern homes are very tightly sealed and often do not supply enough air to the water heater. However, when installed in a large indoor space, it may be possible to provide enough air without outside ventilation. If you are unsure if your installation location has enough ventilation, contact your local gas utility company or code officials for a safety inspection or direct vent the water heater. The following instructions will help determine if it may be possible to install the water heater without outside ventilation.

Calculate total BTU/h rating of all appliances.

To calculate the combustion air and ventilation required, add up the total BTU/h ratings of all gas burning appliances (e.g., water heaters, furnaces, clothes dryers) in the same area. Do not include appliances that are direct vented. Refer to the following example.

Your water heater’s BTU/h rating is on the rating plate. The BTU/h ratings should be on the other appliances’ rating plates. If you have trouble determining the BTU/h ratings, contact the manufacturer or have a qualified person determine the ventilation requirements.

NOTICE: If you are replacing your old water heater with one that has a higher BTU/h rating, the amount of ventilation required may be greater.

Example:

Gas Burning Appliance	BTU/h Rating
Gas Water Heater	199,000
Furnace	75,000
Dryer	20,000
Total	294,000

Your appliances:

Gas Burning Appliance	BTU/h Rating
Gas Water Heater	
Total	

Calculate the air volume of the room

Air requirements depend on the size of the room.

$$\text{Room Volume (ft}^3\text{)} = \text{Floor Area (ft}^2\text{)} \times \text{Ceiling Height (ft)}$$

If there are large objects in the room (e.g., refrigerator, furnace, car), subtract their volume from the volume of the room to get a better estimate of the air available.

$$\text{Air Volume} = \text{Room Volume} - \text{Object Volume}$$

NOTE: Adjoining rooms with permanently opened doorways can be counted as part of the calculation.

Calculate required air volume

A water heater installed in an unconfined attic, garage, or space requires that the space be at least 50 ft³ (1.42 m³) per 1,000 BTU/h of the total input for all gas burning appliances in the same area.

$$\text{Required Air Volume (ft}^3\text{)} = \text{Total Appliance Energy Rating (btu/h)} \times 50 \text{ ft}^3 / 1000 \text{ (btu/h)}$$

Example:

$$(294,000 \times 50) / 1000 = 14,700 \text{ ft}^3$$

If the air volume of the room is less than the required air volume, you must direct vent the water heater or provide permanent outside air openings that draw in sufficient air. Go to “Install with outside ventilation” if you want to provide combustion air with outside ventilation.

If the air volume of the room is greater than the required air volume, it may be possible to install the water heater without outside ventilation. However, be sure to consider the effects of exhaust fans.

Exhaust fans can affect the amount of combustion air that is available in your home. Appliances such as furnaces, whole house fans, and clothes dryers draw air out of your home. If they draw air out faster than it can be replaced, your water heater may not have enough oxygen to fire properly. Back-drafting may also result, which is when negative air pressure pulls air backwards through chimneys or appliance vents. These events can cause unsatisfactory water heater performance. The best solution is to direct vent the water heater or install an adequate number of make-up air vents. (See “Install with outside ventilation”.) For more information, consult a qualified technician or your local gas utility.

Install with outside ventilation

Ventilation with outside air is recommended, and, for most installations, is needed. There may be existing ventilation that is adequate, or you may need to add more ventilation.

Supplying outside air to the water heater typically requires two openings. One opening must be within 12 in (305 mm) from the floor and the second opening must be within 12 in (305 mm) from the ceiling. Although a single opening is not preferred, you may use a single opening to outside air if the minimum free area is sized according to Table 1. Two openings must be used when ventilating with air from another room.

The outside air can be taken from a crawl space or attic open to the outdoors and adequately ventilated. You may use vertical or horizontal ducts.

Determine type of ventilation

There are several types of ventilation that can be used. The various options are listed below. See also the illustrations on the next page.

1. Direct to outdoors (See Figures 1&2)
2. Vertical ducts (See Figure 3)
3. Horizontal ducts (See Figure 4)
4. Single opening (not recommended; must be at least 100 in² (645 cm²) . Not appropriate for confined spaces smaller than 50 ft³ (1.42 m³) per 1,000 BTU/h or when getting air from another room.) See Figure 5.
5. From a larger room inside the house (not recommended – refer to "Calculate the air volume of the room" on page 18 to determine if the combined volume of the rooms may be adequate).

Determine minimum free area required for each vent opening

The size of the vent openings depends on the total BTU/h rating of all appliances in the space (use your calculation from “Before beginning”) and the type of vent used. Table 1 provides the minimum free area for each vent opening depending on the type of ventilation.

Calculate minimum size of vent openings and ducts

The vent cross-sectional area needed to provide the free area depends on the covering on the vent openings. Typical vents use louvers or grilles to protect the opening. The louver or grill itself blocks some of the free area, so the opening may need to be larger to meet the minimum free area requirements.

Use the following formula to calculate the required cross-sectional area:

Cross-sectional area = minimum free area required ÷ percent free area of covering (in decimals – e.g., 60 % = 0.6)

For example, an installation area that requires openings with 100 in² (645 cm²) of free area would need 134 in² (865 cm²) openings if using metal louvers rated at 75% free area (100 in² ÷ 0.75 = 134 in²).

If you do not know the % free area for your louver or grill, use the following values:

- For wood louvers or grilles: 25%
- For metal louvers or grilles: 75%

Follow these rules to ensure that vents and ducts provide adequate air flow:

- Each vent opening must be no smaller than 100 in² (645 cm²).
- Ducts must have the same cross-sectional area as free area of the opening.
- Rectangular ducts must have a minimum dimension of no less than 3 in (76 mm).
- All screens must have mesh ¼” or larger.
- Moveable louvers must be locked open or interconnected with the equipment so that they open automatically during operation.
- Keep louvers and grilles clean and free of debris or other obstructions.

Check that air source is clean and free of chemicals

Air for combustion and ventilation must be clean and free of corrosive or flammable chemicals. A failure due to corrosive chemicals in the air is not covered by the warranty. Combustion air must be free of acid-forming chemicals such as sulfur, fluorine, and chlorine. Be sure that air at the vent inlets is free of such chemicals.

Opening Source	Minimum Free Area
Direct to outdoors*	1 in ² (6.5 cm ²) per 4,000 BTU/hr (see Figure 1, 2)
Vertical ducts	1 in ² (6.5 cm ²) per 4,000 BTU/hr (see Figure 3)
Horizontal ducts	1 in ² (6.5 cm ²) per 2,000 BTU/hr (see Figure 4)
Single Opening	1 in ² (6.5 cm ²) per 3,000 BTU/hr (see Figure 5)
Two permanent openings to another room**	1 in ² (6.5 cm ²) per 1,000 Btu/hr (see Figure 6) Opening: 100 in ² (645 cm ²) Min Minimum dimension of air openings: no less than 3 in (76 mm)

*These openings connect directly with the outdoors through a ventilated attic, a ventilated crawl space, or through an outside wall.
**United States: For direction on combining spaces in different stories within the structure, refer to the current edition of the National Fuel Gas Code ANSI Z223.1/NFPA 54. In Canada, contact your local code enforcement agency for direction.

See graphics on next page.

Combustion air supply options

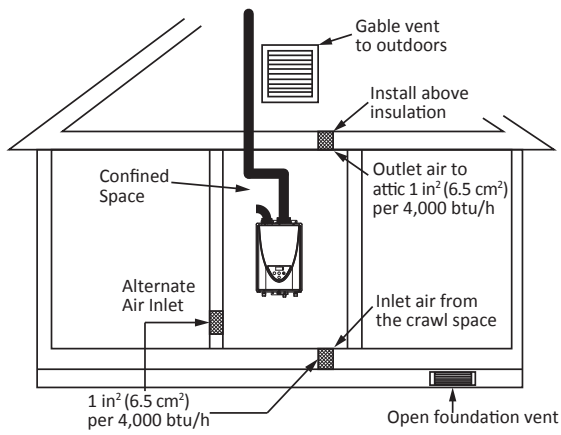

Figure 1 - Direct to outdoors openings

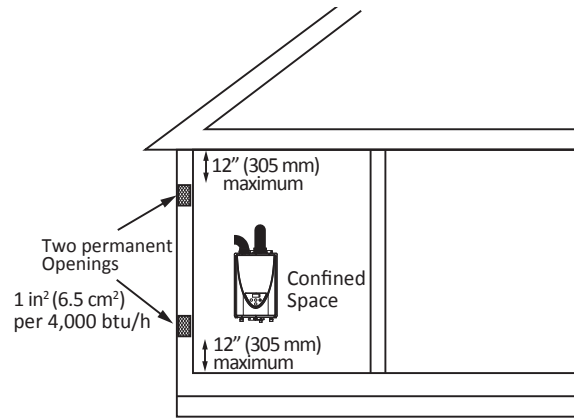

Figure 2 - Direct to outdoors openings
Two permanent openings

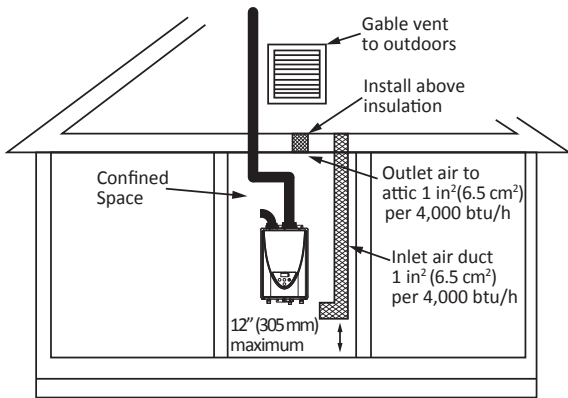

Figure 3 - Vertical duct openings

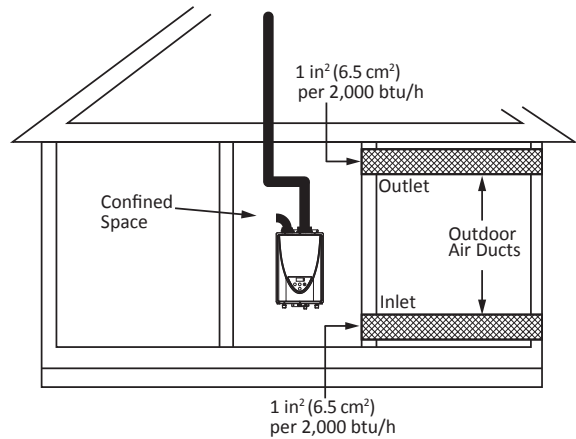

Figure 4 - Horizontal duct openings

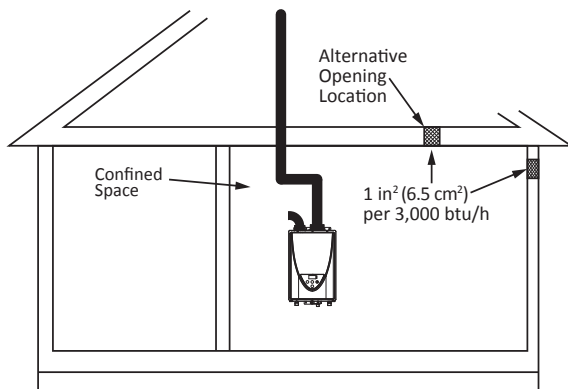

Figure 5 - Single opening

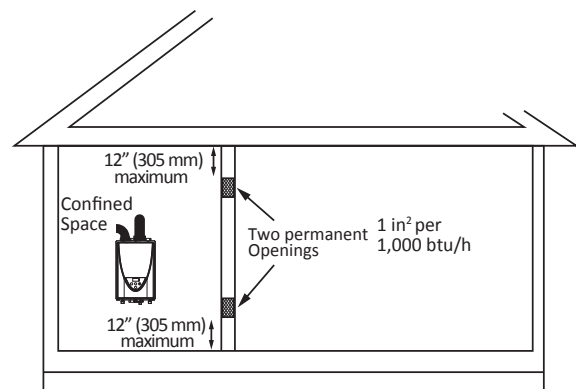

Figure 6 - Two permanent openings

Direct vent air intake moisture protection

The air intake piping in a direct vent system will normally not have any moisture accumulation in it. However, in certain cases, moisture may build up and needs to be drained. Typical situations include, but are not limited to:

- Cold outdoor temperature, particularly if the air inlet is short.
- Air inlet pipe has vertical rise near the heater.
- High outdoor humidity

For installations with any of these conditions, it is recommended that a moisture drain with a trap that flows to a waste drain be installed. See Figures 7 and 8. Install a drain tee assembly and a trap in the inlet vent as close to the water heater as possible. This is to drain any water that may be in the combustion air pipe and prevent it from entering the water heater. The drain tubing in any installation should have a loop trap and flow to an appropriate waste drain. The air intake drain line must be entirely separate from the exhaust vent outlet condensate line. Damage to the water heater due to air intake moisture without following these instructions is not covered by warranty.

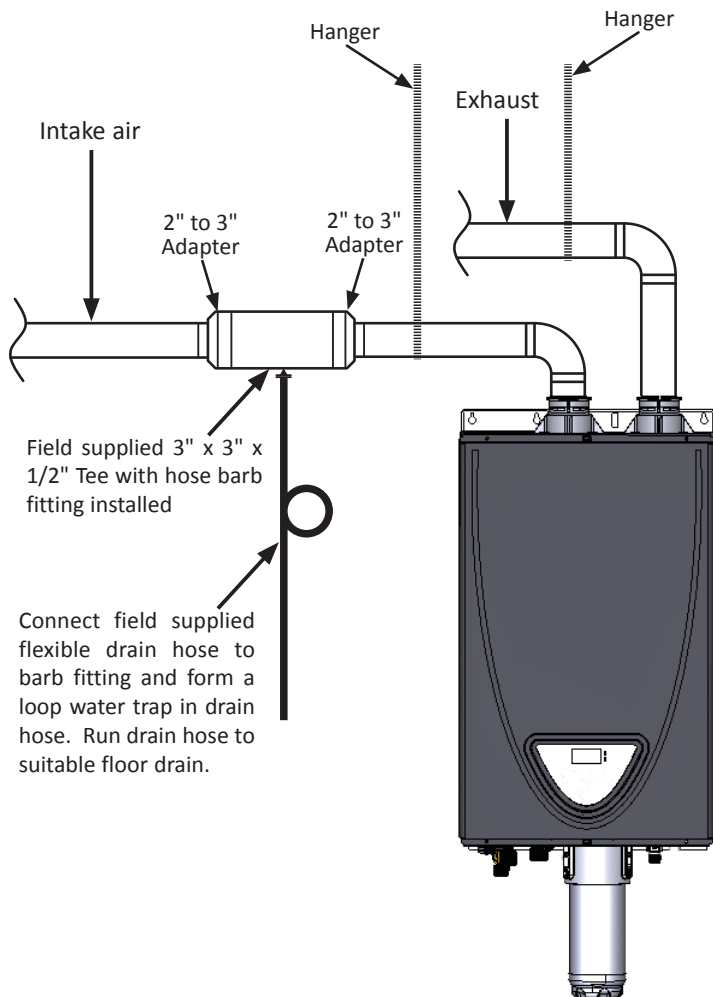

Figure 7

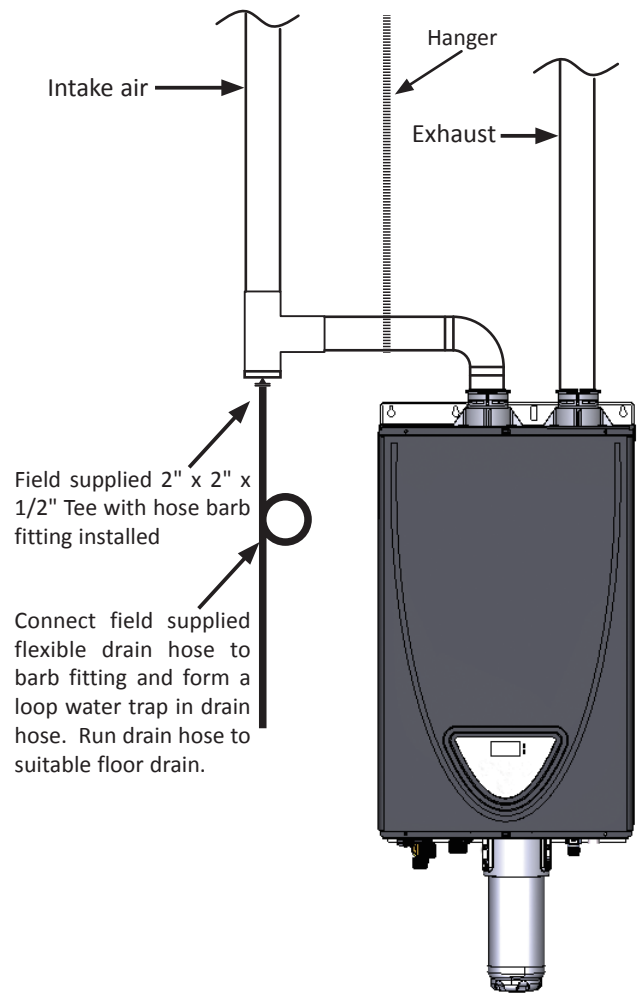

Figure 8



Step 7: Exhaust vent for indoor installation

1 ABS, PVC, CPVC or polypropylene vent

The Indoor model can be vented with ABS, PVC, CPVC, or polypropylene (temperature rated up to 149°F). In Canada, plastic venting must be certified to ULC S636 standards.

- The maximum length of exhaust vent piping must not exceed 60 ft (18.3 m) for 2" venting or 150 ft (45.7 m) for 3" venting. The minimum venting length is one street 90° with a sidewall vent termination
- Do not use more than 5 elbows in a vent system. A 2" elbow and 3" elbow are equivalent to a vent length of 5 ft (1.5 m). If an elbow(s) is used in the vent system, deduct each equivalent length from the Max. vent length to decide the total vent length.
- When the horizontal vent run exceeds 5 ft (1.5 m), support the vent run at 3 ft (0.9 m) intervals with overhead hangers.
- In areas of high rainfall the installation of the rain trap may be necessary.
- Slope horizontal venting sections 1/4" upwards for every 12" (300 mm) toward the termination or according to local and state codes, or in the absence of local or state codes, the current edition of the National Fuel Gas Code, ANSI Z223.1 (NFPA 54).

Item	Material	United States	Canada
Exhaust pipe and Fittings	Schedule 40 PVC	ANSI/ASTM D1785	ULC S636 Certified Materials Only
	PVC-DWV	ANSI/ASTM D2665	
	Schedule 40 CPVC	ANSI/ASTM F441	
	Schedule 40 ABS-DWV	ANSI/ASTM D2661	
	Polypropylene	UL-1738	
Pipe Cement/Primer	PVC	ANSI/ASTM D2564	ULC S636 Certified Materials Only
	CPVC	ANSI/ASTM F493	
	ABS	ANSI/ASTM D2235	

Use of cellular core PVC (ASTM F891), cellular core CPVC, or Radel® (polyphenylsulfone) in non-metallic venting systems is prohibited.

Covering non-metallic vent pipe and fittings with thermal insulation is prohibited.

Approved vent and air intake Polypropylene vent materials: Centrotherm InnoFlue® Single Wall Vent System

No. of Elbows	Max. Vertical or Horizontal (Total) Vent Length	
	2" venting	3" venting
	0 to 10,100 ft (0 to 3,078 m)	0 to 10,100 ft (0 to 3,078 m)
0	60 ft (18.3 m)	150 ft (45.7 m)
1	55 ft (16.8 m)	145 ft (44.2 m)
2	50 ft (15.2 m)	140 ft (42.7 m)
3	45 ft (13.7 m)	135 ft (41.1 m)
4	40 ft (12.2 m)	130 ft (39.6 m)
5	35 ft (10.7 m)	125 ft (38.1 m)

Excludes vent terminators, termination elbows, or rain caps.

For details on the vent connection, refer to pp. 15, 23 to 24.

For each elbow added, deduct 5 ft (1.5 m) length for the elbow from max. vent length.

1-1 Direct Vent installation examples

Horizontal Installation

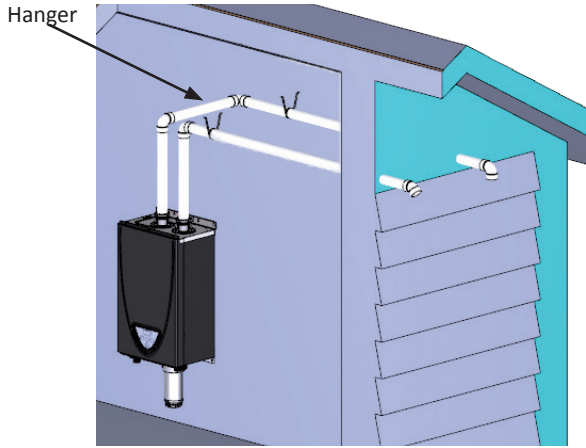

Vertical Installation

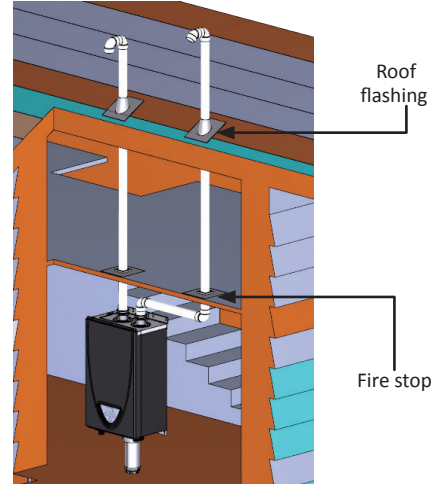

1-2 Power Vent installation examples

Horizontal Installation

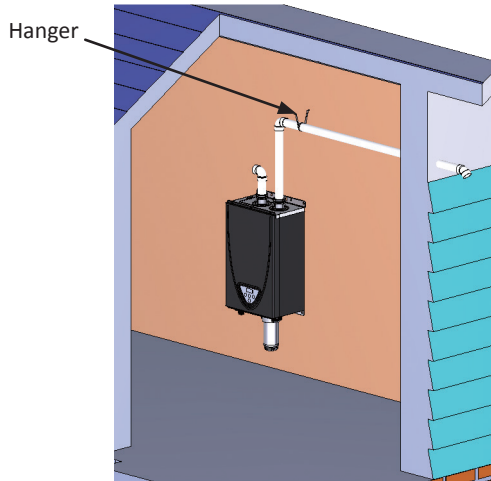

Vertical Installation

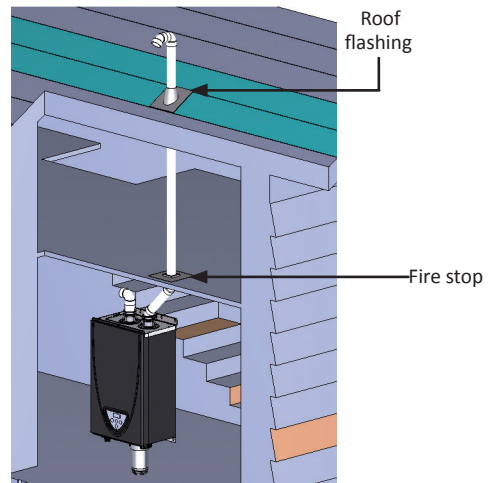

1 -3 Vent terminations

Low profile termination

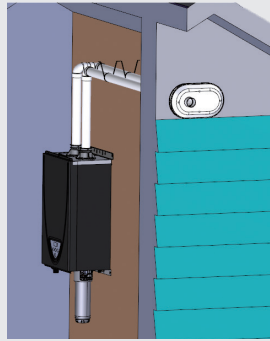

If it is used in vertical position, the exhaust port should be placed in the upper side.

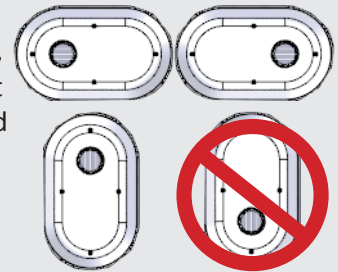

Vent Pipe Size	PVC Kit Number	IPEX PVC Part Number	IPEX System 1738® PVC Part Number
2" Low Profile Term.	100187903	196984	397984
3" Low Profile Term.	100187887	196985	397985

Concentric termination

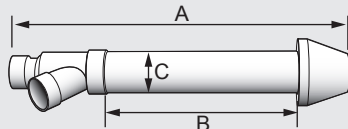

	A	B	C
FGV 2"	29"	16"	2"
FGV 3"	36"	20"	3"

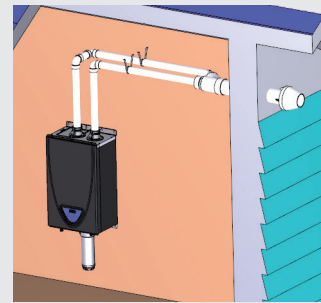

Vent Pipe Size	PVC Kit Number	IPEX PVC Part Number	IPEX System 1738® PVC Part Number	IPEX System 636® CPVC Part Number
2" FGV	100112869	196005	397005	197040
3" FGV	100112163	196006	397006	197006

Polypropylene Concentric Termination

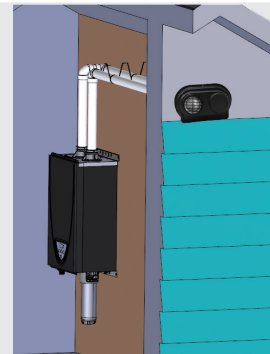

Vent Pipe Size	Centrotherm Part Number
2" Low Profile Term.	ISLPT0202
3" Low Profile Term.	ISLPT0303

INSTALLATION

This page is intentionally blanked.

Step 8: Clearances

-Vent termination clearances-

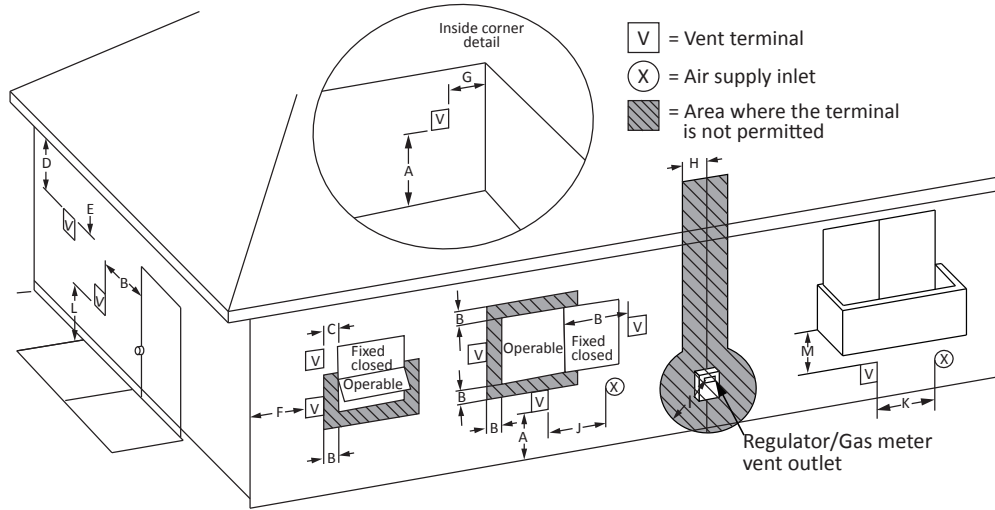

	Canada Installations ¹		US Installations ²	
	Direct vent and other than direct vent	Direct vent	Direct vent	Other than direct vent
A Clearance above grade, veranda, porch, deck, or balcony	1 ft (30 cm)			1 ft (30 cm)
B Clearance to window or door that may be opened	3 ft (91 cm)	1 ft (30 cm)		4 ft (1.2 m) below or to side of opening; 1 ft (30 cm) above opening
C Clearance to permanently closed window	0	0		0
D Vertical clearance to ventilated soffit located above the vent terminator within a horizontal distance of 2 feet (61cm) from the center line of the termination	3 ft (91 cm)	3 ft (91 cm)		3 ft (91 cm)
E Clearance to unventilated soffit	3 ft (91 cm)	3 ft (91 cm)		3 ft (91 cm)
F Clearance to outside corner	2 ft (61 cm)	2 ft (61 cm)		2 ft (61 cm)
G Clearance to inside corner	2 ft (61 cm)	2 ft (61 cm)		2 ft (61 cm)
H Clearance to each side of center line extended above meter/regulator assembly	3 ft (91 cm)	*		*
I Clearance to service regulator vent outlet	Above a regulator within 3 ft (91 cm) horizontally of the vertical center line of the regulator vent outlet to a maximum vertical distance of 15 ft (4.5 m)	*		*
J Clearance to non-mechanical air supply inlet to a building or the combustion air inlet to any other appliance.	3 ft (91 cm)	1 ft (30 cm)		4 ft (1.2 m) below or to side of opening; 1 ft (30 cm) above opening
K Clearance to mechanical air supply inlet	6 ft (183 cm)			3 ft (91 cm) above if within 10 ft (3 m) horizontally.
L Clearance above paved sidewalk or paved driveway located on public property	7 ft (213 cm)**	7 ft (213 cm)		7 ft (213 cm)
M Clearance under veranda, porch deck, or balcony	1 ft (30 cm)***	1 ft (30 cm)***		1 ft (30 cm)***

*Clearance in accordance with local installation codes and the requirements of the gas supplier.

**A vent shall not terminate directly above a sidewalk or paved driveway that is located between two single family dwellings and serves both dwellings.

***Permitted only if veranda, porch, deck, or balcony is fully open on a minimum of two sides beneath the floor.

The vent for condensing water heaters shall not terminate:

- 1). over public walkways; or
- 2). near soffit vents or crawl space vents or other areas where condensate or vapor could create a nuisance or hazard or cause property damage; or
- 3). where condensate vapor could cause damage or could be detrimental to the operation of regulators, relief valves, or other equipment.

Notes:

1) In accordance with the current CSA B149.1, Natural Gas and Propane Installation Code

2) In accordance with the current ANSI Z223.1/NFPA 54, National Fuel Gas Code

-Clearances for sidewall terminations-



Improper installation can result in carbon monoxide poisoning or death. Follow all local and national codes in regards to proper termination clearances. In the absence of such codes, the clearances below can be used as guidelines. Local codes supersede these guidelines.

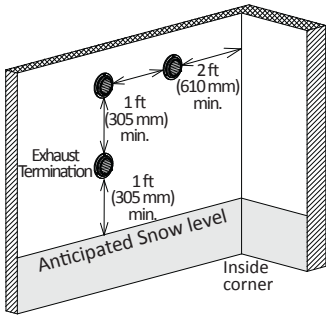

Multiple Sidewall Terminations

- An exhaust termination must be at least:
- 1 ft (305 mm) from another exhaust termination
 - 2 ft (610 mm) from an inside corner

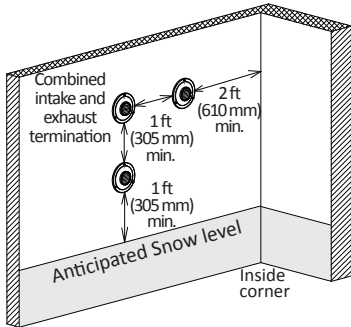
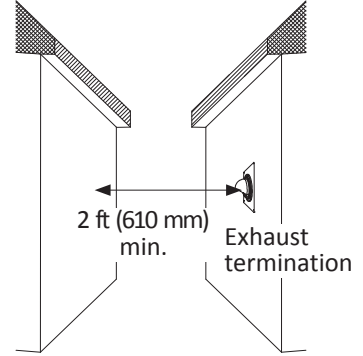

Multiple DV Sidewall Terminations

- A direct vent (DV) termination must be at least:
- 1 ft (305 mm) from other DV terminations
 - 2 ft (610 mm) from an inside corner

Exhaust and/or direct vent sidewall terminations should be at least 2 ft (610 mm) away from an opposite surface/wall. Do not place the termination directly in front of an opening into a building.

For direct vent sidewall terminations that use two separate penetrations for the intake and exhaust, keep the termination clearances shown in the diagrams below.

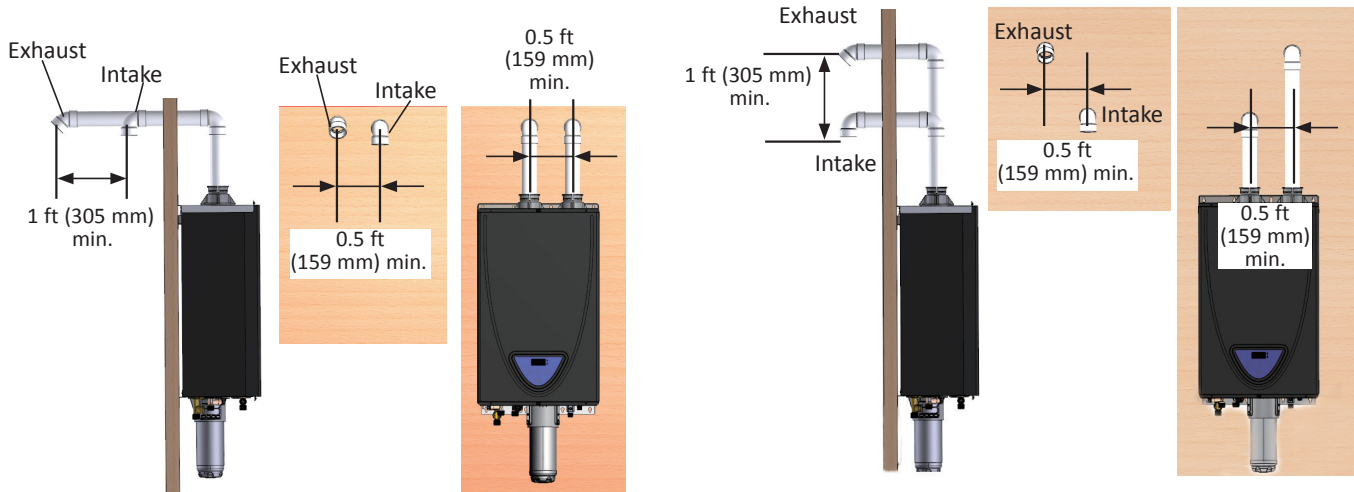

-Clearances for rooftop terminations-



WARNING

Follow all local and national codes in regards to proper termination clearances. In the absence of such codes, the clearances below must be met. Local codes supersede these clearances. Failure to observe this warning may result in severe personal injury or death.

NOTICE

Canadian requirements differ from the guidelines in this section. In Canada, follow the requirements of B149.1 (Natural Gas and Propane Installation Code, current edition) as well as local and provincial codes. Contact your local code enforcement agency for direction.

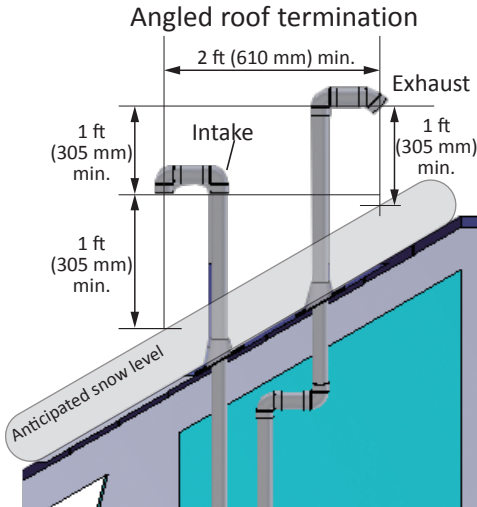

Multiple angled roof terminations

Flat roof termination

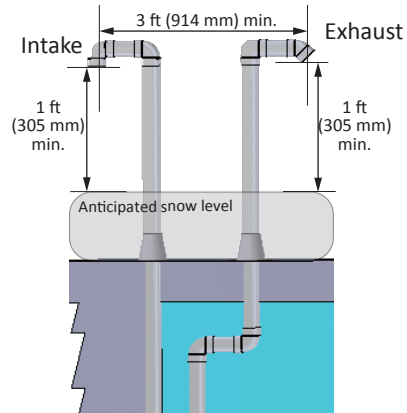

Multiple flat roof terminations

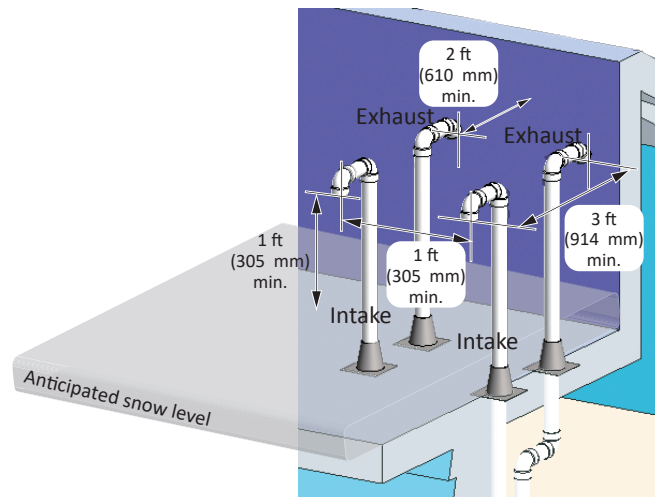
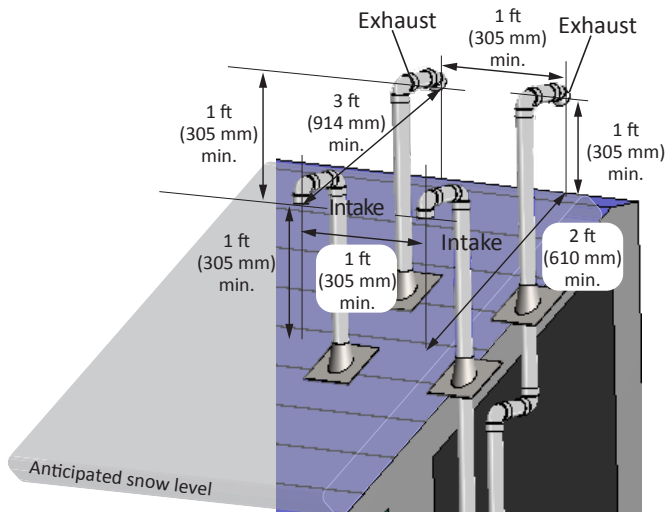

INSTALLATION



WARNING

- Exhaust terminations must be at least 1 ft (305 mm) away from any obstructions.
- Minimum spacing between multiple terminals:
 - intake terminals: 1 ft (305 mm) spacing between each
 - exhaust terminals: 1 ft (305 mm) spacing between each
- The exhaust termination must be a horizontal distance of at least 2 ft (610 mm) from a wall or surface unless specified differently by local code.
- Failure to observe this warning may result in severe personal injury or death.

Step 9: Outdoor installation

Without recess box

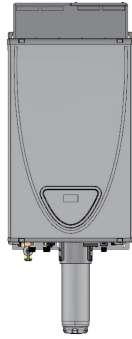

Outdoor Vent Cap 100320424 (TH-VC05) is required.

Included items

100320424 (TH-VC05)		
Vent cap*	Operational panel cover	Junction Box
		

*Use only the vent cap provided in the kit. Do not use any other type or style.

1. Attach the vent cap

Turn off power and gas supply to the water heater. Remove the four screws from the top plate of the water heater as shown in the following figure.

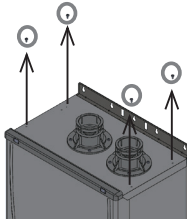

Attach the vent cap to the top of the water heater in the orientation shown below, securing it with the four screws removed in the previous step. Be sure to insert the cylindrical joint into the exhaust port.

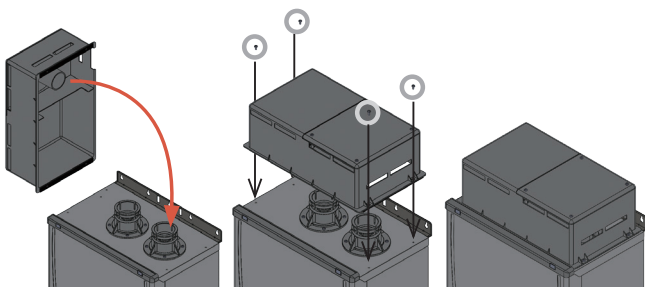

2. Turn the rain guard panel (inside the water heater).

Remove the front cover and remove the built-in controller panel from the holder.

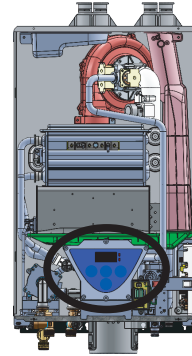

Locate the rain guard panel at the bottom of the unit as shown in the following.

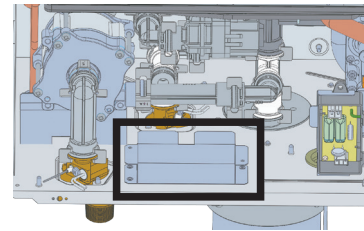

Remove the three screws from the bottom of the unit as follows to detach the rain guard panel.

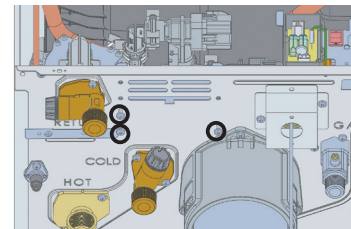

Turn the rain guard panel upside down.

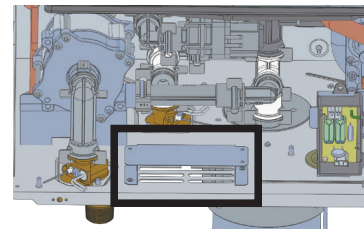

Secure the rain guard panel with the two screws diagonally from outside of the case. (Save the left over screw.)

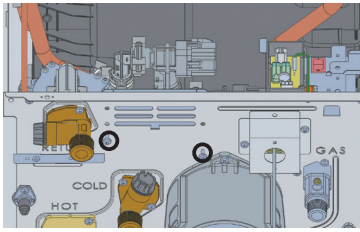

Reinstall the built-in controller panel

3. Change the DIP switch

Remove the screw to pull out the PCB.

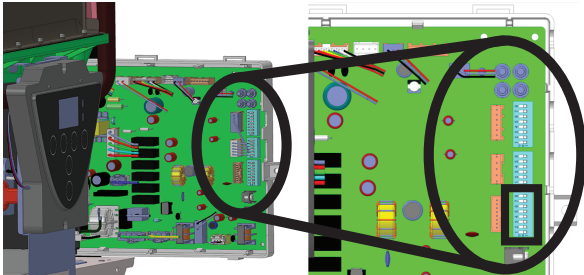

Set DIP switches 3 and 4 on the lower bank as shown in the image below. Do not adjust any other DIP switches.

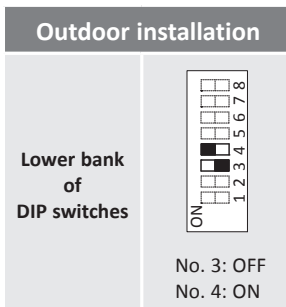

Put back the PCB into the unit.

4. Junction box replacement

The provided junction box will be installed in the location show in the figure below. See the Electrical Connections section in your manual for the steps necessary for the complete outside installation.

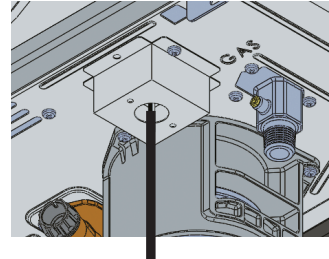

Notice: Check the ground wire in the power wire and be sure to ground the ground wire at the site.

Reinstall the front cover.

5. Attach the operation panel cover

Remove the release paper from the operation panel cover.

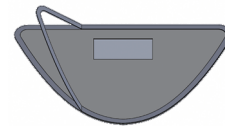

Attach the adhesive side of the operation panel cover to the front cover of the water heater. Use the figure below as a reference for exact placement. Do not attach the operation panel cover directly to the built-in controller.

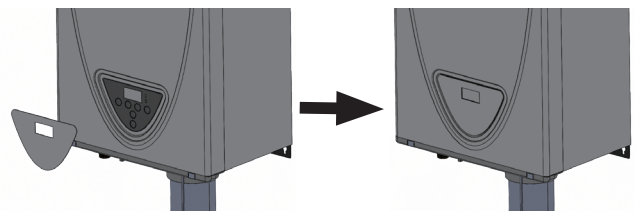

NOTE: Remove the front cover to operate the built-in controller when the water heater is installed outdoors. Optional remote controller is recommended for an easy operation.



Step 10: Gas supply and gas pipe sizing



WARNING

- Check that the type of gas matches the rating plate first.
- Ensure that any and all gas regulators used are operating properly and providing gas pressures within the specified range shown below. Excess gas inlet pressure may cause serious accidents.
- The water heater is set only for Natural gas at the factory. If your gas type is LP Gas, gas conversion shall be required with the included gas conversion kit (100320420) by a qualified installer. (Refer to pp. 11 and 33.)
- Failure to follow these warnings could result in severe personal injury, carbon monoxide poisoning, or death.

- **DO NOT** attach the gas line to the water heater until after supply line pressure testing has been completed to avoid any damage to the water heater.
- The minimum and maximum inlet gas pressures are:

Gas type	Inlet gas pressure
Natural Gas	Min 3.5" W.C. (0.87 kPa) – Max. 10.5" W.C. (2.62 kPa)
Propane	Min 8.0" W.C. (1.99 kPa) – Max. 13.0" W.C. (3.24 kPa)

- Inlet gas pressures that fall outside the range of values listed above may adversely affect the performance of the water heater. These pressures are measured when the water heater and any other gas appliance served by the same gas line are in full operation.
- Inlet gas pressure must not exceed the above maximum values; gas pressure above the specified range will cause dangerous operating conditions and damage to the unit.
- If the gas supply pressure to the heater is greater than the specified maximum, a field-supplied regulator is required. The regulator must lower the gas pressure within the approved range.
- Install the gas regulator according to the manufacturer's instructions. Some manufacturers may require a certain amount of straight pipe on the outlet prior to any additional fittings.
- The regulator must be sized for the water heater's minimum to maximum input and provide the specified pressures that are listed on the rating plate.
- In the absence of minimum install distance stated by the regulator manufacturer, it is recommended that there is at least 3 ft (1 m) of piping between the regulator outlet and the water heater's inlet gas connection.

-Gas connections-

A Gas Water Heater Hook-Up Kit is available at your local plumbing supplier, it includes a flexible gas connector with compression fittings to connect the home's gas line to the water heater's gas control valve. Follow the kit's installation instructions to attach the flexible gas connector.

1. Use a 1/2" union to connect gas piping to the water heater's 1/2" male NPT connection.
2. Install a full port manual gas shutoff valve between the water heater and the gas supply line.
3. When the gas connections are completed, it is necessary to perform a gas leak test either by applying soapy water to all gas fittings and observing for bubbles or by using a gas leak detection device.
 - The water heater and its individual shutoff valve must be disconnected from the gas supply piping system during any pressure testing of that system at test pressures in excess of 1/2 psi (3.5 kPa).
 - The water heater must be isolated from the gas supply piping system by closing its individual manual shutoff valve during any pressure testing of the gas supply piping system at test pressures equal to or less than 1/2 psi (3.5 kPa).
4. Always purge the gas line of any debris and/or water before connecting to the gas inlet.

STANDARD GAS PIPING CONFIGURATION

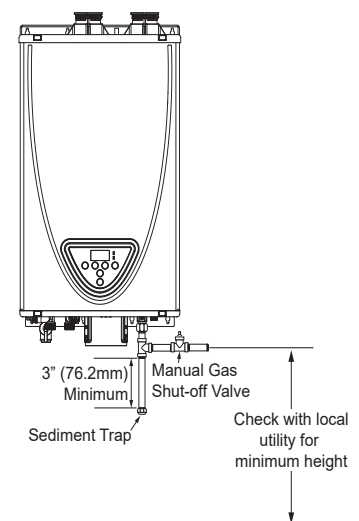

NOTICE

Size the gas pipe appropriately to supply the necessary volume of gas required for the water heater using ANSI Z223.1/NFPA 54 in the USA or B149.1 in Canada or local codes. Otherwise, flow capabilities and output temperatures will be limited.



-Natural gas supply piping-

Maximum delivery Capacity in Cubic Feet of Gas per Hour (based on IPS Pipe carrying Natural Gas with 0.60 Specific Gravity with a Pressure Drop of 0.5" W.C.).

Based on Energy Content of 1,000 BTU/Cubic ft: The water heater requires 199 ft³/h for the 199X3P, 180 ft³/h for the 180X3P, 160 ft³/h for the 160X3P.

The following tables are from ANSI Z223.1/NFPA 54.

Unit: Cubic feet per hour

Pipe Size Diameter	Length												
	10' (3.0 m)	20' (6.1 m)	30' (9.1 m)	40' (12.2 m)	50' (15.2 m)	60' (18.3 m)	70' (21.3 m)	80' (24.4 m)	90' (27.4 m)	100' (30.5 m)	125' (38.1 m)	150' (45.7 m)	200' (61.0 m)
1/2"	172	118	95	81	72	65	60	56	52	50	44	40	34
3/4"	360	247	199	170	151	137	126	117	110	104	92	83	71
1"	678	466	374	320	284	257	237	220	207	195	173	157	134
1-1/4"	1,390	957	768	657	583	528	486	452	424	400	355	322	275
1-1/2"	2,090	1,430	1,150	985	873	791	728	677	635	600	532	482	412
2"	4,020	2,760	2,220	1,900	1,680	1,520	1,400	1,300	1,220	1,160	1,020	928	794

-Propane (LP) supply piping-

Maximum Capacity of Propane (LP) Based on 11" W.C. supply pressure at a 0.5" W.C. pressure drop

Unit: kBtu per hour

Pipe Size Diameter	Length												
	10' (3.0 m)	20' (6.1 m)	30' (9.1 m)	40' (12.2 m)	50' (15.2 m)	60' (18.3 m)	70' (21.3 m)	80' (24.4 m)	90' (27.4 m)	100' (30.5 m)	125' (38.1 m)	150' (45.7 m)	200' (61.0 m)
1/2"	268	184	148	126	112	101	93	87	82	77	68	62	53
3/4"	567	393	315	267	237	217	196	185	173	162	146	132	112
1"	1,071	732	590	504	448	409	378	346	322	307	275	252	213
1-1/4"	2,205	1,496	1,212	1,039	913	834	771	724	677	630	567	511	440
1-1/2"	3,307	2,299	1,858	1,559	1,417	1,275	1,181	1,086	1,023	976	866	787	675
2"	6,221	4,331	3,465	2,992	2,646	2,394	2,205	2,047	1,921	1,811	1,606	1,496	1,260

Gas sizing example (Natural Gas)

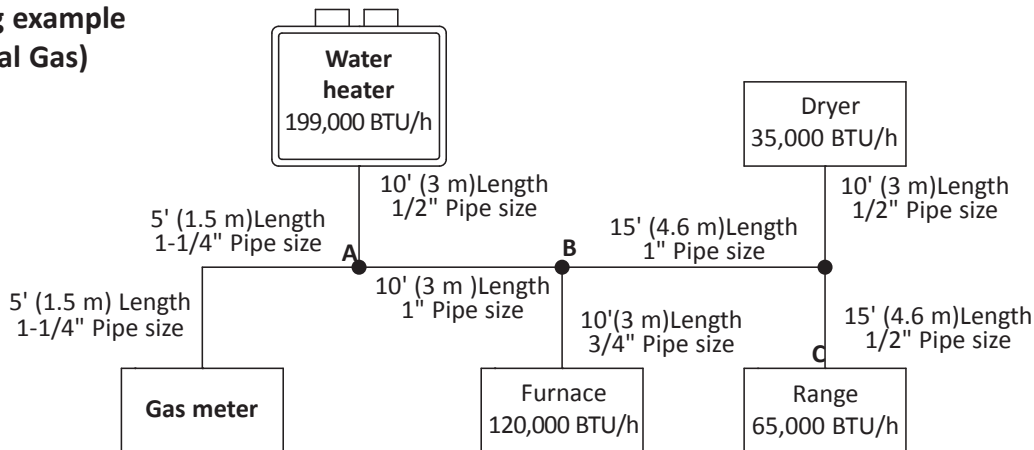

Based on Energy Content of 1,000 BTU/Cubic ft:

Divide each appliance's BTU/h requirement by 1,000 BTU/ft³ to get the appliance's ft³/h requirement.

Take into account the distance the appliance is from the gas meter, look in the above gas chart to properly size the line.

For sections of the gas line supplying gas to more than one appliance (Ex: Point A to Point B), add up the cubic ft per hour requirements of the appliances that are being supplied by that section, and size to the farthest appliance.

For Example: The section from A to B supplies gas to the furnace, range and dryer. Adding up the BTU/h requirements and dividing by 1,000 yields a cubic ft per hour requirement of 220 cubic ft of gas per hour. The farthest appliance is the range, which is 50 ft away from the meter. Looking at the above chart, and under the column of 50 ft, Section A to B needs to be 1" in order to supply 220 cubic ft.

Step 11: LP gas conversion

This water heater is configured for Natural Gas from the factory. However, if a field conversion to Propane Gas is necessary, the conversion kit supplied with the water heater must be used and installed by a qualified service agency*. Before you install the components in this Propane Gas conversion kit, verify the type of gas that will be used to fuel the unit.

WARNING! An improper field conversion could cause potentially dangerous conditions that may cause an explosion or fire resulting in property damage, bodily injury or both.



- This conversion kit shall be installed by a qualified service agency* or a gas utility service technician in accordance with Manufacturer’s written instructions and all applicable codes and requirements of the authority having jurisdiction. The information in these instructions must be followed to minimize the risk of fire or explosion or to prevent property damage, personal injury or death. The qualified service agency* is responsible for the proper installation of this kit. The installation is not proper and complete until the operation of the converted appliance is checked as specified in the manufacturer’s instructions supplied with the kit.
- **If your water heater has been converted to use a different gas type in the past, the manufacturer does NOT recommend converting it again.**
- **IN CANADA, THE CONVERSION SHALL BE CARRIED OUT IN ACCORDANCE WITH THE REQUIREMENTS OF THE PROVINCIAL AUTHORITIES HAVING JURISDICTION AND IN ACCORDANCE WITH THE REQUIREMENTS OF THE CSA-B149.1, NATURAL GAS AND PROPANE INSTALLATION CODE.**

* A qualified service agency is any individual, firm, corporation or company which either in person or through a representative is engaged in and is responsible for the connection, utilization, repair or servicing of gas utilization equipment or accessories; who is experienced in such work, familiar with all precautions required, and has complied with all of the requirements of the authority having jurisdiction.

Tools Required:

- Phillips Screwdriver
- Manometer
- Gas Leak Detector

LP gas conversion kit: 100320420

LP Gas Orifice*	Orifice gasket (100320382)	Gas Conversion Label

*Orifice plate

A Propane orifice plate will have the NA drilled out. A Natural Gas orifice plate will have the LP drilled out. The image on the left illustrates a Propane orifice plate.



- Before servicing the water heater, make sure that electrical power and gas service to the water heater is turned OFF. Failure to do so may result in bodily injury, death, or property damage.
- Failure to observe the following warnings may result in gas leaks, resulting in serious injury or death.
 - Hand tighten the screws.
 - Do not overtighten as this may damage or crack the components.
 - Do not use a powered screwdriver.

Gas conversion procedure:

1. Turn off power supply.
2. Turn off both gas and water valves to the water heater.
3. Remove the front cover by removing the four screws securing it to the water heater.
4. Locate the gas solenoid valve assembly in the upper part of the water heater. (Figure 1 on p.34)
5. Detach the fastener securing the inlet gas pipe to the gas solenoid valve assembly to remove it. Pull the inlet gas pipe from the solenoid. (Figure 2 on p. 34)
6. Use a Phillips screwdriver to remove the 3 screws from the gas solenoid valve assembly and detach the gas solenoid valve assembly from the fan motor unit shown in Figures 3 & 4 on p. 34.
7. Remove the NG orifice plate and gasket from the gas solenoid valve assembly by removing the 2 screws (Figure 5 on p. 34).

8. Install the LP orifice plate and gasket on the gas solenoid valve assembly as shown in Figure 5. Secure the orifice plate by hand tightening the 2 screws. Ensure that the orifice, gasket and two screws are in good condition and not compromised in any way. If damage is found replace them with new ones. (Part number: 100320420) Improper installation of the orifice and gasket may cause a gas leak.
9. After checking an oval ring is in a good position in the venturi, install the gas solenoid valve assembly to the venturi as shown in Figure 4. Use a Phillips screwdriver to hand tighten the 3 screws to secure the assembly (Figure 3).
10. Inspect the o-ring on the gas supply tube. If there is any damage, replace it with part number 100320422. Insert the tube into the gas valve assembly. Secure the tube to the assembly by inserting the fastener over the gas supply tube.
11. Locate the PCB in the right side of the bottom of the water heater case and remove the screw indicating in Figure 1.
12. Pull out the PCB and set the DIP switches on the PCB to the correct position for propane by setting DIP switch #1 of the lower bank to the ON position and DIP switch #2 to the OFF position as shown in Figures 6.
13. Put back the PCB into the case and reattach the removed screw. (Figure 1)
14. Verify that the gas supply pressure is within an acceptable range. (Refer to “Gas Supply and Gas Pipe Sizing for Propane” on p.31.)
15. After the water heater has been installed and the gas line pressure test has been completed, perform the following steps:
 - a. Turn on the water supply.
 - b. Turn on the gas supply.
 - c. Turn on electrical power.

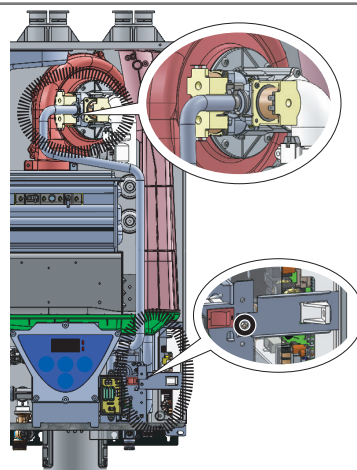

Figure 1

16. Check for gas leaks around the water heater as follows:
 - a. Turn on a nearby hot water faucet.
 - b. Wait until a consistent flame is seen through the sight glass.
 - c. Check for gas leaks by running a gas leak detector along the gas passage. If you find a leak, stop operating the water heater and turn the gas supply off.
17. Turn off the hot water faucet.
18. After the water heater has completed its post-purge process, turn off the gas supply and turn off power to the water heater.
19. Verify the static and dynamic gas pressures for the water heater. Refer to the step no. 3 to 16 of “Measuring inlet gas pressure” in this manual.
20. Check the combustion status as described on the following page.
21. Put back the PCB into the case and reattach the removed screw. (Figure 1)
22. Reinstall the front cover with the removed four screws.
23. Fill out all items on the gas conversion sticker with a permanent marker. Affix the label on the heater as shown in Figure 7.
24. Restart the water heater according to the Installation Manual and Owner’s Guide.

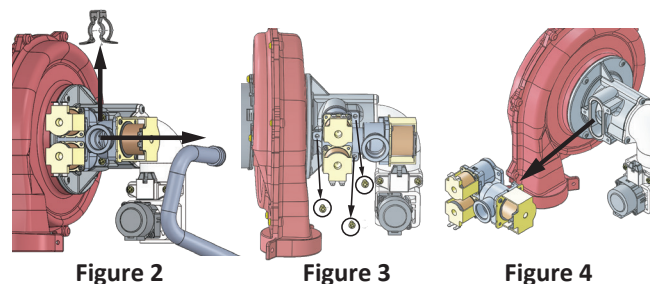

Figure 2

Figure 3

Figure 4

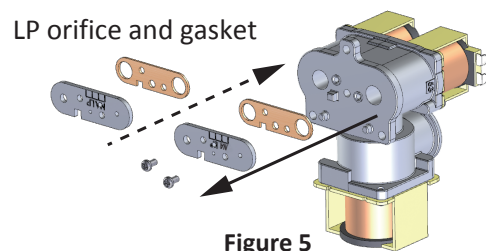

Figure 5

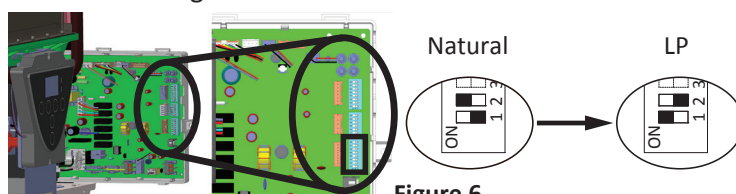

Figure 6

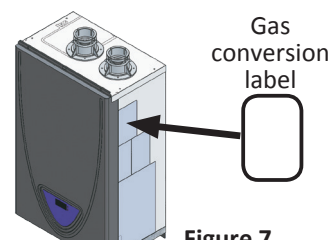

Figure 7

Verify proper operation before returning the water heater to service.

Check combustion status - measuring CO₂ value using a CO₂ gas meter

Tools Required: Phillips Screwdriver, T-15 Torx driver, CO₂ Gas meter

1. Ensure that the water heater is not in operation.
2. Locate the outlet venting port and remove the screw and the cover off the outlet venting port. (Figure A)
3. Connect a CO₂ gas meter to the outlet venting port. (Figure A)
4. Turn on power supply to the water heater.
5. Turn on both gas and water valves to the water heater.
6. Check if the PCB is pulled out. (Figure B)
7. Turn on hot water fixtures to produce a flow to activate the water heater.
8. Verify the **Minimum combustion** as follows:
 - a. Press and hold the “MIN” button on the PCB. (See Figure B.)
 - b. Compare the reading on the CO₂ gas meter to the values in the table below.* If it does not fall within the acceptable range, refer to the following “Adjusting gas ratio at minimum combustion.”

*It may take some time for the CO₂ gas meter to become stable.

Adjusting gas ratio at minimum combustion

- i. Locate the adjusting port on the gas valve. (See Figures A and C.)
- ii. Remove the screw cover from the adjusting port with a T-15 Torx driver.
- iii. Press and hold down the “MIN” button on the PCB. While holding down the “MIN” button, turn the screw clockwise to increase or turn the screw counterclockwise to decrease the CO₂ value and fall into the range of CO₂ value in the table below with the driver. (See Figure C.)
- iv. Verify the Maximum combustion to confirm proper combustion status after adjusting as follows.
 - a. Turn on hot water fixtures to produce a high flow. If an isolation valve is installed, hook up a water hose to the hot outlet and run water at maximum rate.
 - b. Press and hold the “MAX” button on the PCB. (See Figure B.)
 - c. Compare the reading on the CO₂ gas meter to the values in the table below.* If it does not fall within the acceptable range, refer to the above “Adjusting gas ratio at minimum combustion.”

*It may take some time for the CO₂ gas meter to become stable.

9. After gas ratio has been adjusted, turn off the power supply and turn off both gas and water valves. Next, replace the adjusting port screw securely. If the screw isn’t fastened securely at this time, it may cause a gas leak.
10. Remove the CO₂ gas meter from the outlet venting port and reinstall the removed cover on the outlet venting port with the removed screw. (Go back to **the step 21 of Gas conversion procedure.**)

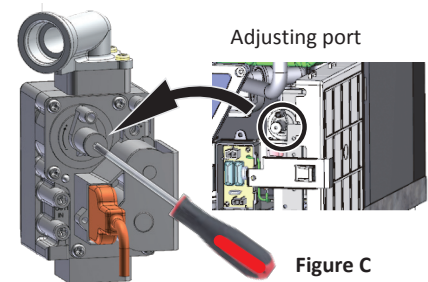
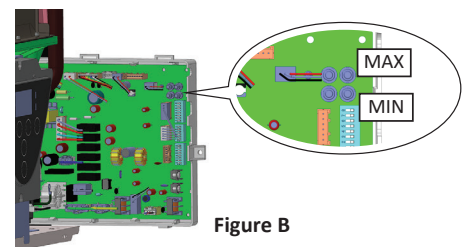
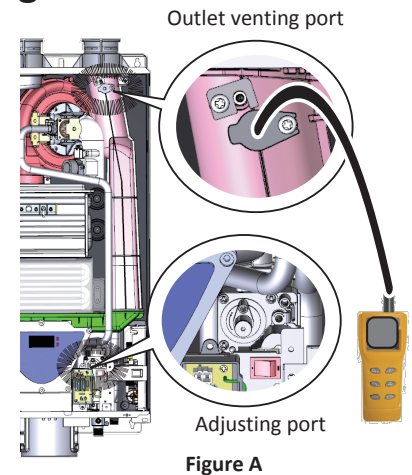

- CO₂ value -

Models for Propane		160X3P		180X3P		199X3P	
CO ₂ value	%	Max.	10.2 ± 0.5	Max.	10.2 ± 0.5	Max.	10.2 ± 0.5
		Min.	10.3 ± 0.5	Min.	10.3 ± 0.5	Min.	10.3 ± 0.5
BTU Input	BTU/h	Max.	160,000	Max.	180,000	Max.	199,000
		Min.	9,000	Min.	9,000	Min.	9,000



Step 12: Water connections



WARNING

Do not use this appliance if any part has been under water. Immediately contact a qualified installer or service agency to replace a flooded water heater. Do not attempt to repair the unit! It must be replaced!

NOTICE

Do not reverse the hot outlet and cold inlet connections to the water heater. If you reverse the connections, the water heater will not activate properly.

Determine the type of water pipes in your home. Most homes use copper water pipes, but some use CPVC or cross-linked polyethylene (PEX). Use fittings appropriate for the type of pipe in your home. Do not use iron or PVC pipe – they are not suitable for potable water. All pipes, pipe fittings, valves and other components, including soldering materials, must be suitable for potable water systems. Also, an automatic air vent or air separator must be installed when the water heater operates in a closed loop system such as a recirculation system. Trapped air bubbles in the water system can cause a pump to cavitate or damage the water heater's heat exchanger. This equipment must be installed according to its manufacturer's instructions.

- A manual shutoff valve must be installed on the cold water inlet to the water heater between the main water supply line and the water heater.
- A thermal expansion tank or code approved device to handle thermal expansion must be installed.
- Connect the cold water supply using 3/4 inch National Pipe Thread "NPT" to the fitting marked "C" (COLD).
- For ease of removing the water heater for service or replacement, connect the water pipes with a coupling called a union. We recommend using a dielectric-type union (available at your local plumbing supplier). Dielectric unions can help prevent corrosion caused by tiny electric currents common in copper water pipes and can help extend the life of the water heater.
- Connect the hot water supply using 3/4 inch NPT to the fitting marked "H" (HOT). Follow the same connection guidelines as for the cold water supply.
- In addition, a manual shutoff valve is also recommended on the hot water outlet and return inlet of the unit.
- Double check to make sure the hot and cold water pipes are connected to the correct hot and cold water fittings on the water heater.
- If needed, install (or adjust) the home's Pressure Reducing Valve and a thermal expansion tank or code approved device to handle thermal expansion must be installed.
- Before installing the water heater, flush the water line to remove all debris, and after installation is complete, purge the air from the line. Failure to do so may cause damage to the heater.
- There is a wire mesh filter within the cold inlet and return inlet to trap debris from entering your heater. This will need to be cleaned periodically to maintain optimum flow. (Refer to p. 68.)
- Install insulation (or heat tape) on the water pipes especially if the indoor installation area is subject to freezing temperatures. Insulating the hot water and return pipes will reduce heat loss.
- If water hammer is evident install water hammer arrestors on the inlet side.
- Water lines with temperatures exceeding 110°F (43°C) should not be connected to the cold inlet of the water heater where water will flow through the X3™ Technology Cartridge. Damage to the cartridge will result.

IF YOU HAVE COPPER PIPES:

If your home has copper water pipes, you can solder the water pipe connections or use compression fittings which don't require soldering. Compression fittings are easier to install than soldering pipe. Check with local plumbing officials to determine what types of pipe materials are suitable for your location. Do not use lead-based solder.

NOTICE

Do not solder pipes while they are attached to the water heater. The water heater contains non-metallic parts which could be damaged. The proper way to connect the water heater to copper water pipes is as follows:

- Solder a short length of pipe (about a foot or so) to a threaded adapter using only 95/5 tin antimony or equivalent solder.
- Attach the threaded adapters to the water heater's connections (using thread sealant tape or pipe joint compound).
- Connect the home's water pipes by soldering, keeping the connections at the water heater cool with wet rags.

Model		Indoor	Outdoor
Maximum Pipe length* (Hot Water supply line and Dedicated Return line)	Pipe Diameter 3/4"	500 ft (152.4 m)	
	Pipe Diameter 1/2"	200 ft (61 m)	

*These are equivalent length that includes head loss for elbows, tees, unions, etc for smooth wall copper tube. Other water tube materials have different head loss characteristics. When other materials are used, the installer shall consult with the water tube manufacturer to conduct a head loss calculation to make sure the installed pump will flow at least 2 gpm. Please refer to the manufacturer's specification sheet for pump head loss information. An additional pump may be necessary for circulation systems with longer equivalent pipe lengths.



RECIRCULATION PUMP MODES:

The X3P water heater comes with an integrated recirculation pump. The water heater has 3 recirculation mode options; Recirculation with a dedicated return line (default), On-Demand mode compliant with California's Title 24, and Crossover recirculation mode. Details of the operation are listed below. In each mode, the heater's pump only operates when there is not any demand from the home's fixtures. The water heater will stop the pump if there is a call for demand from one of the home's fixtures.

1. **Recirculation with a Dedicated Return Line (Default Mode)** - In this mode, the water heater will operate the pump in order to keep your water lines warm, reducing the time it takes for the hot water to arrive at the fixture. The user can configure 2 Pump Timer ON periods where the heater will operate the pump. It is recommended to set the Pump Timers to ON during times when the home is occupied. The water heater will operate as an on-demand water heater during Pump Timer Off periods, though there may be a delay getting hot water to the fixture. See p. 60 to set the Pump Timers.
2. **On-Demand Mode** - In this mode, the pump will only activate when the user pushes the "Pump" button on the heater's built in controller or accessory remote controller. See p. 64 for additional information. This mode is compliant with California's Title 24.
3. **Crossover Valve Mode** - In this mode, a "crossover" valve is typically installed at the home's furthest fixture. This valve will use the home's cold water line to act as the return line. The settings on the valve are dependent on the manufacturer. For example the typical operation is as follows; the crossover valves have a type of thermal valve that will open up when the water temperature on the hot side drops below 95°F (35°C) and will close when the temperature reaches 105°F (40.5°C). NOTICE: These temperature values may vary from manufacturer to manufacturer. To set the water heater to this mode, you must move the #5 DIP switch on the upper bank to the ON position. (See p. 39 for Crossover Valve Installation.) The water heater will operate its pump. When it detects that the crossover valve is closed, it will stop the pump. By default, the heater will check to see if the valve is opened 20 minutes after the last operation. If the valve is open, the heater will operate until the valve closes. This time interval can be reduced to 10 minutes by moving the #3 DIP switch on the upper bank to the ON position.

NOTICE

- Check valves must be installed on both of the cold water line and return line. Please refer to the diagram below.
- Check valves aren't necessary for the crossover install.
- Insulate the hot water supply line and dedicated return line to prevent heat loss.
- The recirculation flow rate should not exceed 4.2 gpm (16 L/min.)

-Standard recirculation-

LEGEND	
	TEMPERATURE & PRESSURE RELIEF VALVE
	PRESSURE RELIEF VALVE
	CIRCULATION PUMP
	TEMPERATURE CONTROL PROBE
	DRAIN
	BALL VALVE
	CHECK VALVE
	TEMPERATURE GAUGE
	WATER FLOW SWITCH
	CAPPED LINE
	COLD
	HOT
	BUILDING RETURN
	GAS

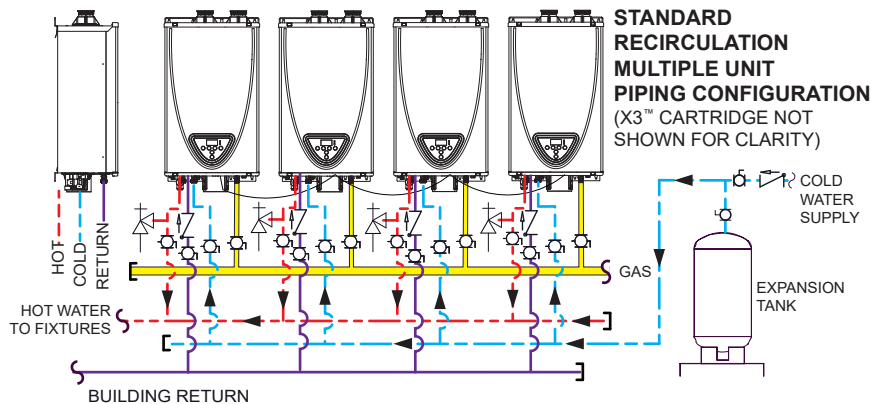
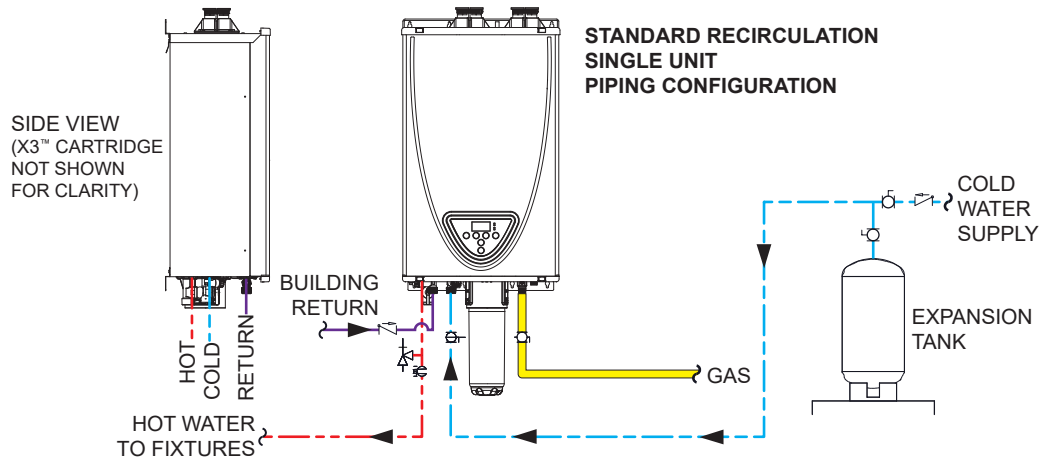

-Standard non - recirculation-

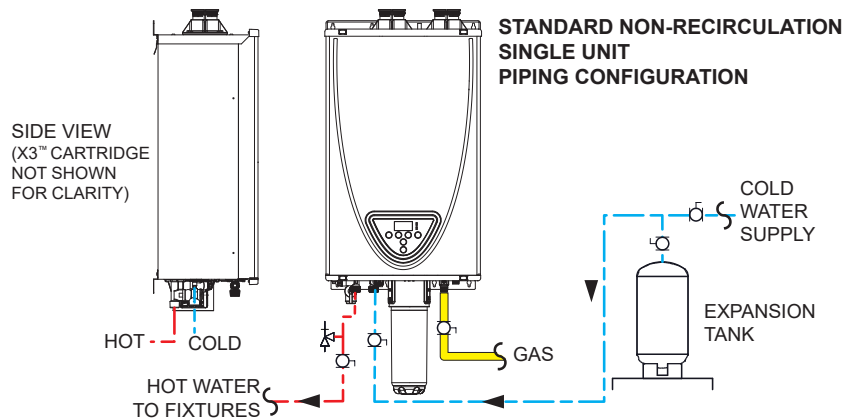

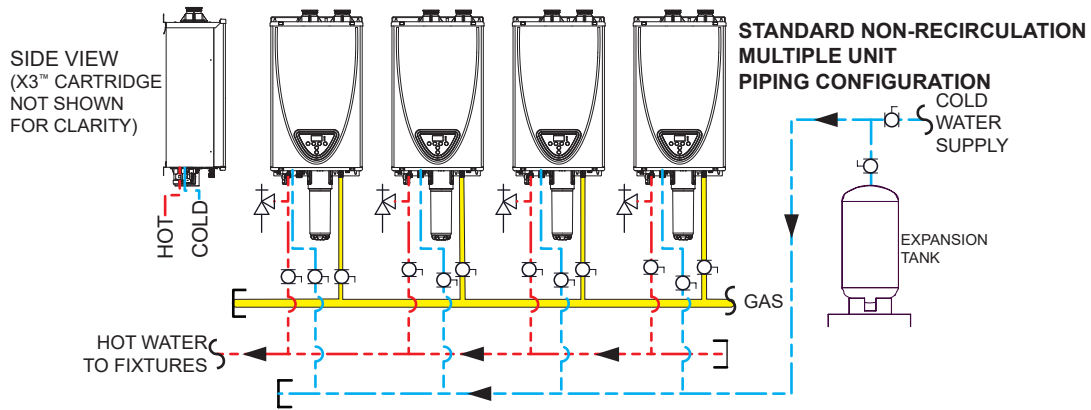

-Recirculation with cross over valve-

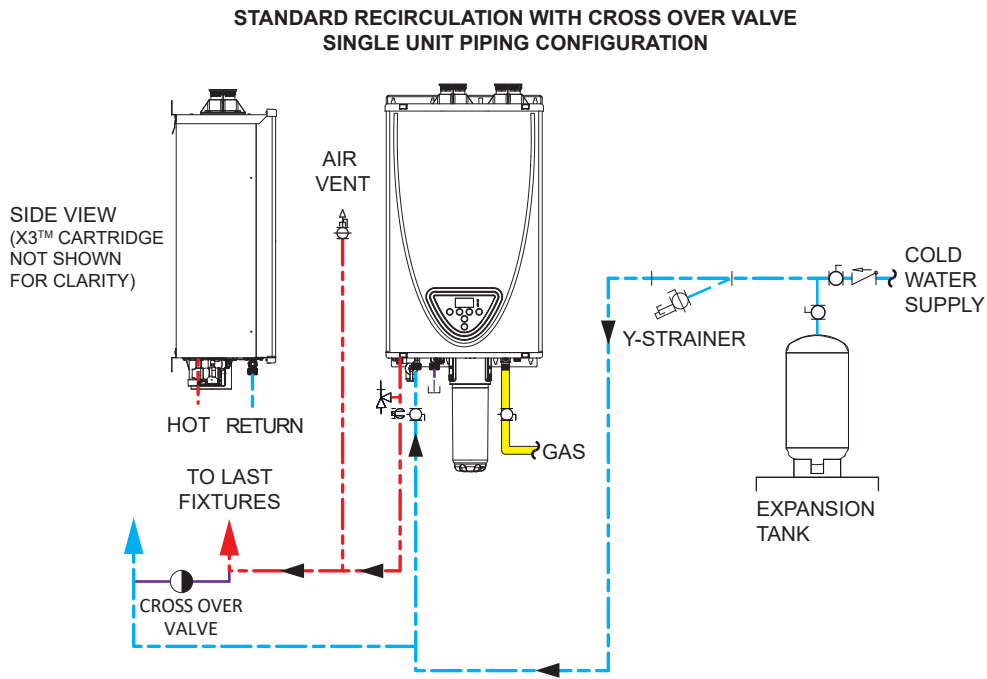

CROSS OVER VALVE DOES NOT COME WITH THE WATER HEATER

NOTICE

The inner water tubing must be rearranged when using a cross over valve for recirculation. Follow the procedure on the next page.



WARNING

- Before changing pipes and DIP switch settings, make sure that electrical power and gas service and water supply to the water heater are turned OFF. Failure to do so may result in bodily injury, death, or property damage.
- Improperly connected pipes can cause water leaks. Make sure that each o-ring is installed and in good condition. Each of the metal fasteners should snap into place and spin freely around the joint once seated.

Crossover valve procedure

1. Turn off the power supply to the water heater.
2. Remove the front cover and built-in controller operational panel.
3. Use the image below as reference to locate the pipes and connections that will be changed

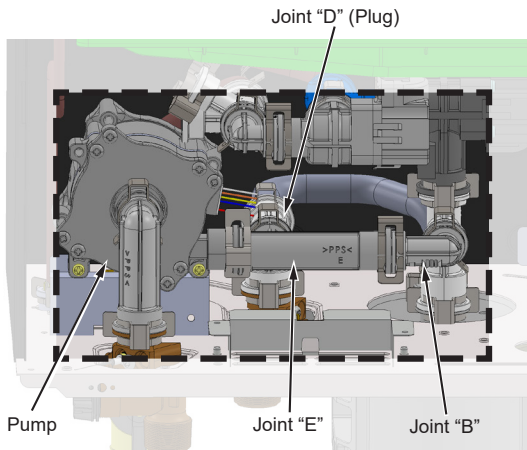

4. Locate Joints "E" and "B" and remove as indicated in the image below. Remove Joints "E" and "B" from the water heater as shown.

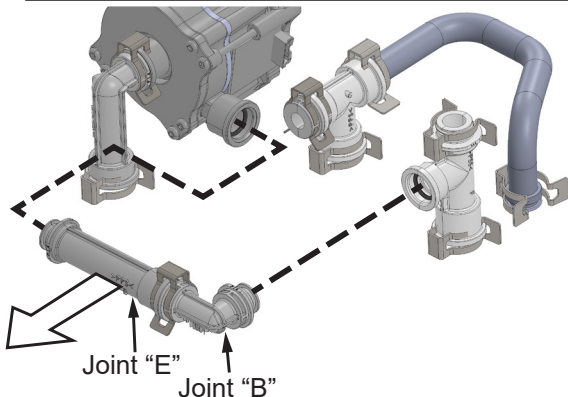
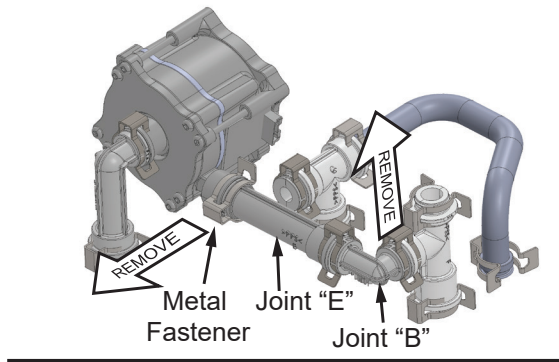

5. Remove the metal fastener connecting Joint "E" to Joint "B". Reattach the metal fastener to Joint "E" and store this with your water heater. It will not be used in this configuration but may be needed later if piping configurations are changed.

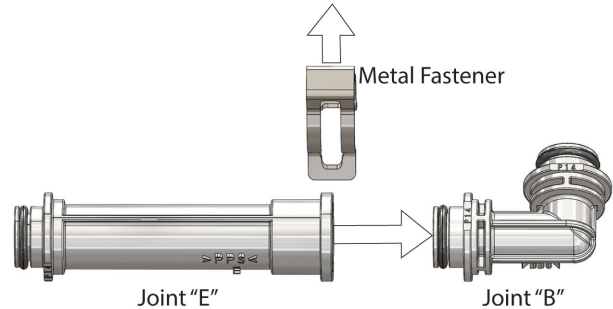

6. Remove the metal fastener on Joint "D" and detach the plug. Reattach the plug to Joint "F". Attach the metal fastener to secure the connection at Joint "F". NOTICE: The plug MUST be installed into Joint "F". DO NOT proceed to the next step until this is completed.

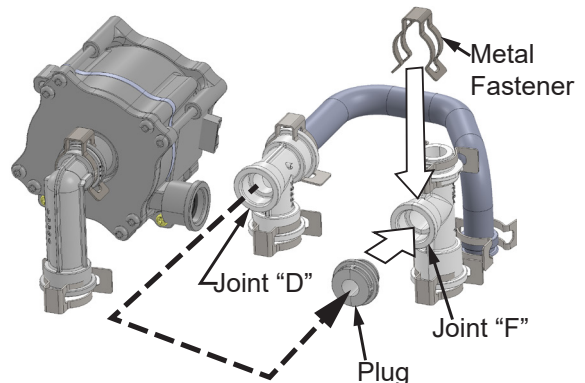
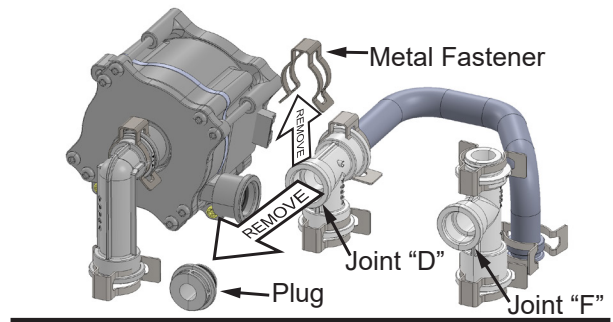

7. Reattach Joint "B" using the image below as a reference guide. Note the orientation of Joint "B", one side of the pipe is longer and should be configured as shown below. Reattach the metal fasteners at both connection points.

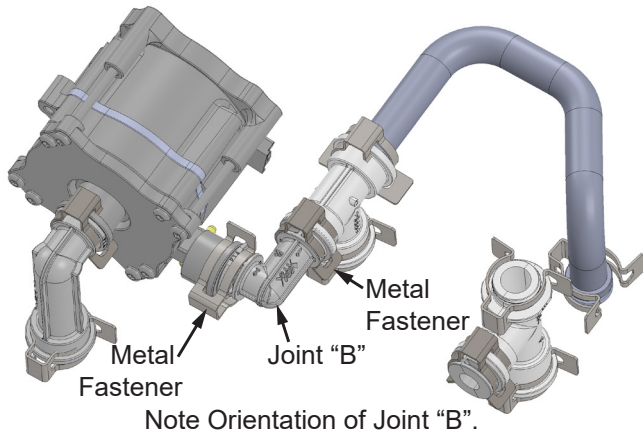

8. Before proceeding to the next step, check all connections and slowly turn on the water. Check for any leaks and if any are present fix immediately.

9. Locate and remove the sheet metal panel and screw securing the printed circuit board. Slide the board forward to access the DIP switches. Use the image below to locate the top bank of switches and set switch 5 to the ON position as shown in the image below.

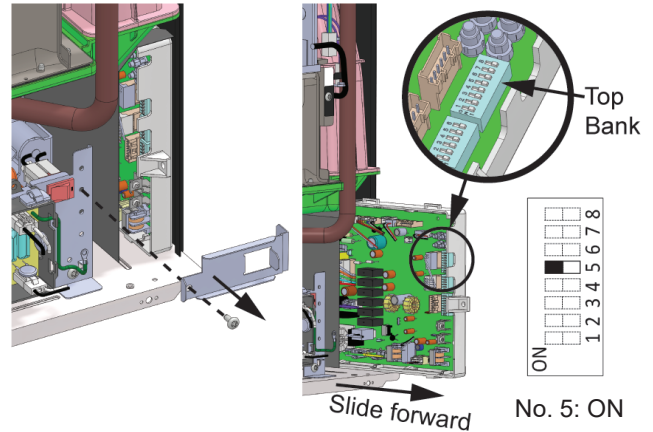

10. Slide the Board back into place and reattach the sheet metal panel.

11. Reattach the built-in controller panel and cover.

12. Turn on the power supply to the water heater.

13. Check the display for any codes to verify proper operation.

-Installation without recirculation-disable pump function-

NOTICE

- PUMP TIMER 1 and PUMP TIMER 2 must be set to OFF if you use this installation method.
- Cold water supply line must be connected to the "Return inlet".
- The "Cold water inlet" must be capped.

Use this method when recirculation is not used (such as when the return line will be installed later). Before the water heater is put into service, ensure that no timers are set to activate the pump. See "Pump Operation Timers."

- Install the water supply line to the "Return inlet" water connection.
- Install a 3/4" end cap to the "Cold water inlet" connection.
- Follow steps 1-8 on pp. 40 and 41 to adjust the tubing.

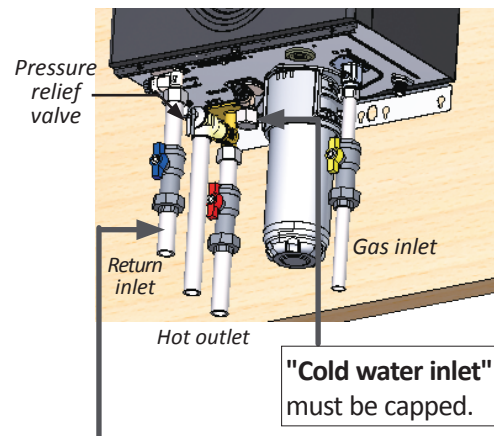

Cold water supply line must be connected to the "Return inlet".



-X3™ Technology-

This water heater is equipped with X3™ Scale Reduction Technology to inhibit scale formation within the heat exchanger tubing of this unit. Part of the X3™ Technology's anti-scale protection comes from the special X3™ Cartridge media. The X3™ Cartridge must be installed into the manifold located on the underside of the heater cabinet prior to operation of the unit (shown as follows). The X3™ system is designed to be hassle-free; eliminating the need to drain the heater for installation, removal, or replacement of the cartridge. X3™ Scale Reduction Technology reduces the formation of scale in the heat exchanger, extending the operating life of the unit in typical potable water installations. Specific water conditions may impact the efficiency of X3™, such as excessive iron or manganese levels. Refer to the guidelines below and consult a water quality expert to determine if your water is within acceptable X3™ and EPA guidelines.

X3™ Technology Installation/Removal

Installation - Insert the X3™ Cartridge into the X3™ manifold and turn it right until the  symbol aligns with the .

Removal -

1. Close the shutoff valve on the cold water supply.
2. Turn off the power supply.
3. Open a hot water fixture to relieve water pressure in the heater.
4. If a drain pan is not installed, place a bucket or pan underneath the X3™ Cartridge as some water may be present when removing.
5. Turn the X3™ Cartridge left until the  symbol aligns with the .
6. Pull down to remove it from the water heater. It is normal for a small amount of water to drip. NOTE: the cartridge will be full of water. Take care to not tilt it till you can drain the water.

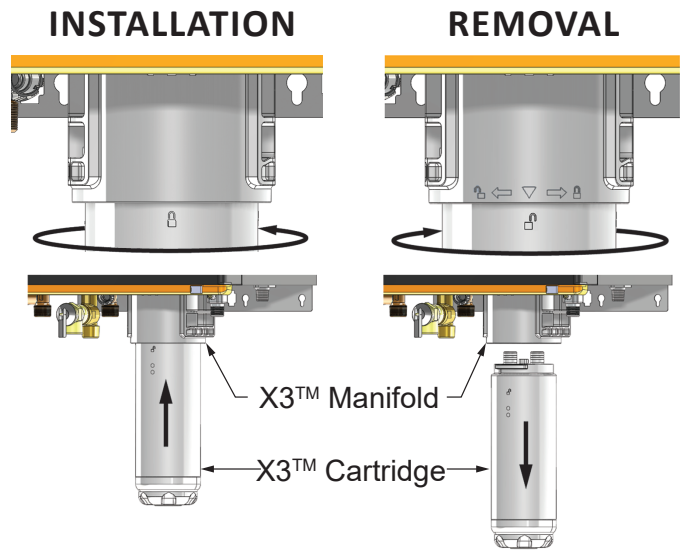

-Pressure relief valve-

The water heater has a high-temperature shutoff switch built in as a standard safety feature (called a Hi-Limit switch) therefore a “**pressure only**” relief valve is required.

- An approved pressure relief valve is supplied with your water heater and must be installed on the outlet connection.
- The discharge piping for the pressure relief valve must be directed so that the hot water cannot splash outward and cause damage or personal injury.
- Attach the discharge tube to the pressure relief valve and run the end of the tube to within 6 in (152 mm) from the floor. This discharge tube must allow free and complete drainage without any restrictions.
- If the pressure relief valve discharges periodically, this may be due to thermal expansion in a closed water supply system. Contact the water supplier or a local plumbing professional on how to correct this situation. Do not plug the pressure relief valve.
- The pressure relief valve must be manually operated periodically to check for correct operation. Before operating the valve manually, check that it will discharge in a place for secure disposal.
- No valve must be placed between the relief valve and the water heater.

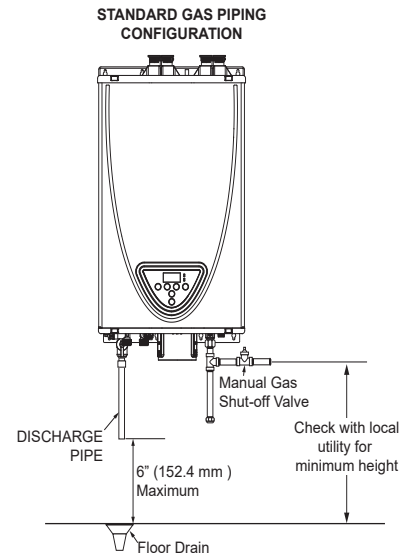

If another pressure relief valve is used or needs to be replaced, it must meet the following:

- The pressure relief valve must conform to ANSI Z21.22 or CAN 1-4.4 and installation must follow local codes.
- The discharge capacity must be at least 199,000 BTU/h for the 199X3P model, 180,000 BTU/h for the 180X3P model, 160,000 BTU/h for the 160X3P model,
- The pressure relief valve needs to be rated for a maximum of 150 psi (1 MPa).



WARNING

Hot water could be released. Before operating the pressure relief valve manually, check that it will discharge in a safe place. If water does not flow freely from the end of the discharge pipe, turn the gas supply and power OFF and call a qualified person to determine the cause. Refer to the pressure relief valve manufacturer's instructions for inspection and maintenance requirements.

Step 13: Condensate drain

- An accessory Neutralizer assembly (100112159/TH-NT01) is sold separately. (Refer to p. 11.)
- In the absence of applicable local codes and regulations, the manufacturer recommends that condensate be disposed of into a drain. Connect a drain tube from the condensate drain port (shown below) located on the bottom of the water heater to a standard drain.

NOTICE

- Follow all code requirements of the local authority on condensate neutralizers and whether or not they are required for the installation.
- Discharge condensate (acidic water) in accordance with all local codes and common safety practices.
- Use corrosion resistant pipe, such as PVC, for the condensate drain line. Do not use metal pipe.
- The condensate drain does not require a trap.
- Maintain a downward slope on the drain line(s), including installations in which the drain is not directly below the water heater.
- A field-supplied bypass is required if a neutralizer is installed.
- Do not connect the condensate drain line directly to a condensate pump.
- If the drain line is required to have bends, ensure that there are no kinks that will restrict the flow of condensation.

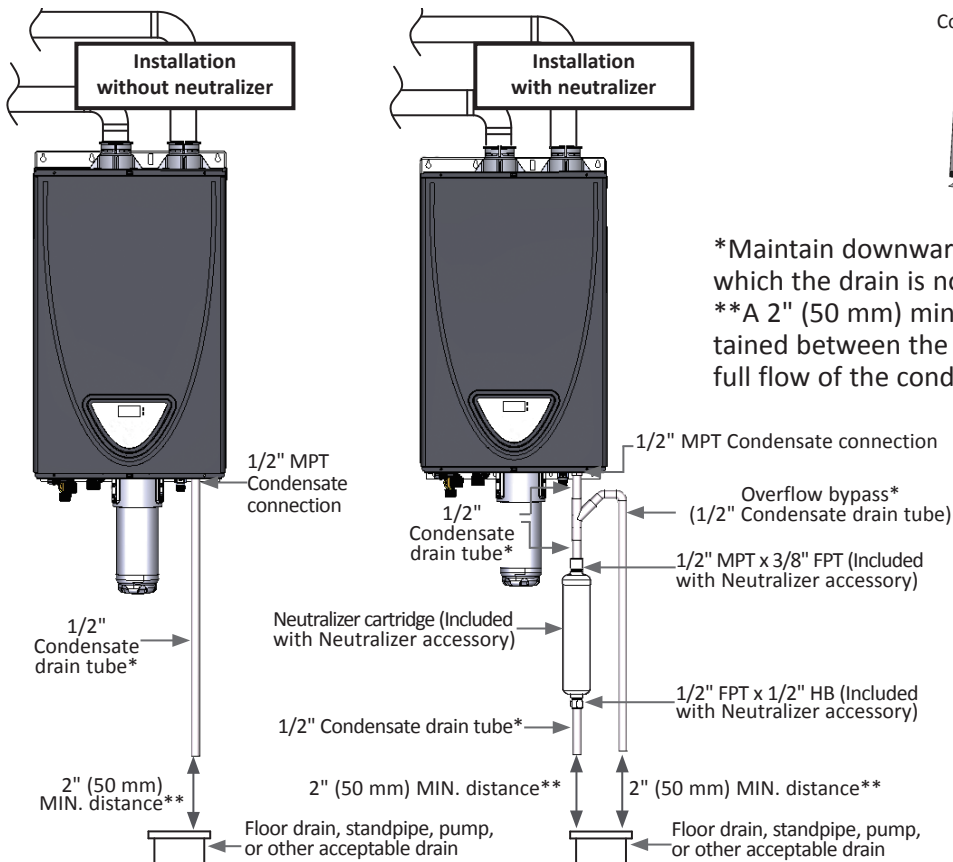

Condensate drain port

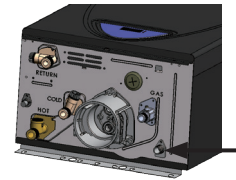

- *Maintain downward slope, including installations in which the drain is not directly below the heater.
- **A 2" (50 mm) minimum distance must be maintained between the condensate line and drain to allow full flow of the condensation.

Note: Refer to p. 43 regarding of the discharge of the pressure relief valve.

- The condensate drain is at atmospheric pressure (non-pressurized) and therefore must be allowed to drain freely with gravity only. Ensure that the condensate drain tube is not plugged or blocked, and ensure that it slopes downward to allow condensate to flow freely. **All portions of the condensate drain (neutralizer and drain tube) must be at a lower elevation than the water heater to prevent condensate water from building up inside the heat exchanger.**
- Condensate cannot be effectively neutralized if the neutralizer elements have been completely consumed. If this happens, condensate will remain acidic and can possibly cause damage to items such as pipes, concrete, etc., if drained improperly.
- The actual life of the neutralizer may vary, depending on the application and usage. Replace the cartridge when the condensate pH goes below 6.0.
- Please ensure that the cartridge is properly replaced before the neutralizer elements have been completely consumed.
- All preventative measures and safety practices must be adhered to when draining condensate. The manufacturer will not be responsible for any damage caused by condensate.
- A drain pan, or other means of protection against water damage, is recommended to be installed under the water heater in case of leaks.

Step 14: Electrical connections



WARNING

- Follow the electrical code requirements of the local authority having jurisdiction. In the absence of such requirements, follow the current edition of the National Electrical Code ANSI/NFPA 70 in the U.S. or the current edition of CSA C22.1 Canadian Electrical Code Part 1 in Canada.
- When servicing or replacing parts within the water heater, label all wires prior to disconnection to facilitate an easy and error-free reconnection. Wiring errors can cause improper and dangerous operation. Verify proper operation after servicing.
- Failure to observe these warnings could result in personal injury or death.

1. The water heater must be electrically grounded. Do not attach the ground wire to either the gas or the water piping.
2. The water heater requires a 120 VAC, 60 Hz electrical power supply that is properly grounded.
 - A proper disconnect (i.e. on/off switch, power plug, etc.) controlling the main power to the water heater must be provided for service reasons. (Must comply with local codes.)
 - Connect the power supply to the water heater exactly as shown in the wiring diagram.
3. The water heater can be hardwired or wired to a plug-in.
4. The use of a surge protector is recommended in order to protect the unit from power surges.

Indoor model

1. The water heater should be plugged into a 120VAC, 60 HZ electrical outlet.

Outdoor model

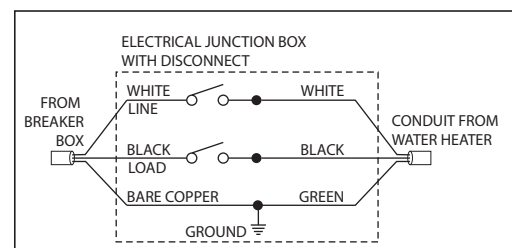
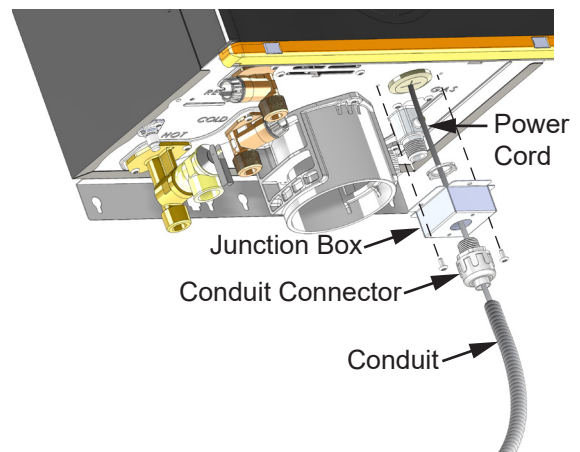
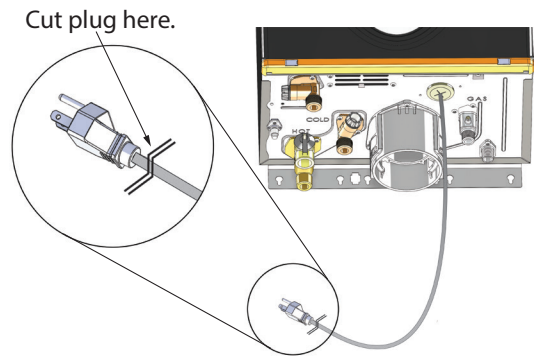

1. Remove the front cover.
2. Cut the plug off the power cord, see the figure to the right for reference. **NOTE:** Allow enough cord to make a connection to an approved weather proof electrical junction box.
3. Before proceeding verify that all power to the electrical junction box is off.
4. Measure and cut a section of liquid tight conduit. Install ½” liquid tight fittings on each end. **NOTE:** The conduit and conduit connections must be liquid tight and rated for the installed environment. Follow all local codes or in the absence of local codes, with the National Electrical Codes: ANSI/NFPA 70 in the USA or CSA standard C22.1 Canadian Electrical Code Part 1 in Canada.
5. Connect one end of the conduit section to the provided junction box. Route the power cord through the junction box and conduit and secure the junction box to the bottom of the water heater. See figure to the right for reference.
6. Connect other ½” conduit fitting to an approved weather proof electrical junction box. **NOTE:** insert the power cord into the electrical junction box first.
7. Make the electrical connections at the approved weather proof electrical junction box.
8. Verify all electrical connections and conduit connections are secure.
9. Replace the front cover and turn on power to the water heater.
10. Follow the instructions in the Getting Started section of this manual.



Step 15: Temperature remote controller (100276687/TM-RE43)

- The remote control is an optional accessory that can be installed remotely, to allow for temperature adjustment without having to go to the heater.
- When installed, the remote will take priority over the built-in controller of indoor models.

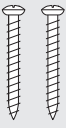
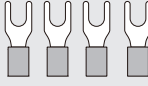
Verify that the items listed below are included with the remote controller.

Temperature remote controller	Screws	Fork terminals	Manual
 Qty: 1	 Qty: 2	 Qty: 4	 Qty: 1

-Installation-



WARNING

- **This remote controller is NOT waterproof.**
- **The water heater can only have one remote controller.**
- Do not install in high temperature environments, high humidity conditions, outdoors, in direct sunlight, or within the reach of children.
- Make sure the remote controller does not come into contact with water or other fluids.
- Failure to observe these warnings could result in personal injury or electrical shock.

NOTICE

- Do not place the remote controller cable close to other wires from other products.
- Cables used for the remote controller connection must be:
 - Minimum 20 gauge wire (No polarity)
 - Maximum 400 ft (122 m) long

Mounting and Wiring the Remote Controller

1. Take the **Frame** off of the remote controller with a flat head screwdriver. (Fig. A and B)
2. Attach the **Metal plate** on the wall with two provided screws. (Fig. B)
3. If you use another cable, crimp the **Fork terminals** to the wires. (Fig. C)

Fig. A



Fig. B

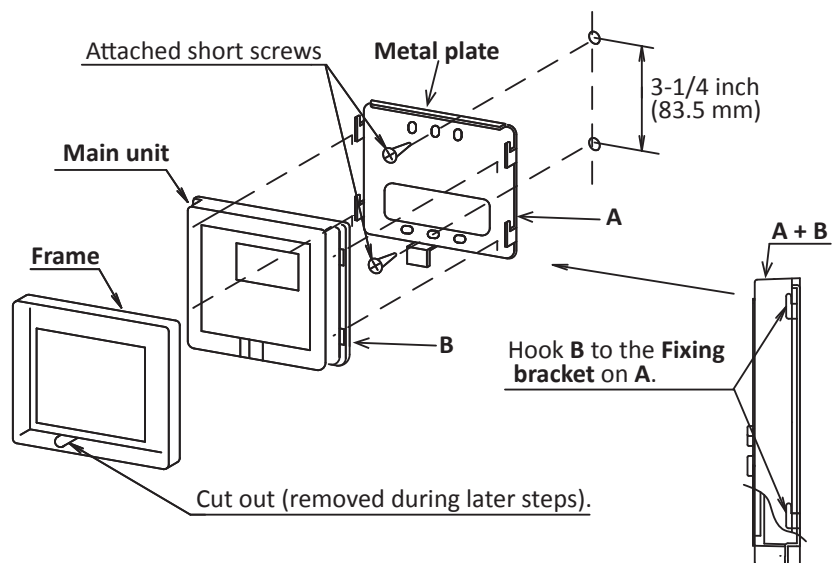
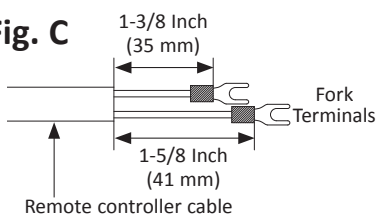

Fig. C





4. Open the **Plastic cover** and tighten the two **Fork terminals** beneath the two **Remote controller terminal** screws on the back of the **Main unit** (Fig. D-1). Cut out the inlet for the cable from the bottom of the main unit (Fig. D-2). Insert the cable through the inlet.
5. Close the **Plastic cover** and then hook the **Main unit** to the **Fixing bracket** on the **Metal plate**. (Fig. B)
6. Attach the **Frame** back onto the remote.

Fig. D-1

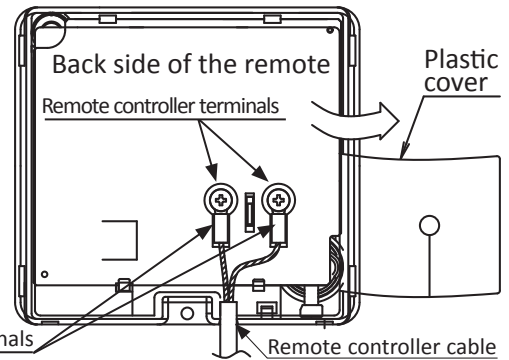
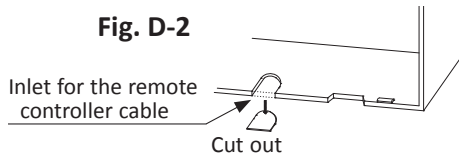
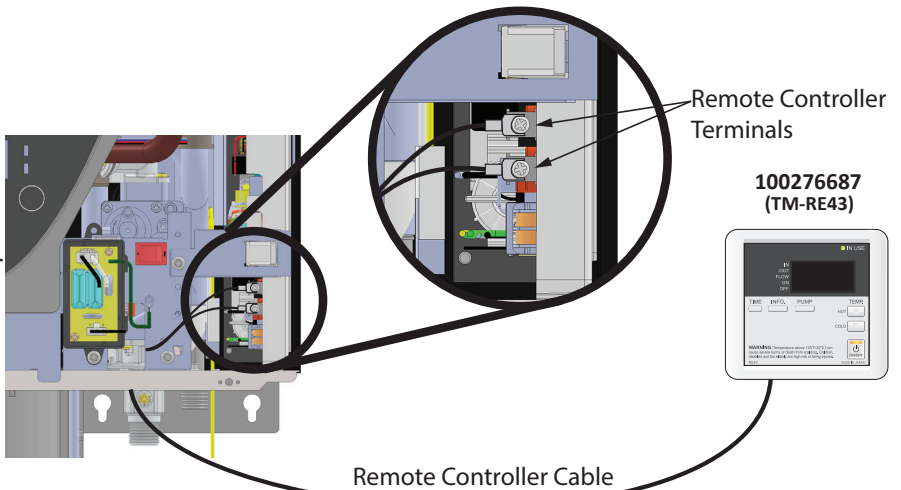

Fig. D-2



Connecting the remote controller to the water heater

1. Disconnect power supply from the water heater.
2. Take off the water heater's front cover.
3. Locate the remote controller terminals on the PCB. See the diagrams below.
4. Take off the back plate from the remote controller, and then attach the two fork terminals to connector base on the backside of the remote controller with two screws. Make sure the terminals are firmly fixed. (See the above instructions for installation of the remote controller.)
5. Insert the remote controller cable through the hole* with power cord coming out at the bottom of the water heater's casing and pass it behind the surge box.
6. Properly attach the remote controller cable to the remote controller terminal on the computer board with the screws (No polarity). **Do NOT jump or short-circuit the cable, or the computer will be damaged.**
7. Replace the front cover.
8. Reconnect power supply to the water heater.



*For outdoor installation

Insert the remote controller cable through the slit with a small cut shown in the figure below and pass it behind the built-in controller operational panel.

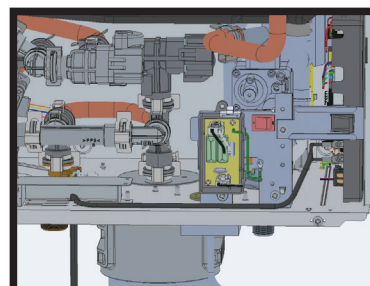
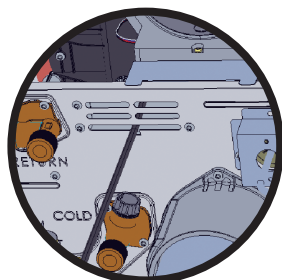

Step 16: High altitude settings



WARNING

- The maximum certified or allowable installed altitude is 10,100 ft (3,078 m).
- To adjust high altitude settings, adjust only the No. 2, No. 3, and No. 4 DIP switches in the MIDDLE bank of DIP switches. (See below.) **DO NOT** adjust the other DIP switches.
- Turn off the power supply to the water heater before changing the DIP switch settings.
- Failure to observe these warnings could lead to carbon monoxide poisoning or death.

Change the DIP switch

1. Turn off the power supply to the water heater.
2. After removing the front cover, remove the screw to pull out the PCB.
3. Change the DIP switches referring to the table below for each corresponding altitude. Do not adjust other DIP switches.
4. Put back the PCB into the unit and attach the removed screw and reinstall the front cover.

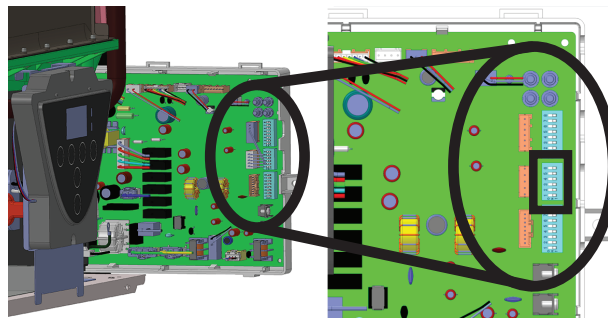

Check the elevation where your water heater is installed. Set DIP switches shown in the table below depending on the altitude.

Altitude	0 to 2,000 ft (0 to 610 m) (DEFAULT)	2,000 to 3,000 ft (611 to 914 m)	3,000 to 5,000 ft (915 to 1,524 m)	5,000 to 7,500 ft (1,525 to 2,286 m)	7,500 to 10,100 ft (2,287 to 3,078 m)
Middle bank of DIP switches	<p>No. 2 : OFF No. 3 : OFF No. 4 : OFF</p>	<p>No. 2 : OFF No. 3 : ON No. 4 : OFF</p>	<p>No. 2 : OFF No. 3 : OFF No. 4 : ON</p>	<p>No. 2 : OFF No. 3 : ON No. 4 : ON</p>	<p>No. 2 : ON No. 3 : ON No. 4 : ON</p>

NOTE: The dark squares indicate the correct DIP switch positions.

Step 17: Freeze protection system



- To set pump operation for freeze protection, adjust only the No. 4 DIP switch in the UPPER bank of DIP switches. (See below.) DO NOT adjust the other DIP switches.
- Turn off the power supply to the water heater before changing the DIP switch settings.
- Failure to observe these warnings could lead to carbon monoxide poisoning, severe personal injury, or death.

- There are two systems for freeze protection in the water heater—**heating block system** and **recirculation system** with the integrated pump.
 - This water heater comes equipped with heating blocks to protect the unit against damages associated with freezing. When the freeze protection thermostat senses air temperature below 36.5°F (2.5°C), the blocks will heat up to prevent freezing of the unit.
 - This water heater can recirculate the water in the pipes installed in the recirculation system with the integrated pump to prevent freezing. When the integrated thermistors detect water temperature below 50°F (10°C), the pump will activate and recirculate the water in the recirculation line. Use only with the Recirculation with Dedicated Line mode.*
- To operate these freeze protection systems, there has to be electrical power to the unit. Damage to the heat exchanger caused by freezing temperatures due to power loss is not covered under the warranty. In cases where power losses can occur, consider the use of a backup power supply.
- In any areas subject to freezing temperatures, the manufacturer highly recommends an indoor installation.
- The manufacturer also highly recommends the use of a backflow preventer (sold separately) to minimize the amount of cold air entering through the exhaust venting when the water heater is off.
- It is the installer's and owner's responsibility to be aware of freezing issues and take all preventative measures. The manufacturer will not be responsible for any damage to the heat exchanger as a result of freezing.
- If you will not be using your heater for a long period of time:
 1. Completely drain the water out of the unit. Refer to p. 69.
 2. Disconnect power to your heater.

This will keep your unit from freezing and being damaged.

NOTICE

The freeze protection system does not protect the X3™ Cartridge. Refer to the manufacturer for freeze protection options for the X3™ Cartridge.

*Recirculation system for freeze protection is only activated when the built-in/remote controller is off. When the integrated thermistors detect the water temperature above 52°F (11°C) over five minutes, the operation is deactivated. Pump operation for freeze protection is deactivated from the factory. If you want to activate the recirculation system for freeze protection, change the DIP switch setting below.

Change the DIP switch

1. Turn off the power supply to the water heater.
2. After removing the front cover, remove the screw to pull out the PCB.
3. Change the DIP switches referring to the table for each setting.
4. Put back the PCB into the unit and attach the removed screw and reinstall the front cover.

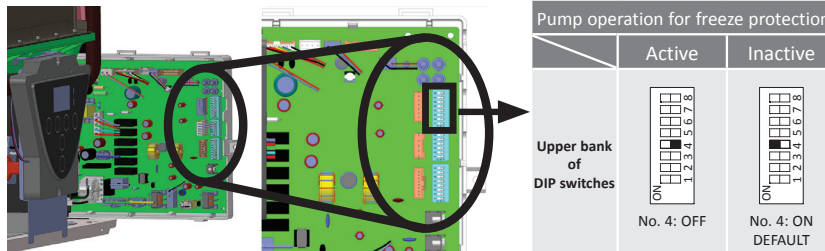

NOTICE

Only pipes within the water heater are protected by the freeze protection system. Any water pipes (hot or cold) located outside the unit will not be protected. Properly protect and insulate these pipes from freezing.

Step 18: Easy-Link System

The Easy Link system manages multiple water heaters to provide a set water temperature based on demand/flow rate. The water heater can be connected to the same or a specified model in an Easy-Link System as shown in the table below.

- The built-in Easy-Link System allows up to 2 units (160X3P and 180X3P) or 4 units (199X3P) to manifold together. The table below shows the allowable combinations.
- The supplied communication cable (100076516) is required for linking.
- An Easy-Link system will have full modulation from 9,000 btu/h to the sum of maximum inputs of the connected water heaters
- The priority heater is the heater that will be the first to activate when there is a call for demand. The pump of the priority heater will be the one in operation during recirculation pump active periods. The priority heater will rotate to the next number assigned heater based on either 12 hours of heater operation time or 100 start/stop cycles, whichever comes first.
- In the Easy-Link System, one unit must be designated as a **PARENT** unit by changing the Parent/Child DIP switch. Refer to the procedure below. The other unit(s) are **CHILD** units.



Type of unit	Model			Allocated No. from controller
PARENT	160X3P	180X3P	199X3P	1
CHILD	160X3P	180X3P	199X3P or 540	2,3,4*
Max. Number of child units	1	1	3	

*Each CHILD unit is allocated the above number from controller, which indicates on the display of the controller on the unit. (Refer to p. 73.)

Change DIP switch setting



WARNING

- To change the DIP switch settings for the Easy-Link System, locate the MIDDLE bank of DIP switches at the near side of the computer board of the PARENT unit.
- DO NOT adjust any other DIP switches .
- Turn off the power supply to the water heater before changing the DIP switch.
- Failure to observe this warning could result in carbon monoxide poisoning or death.

1. Turn off the power supply to the water heater.
2. After removing the front cover, remove the screw to pull out the PCB.
3. Only change the **No.1 DIP switch** of the middle bank of the **parent** unit to the ON position. (Refer to the figure on p. 51.)
4. Put back the PCB into the unit and attach the removed screw and reinstall the front cover.

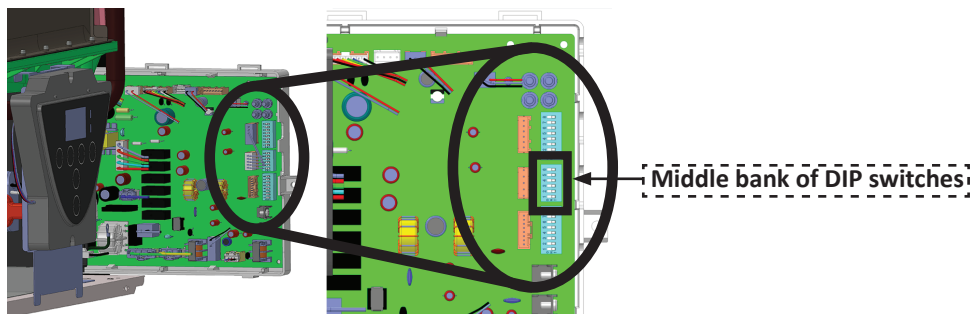

NOTICE

- If you connect more child units than allowed in the above table, surplus units will not operate within the Easy Link System.
- The set temperature for the system can only be adjusted by the Parent heater.
- If the option remote is installed, it must be installed on the Parent heater. The remote will set the temperature for all heaters.
- Only one remote can be connected to a water heater.

-Easy-Link connection procedures-

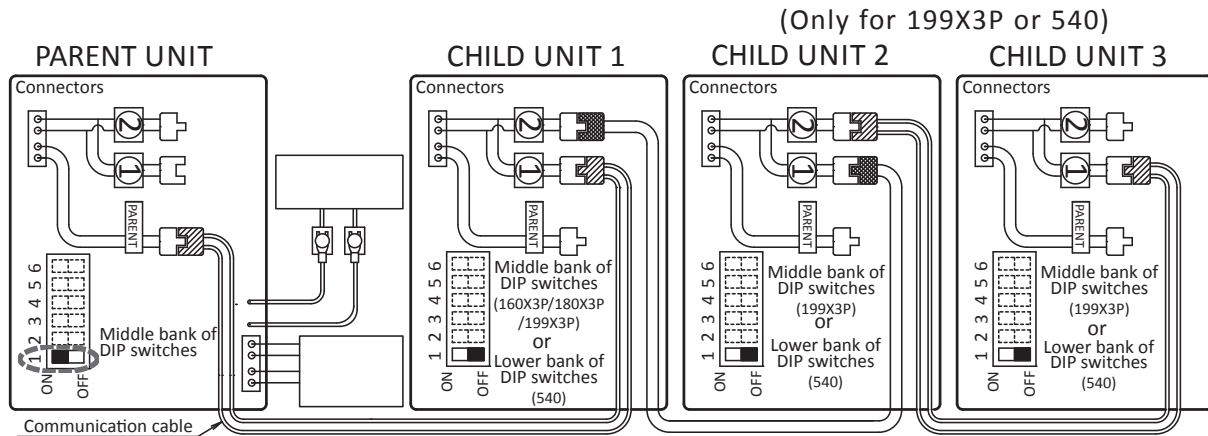

- The dark squares indicate the correct position of the DIP switch.

1. Make sure the power to the heaters are off.
 2. If an optional remote controller is used, it must be connected to the “PARENT” unit. The remote will set the temperature for the entire system. When the 160X3P/180X3P/199X3P model is the “PARENT” unit, the only controller that can be used is the **100276687 (TM-RE43)**.
 3. Select a 160X3P/180X3P/199X3P unit to be the “PARENT” unit. The “PARENT” unit should be one of the end units.
 4. On the “PARENT” unit, locate the three banks of DIP switches at the near side of the computer board. Change DIP switch No. 1 on the middle bank of DIP switches to the ON position. See the instructions of Change the DIP switch as shown in the previous page. Do not change any DIP switches on any of the “CHILD” units.
 5. Connect the “PARENT” connector of the “PARENT” unit to the “1” connector of the “CHILD-1” unit using the supplied communication cable.
- Steps 6 and 7 only apply to the 199X3P
6. Connect “2” connector of “CHILD-1” unit to the “1” connector of “CHILD-2” unit.
 7. Connect “2” connector of “CHILD-2” unit to the “1” connector of “CHILD-3” unit.
 8. Verify that all cables are connected as shown in the diagram above.
 9. A: Turn on power to “PARENT” and wait for the (remote and/or built-in) controller to display “1”.
 B: Turn on power to “CHILD-1” and wait for the (remote and/or built-in) controller to display the assigned #.
 C: Turn on power to “CHILD-2” (If installed) and wait for the (remote and/or built-in) controller to display the assigned #.
 D: Turn on power to “CHILD-3” (If installed) and wait for the (remote and/or built-in) controller to display the assigned #.

The numbering system automatically allocates the unit number to each **CHILD** water heater in the Easy-Link System, in accordance with the table on p. 50.

GETTING STARTED





FOR YOUR SAFETY, READ BEFORE OPERATING

- Check the **GAS and WATER CONNECTIONS** for leaks before firing unit for the first time.
- Open the main gas supply valve to the unit using only your hand to avoid any spark. Never use tools. If the knob will not turn by hand, do not try to force it; call a qualified service technician. Forced repair may result in a fire or explosion due to gas leaks.
- Be sure to check for the presence of leaking gas toward the bottom of the unit because some gases are heavier than air and may settle towards the floor.
- Check the **GAS PRESSURE**. Refer to p. 31.
- Do not try to light the burner manually. It is equipped with an electronic ignition device which automatically lights the burner.
- Check for **PROPER VENTING and COMBUSTIBLE AIR** to the water heater.
- **Purge the GAS and WATER LINES** to remove any air pockets.
- Do not use this appliance if any part has been under water. Immediately contact a qualified installer or service agency to replace a flooded water heater. Do not attempt to repair the unit! It must be replaced!



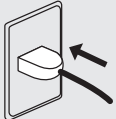

IF YOU SMELL GAS:

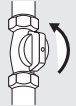
- Do not try to start the water heater.
- Do not touch any electric switches; do not use any phone in your building.
- Immediately call your gas supplier from a neighbor's phone. Follow the gas supplier's instructions.
- If you cannot reach your gas supplier, call the fire department.
- Failure to observe these warnings could lead to fire or an explosion, resulting in severe injury or death.

		<i>Initial Operation</i>
1.	Turn on the 120 VAC, 60 Hz power supply to the water heater.	
2.	If standby light is on, turn it off by pressing ON/OFF button on temperature controller.	
3.	Open a hot water tap to verify that water is flowing to that tap, then close the hot water tap.	
4.	Clean filters of any debris. Refer to p. 68 for instructions.	
5.	Open the manual gas valve.	

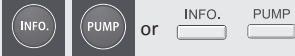
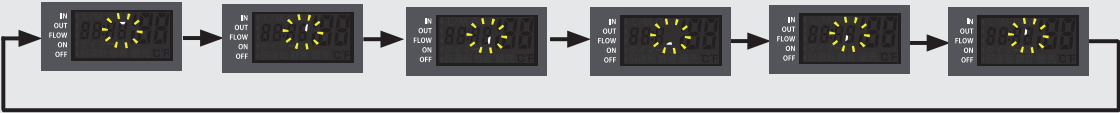
GETTING STARTED

		<i>Initial Operation (cont.)</i>	
6.	<p>Steps 6-8 are only for standard recirculation installations. Go to step 9 for applications using the cross over valve or when the pump will not be used. Start pump operation test by built-in controller or remote controller. If your water heater is installed outdoors without the optional remote controller, remove the front cover to operate the built-in controller after removing the four screws when operation on the controller is required.</p>		
	<p>Press the ON/OFF button on the controller so the STAND BY LED turns off.</p>		
	<p>Press and hold "INFO." and "PUMP" simultaneously for at least three seconds, then the integrated pump starts operation for five minutes.*</p>		
	<p>A segment of the zero is lighting as follows in clockwise order during pump operation test.</p>		
7.	<p>During the pump operation test, open and close a faucet in the loop several times to relieve air in the pipe. If air is stuck in the pump, it can cause pump failure or decreased water flow.</p>		
8.	<p>Check recirculation water flow. Refer to p. 65. Make sure the flow rate is approx. 2 to 3 GPM. If the flow rate is less than 2 GPM, there is a possibility that air is stuck in the pump. Open and close the faucet again to relieve air.</p>		<p>Water flow (EX.: 3.0GPM)</p>

*In an Easy-Link System, each integrated pump does the initial test run in order for five minutes.

GETTING STARTED

	<i>Initial Operation (cont.)</i>
9.	After finishing the pump operation test, complete the following procedures. (Refer to pp. 58 to 62): <ul style="list-style-type: none">• Set outlet water temperature• Setting the time• Pump operation timers• Setting pump timers• Selecting a pump timers

FOR YOUR SAFETY READ BEFORE OPERATING

WARNING: If you do not follow these instructions exactly, a fire or explosion may result causing property damage, personal injury or loss of life.

A. This appliance does not have a pilot. It is equipped with an ignition device which automatically lights the burner. Do not try to light the burner by hand.

B. BEFORE OPERATING smell all around the appliance area for gas. Be sure to smell next to the floor because some gas is heavier than air and will settle on the floor.

WHAT TO DO IF YOU SMELL GAS

- Do not try to light any appliance.
- Do not touch any electric switch; do not use any phone in your building.
- Immediately call your gas supplier from a neighbor's phone. Follow the gas supplier's instructions.
- If you cannot reach your gas supplier, call the fire department.

C. Use only your hand to turn the gas shutoff valve. Never use tools. If the valve will not turn by hand, don't try to repair it, call a qualified service technician. Force or attempted repair may result in a fire or explosion.

D. Do not use this appliance if any part has been under water. Immediately contact a qualified installer or service agency to replace a flooded water heater. Do not attempt to repair the unit! It must be replaced!

OPERATING INSTRUCTIONS

1. STOP! Read the safety information above on this label.
2. Turn off all electric power to the appliance.
3. Do not attempt to light the burner by hand.
4. Turn the gas shutoff valve located on the outside of the unit to the closed position.
5. Wait five (5) minutes to clear out any gas. If you then smell gas, STOP! Follow "B" in the safety information above on this label. If you don't smell gas, go to the next step.
6. Turn the gas shutoff valve located on the outside of the unit to the open position.
7. Turn on all electrical power to the appliance.
8. If the appliance will not operate, follow the instructions in "To Turn Off Gas to Appliance," and call your service technician or gas supplier.

TO TURN OFF GAS TO APPLIANCE

1. Turn off all electric power to the appliance if service is to be performed.
2. Turn the gas shutoff valve located on the outside of the unit to the closed position.

OPERATING SAFETY

⚠ DANGER

⚠ Vapors from flammable liquids will explode and catch fire causing death or severe burns.
Do not use or store flammable products such as gasoline, solvents or adhesives in the same room or area near the water heater.



Keep flammable products:

1. Far away from heater.
2. In approved containers.
3. Tightly closed and
4. Out of reach of children.

Vapors:

1. Cannot be seen.
2. Are heavier than air.
3. Go a long way on the floor.
4. Can be carried from other rooms to the main burner by air currents.

Water heater has a main burner, which may come on at any time and will ignite flammable vapors.

Installation: Do not install water heater where flammable products will be stored or used unless the main burner is at least 18" (457 mm) above the floor. This will reduce, but not eliminate the risk of vapors being ignited by the main burner.

Read and follow water heater warnings and instructions. If the owner's manual is missing, contact the retailer or manufacturer.

⚠ DANGER

1. Water temperature over 125°F (52°C) can cause severe burns instantly or death from scalds.
2. Children, disabled and elderly are at highest risk of being scalded.
3. Feel water before bathing or showering.
4. Temperature limiting valves are available. See manual.
5. The outlet temperature of the water heater is set at 120°F (50°C). If you require water temperatures below this setting, follow the instruction manual.
6. Use this heater at your own risk. Test the water before bathing or showering. Do not leave children or an infirm person unsupervised. See your local water supply company [plumbing hardware retailer] for temperature limiting valves that are available.



A pressure relief valve listed as complying with the standard for Relief Valve and Automatic Gas Shutoff Devices for Hot Water Supply System, ANSI Z21.22 • CSA 4.4, shall be installed at the time of installation of the water heater in the location specified by the manufacturer. Local codes shall govern the installation of relief devices for safety operation of the water heater. The relief valve must not be removed or plugged.

No valve shall be placed between the relief valve and the water heater. The relief from the discharge of the pressure relief valve shall be disposed of in a suitable place where it will cause no damage. Also, there shall be no other reducing coupling or other restrictions installed on the discharge line to restrict flow.

See Installation Manual heading "PRESSURE RELIEF VALVES" for installation and maintenance of relief valve discharge line and other safety precautions.

Controller settings

The illustration below shows an example of the controllers. When it is installed outdoors without the optional remote controller, remove the front cover to operate the built-in controller if necessary. We would strongly recommend that the optional remote controller should be installed when it is installed outdoors.

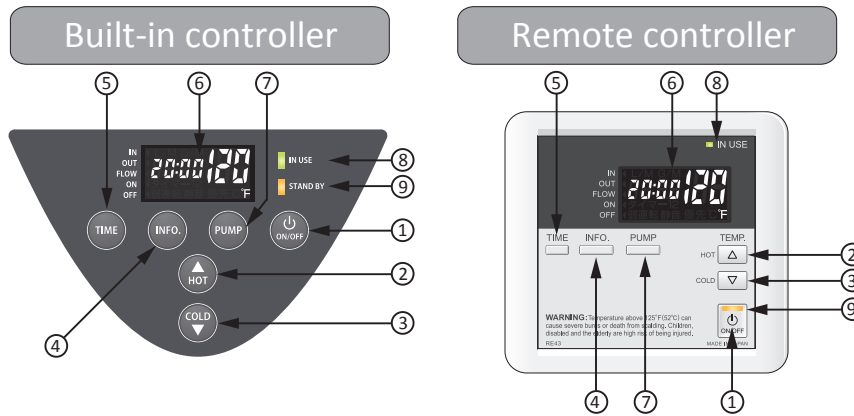

No.	Description	Note	No.	Description	Note
1	"ON/OFF" Button	Press this button to start or stop operation.	5	"TIME" Button	Press this button to set the current time.
2	"HOT" Button	Press the "HOT" button or the "COLD" button to set the outlet water temperature, the current time, and PUMP TIMER.	6	LCD	The current time, set temperature, error code and other information are displayed.
3	"COLD" Button		7	"PUMP" Button	Press this button to set and control the pump operation.
4	"INFO." Button	Press the "INFO" button to display: -Inlet/Outlet Water Temperature -Water Flow Rate -Pump Status/Settings	8	IN USE LED	The LED lights during combustion.
			9	STAND BY LED	The LED lights when power is on.

OPERATION

NOTICE

- When the remote controller is installed it will take priority over the built-in controller.
- The controller has an energy saving mode. Five minutes after the water heater stops operating, the backlight of the controller turns off.
- The backlight of the remote will turn back on once the water heater begins firing again.

WARNING **Temperatures above 125°F (52°C) can cause severe burns or death from scalding. Children, disabled and the elderly are at high risk of being injured.**









°F	120	125	130	135	140	145	150	155
°C	49	52	54	57	60	63	66	68
Time to produce serious burn	more than 5 min.	1½ to 2 min.	about 30 sec.	about 10 sec.	less than 5 sec.	less than 3 sec.	about 1½ sec.	about 1 sec.

NOTICE

- Flow rate to activate the water heater: 0.4 gallon per minute at the default set temperature (1.5 L/min.) Activation flow rate may be higher when the temperature rise is small. At 9,000 btu/h minimum input, there needs to be a minimum 45°F rise for 0.4 gpm activation.
- Flow rate to keep the water heater running: 0.26 gallon per minute (1.0 L/min.)

-Set outlet water temperature-

OPERATION

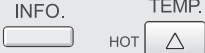







	Operation	Controllers	
		Built-in controller	Remote controller
1.	Turn on the 120 VAC power supply to the unit.		
2.	Press the "ON/OFF" button on the controller in order to turn the controller on.		
3.	When ON, the STAND BY LED is lit.		
4.	It shows the set temperature of output water on its display as shown in the picture on the right. (EX.: 120°F)	 (EX.: 120°F)	
	Press the "HOT" button or the "COLD" button to set the temperature setting of the unit.		
5.	 <p>Temperatures above 125°F (52°C) can cause severe burns or death from scalding. Children, disabled and the WARNING elderly are at high risk of being injured.</p> <p>Increasing temperature from 120°F (50°C) to 125°F (52°C) :</p> <ol style="list-style-type: none"> 1. The water heater must be in Stand By to increase the temperature. 2. Press the "HOT" button to set 120°F (50°C). 3. Press and hold the "INFO" button and the "HOT" button for at least 3 seconds. The remote will emit a beep and change to 125°F (52°C). 4. Press the "HOT" button to set up to 140°F (60°C). 		

Temperature Table of Controller

The following table lists the available temperature setting.
The factory temperature setting is 120°F (50°C)

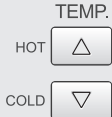
°F	100	105	110	115	120	125	130	135	140
°C	38	40	43	45	50	52	55	57	60

-Setting the time-

	Operation	Controllers	
		Built-in controller	Remote controller
1.	Turn on the 120 VAC power supply to the unit.		
2.	Press the "TIME" button on the controller in order to set the time. This operation is available regardless of ON/OFF setting of the controller.		
	The time in the display will flash.		
3.	Press the "HOT" button or "COLD" button to set the time. Press and hold the "HOT" or "COLD" button to adjust the time more quickly.		
	NOTICE: The time is displayed in twenty-four hour clock time. For example, 11:00 is 11:00 a.m. and 23:00 is 11:00 p.m.		
4.	Press the "TIME" button on the controller in order to save and exit.		
	When the remote is on, the current time and set temperature are displayed. When the remote is off, the display turns off.		

OPERATION

-Pump operation timers-

The built-in controller and remote offer two timer settings for the pump operation: PUMP TIMER 1 and TIMER 2. The default setting from the factory is for both PUMP TIMERS to be OFF.

The pump will only operate during the times set for PUMP TIMER 1 and PUMP TIMER 2. There are four options for pump timer operation.

- Both PUMP TIMER 1 and PUMP TIMER 2 are activated.
- Neither PUMP TIMER 1 nor PUMP TIMER 2 are activated. (The recirculation pump will never operate in this mode.)
- Only PUMP TIMER 1 is activated.
- Only PUMP TIMER 2 is activated.

NOTICE: Set the time for PUMP TIMER 1 and PUMP TIMER 2 before you select a pump timer option. Follow the steps in "Setting the time", then complete the steps in "Setting pump timers".

PUMP TIMERS 1 & 2 activated



NO PUMP TIMER activated





Only PUMP TIMER 1 activated

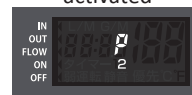

Only PUMP TIMER 2 activated









- Setting pump timers & operation -



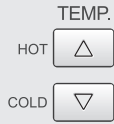



	Operation	Controllers	
		Built-in controller	Remote controller
1.	Turn on the 120 VAC power supply to the unit.		
2.	Press and hold the "PUMP" button on the controller for at least 3 seconds to enter the pump timer setting mode. This operation is available regardless of ON/OFF of the controller.		
	The ON time for PUMP TIMER 1 will flash, indicating that you can set the start time.		
3.	Press the "HOT" button or "COLD" button to select the time. Press and hold the "HOT" or "COLD" button to adjust the time more quickly.		
	NOTICE: The time is displayed in twenty-four hour clock time. For example, 11:00 is 11:00 a.m. and 23:00 is 11:00 p.m.		
4.	Press the "PUMP" button when the desired start time flashes on the display.		
	The OFF time for PUMP TIMER 1 will flash, indicating that you can set the end time.		
5.	Press the "HOT" button or "COLD" button to select the time. Press and hold the "HOT" or "COLD" button to adjust the time more quickly.		
	NOTICE: The time is displayed in twenty-four hour clock time. For example, 11:00 is 11:00 a.m. and 23:00 is 11:00 p.m.		
6.	Press the "PUMP" button when the desired end time flashes on the display.		
	The ON time for PUMP TIMER 2 will flash, indicating that you can set the start time.		

	Operation	Controllers																		
		Built-in controller	Remote controller																	
7.	<p>Press the "HOT" button or "COLD" button to select the time. Press and hold the "HOT" or "COLD" button to adjust the time more quickly.</p> <p>NOTICE: The time is displayed in twenty-four hour clock time. For example, 11:00 is 11:00 a.m. and 23:00 is 11:00 p.m.</p>																			
8.	<p>Press the "PUMP" button when the desired start time flashes on the display.</p>																			
	<p>The OFF time for PUMP TIMER 2 will flash, indicating that you can set the end time.</p>																			
9.	<p>Press the "HOT" button or "COLD" button to select the time. Press and hold the "HOT" or "COLD" button to adjust the time more quickly.</p> <p>NOTICE: The time is displayed in twenty-four hour clock time. For example, 11:00 is 11:00 a.m. and 23:00 is 11:00 p.m.</p>																			
10.	<p>Press the "PUMP" button when the desired end time flashes on the display.</p>																			
11.	<p>The following steps will set the temperature drop that must occur before the recirculation pump will activate.</p>																			
	<table border="1"> <thead> <tr> <th>Temperature drop below set temp. at which pump turns on</th> <th>°F</th> <th>-10</th> <th>-15</th> <th>-20*</th> <th>-25</th> <th>-30</th> <th>-35</th> <th>-40</th> </tr> </thead> <tbody> <tr> <td></td> <th>°C</th> <td>-6</td> <td>-8</td> <td>-11</td> <td>-14</td> <td>-17</td> <td>-19</td> <td>-22</td> </tr> </tbody> </table> <p>*The value has been preset at the factory. (Default)</p>	Temperature drop below set temp. at which pump turns on	°F	-10	-15	-20*	-25	-30	-35	-40		°C	-6	-8	-11	-14	-17	-19	-22	
Temperature drop below set temp. at which pump turns on	°F	-10	-15	-20*	-25	-30	-35	-40												
	°C	-6	-8	-11	-14	-17	-19	-22												
	<p>Press the "HOT" button or the "COLD" button to select the temperature at which the pump will activate.</p>																			
12.	<p>Press the "PUMP" button on the controller to save your settings.</p>																			

OPERATION

	Operation	Controllers																			
		Built-in controller	Remote controller																		
13.	<p>The following steps will set the temperature drop that must occur before the recirculation pump will turn off.</p> <table border="1"> <tr> <td>Temperature drop below set temp. at which pump turns off</td> <td>°F</td> <td>-5*</td> <td>-10</td> <td>-15</td> <td>-20</td> <td>-25</td> <td>-30</td> <td>-35</td> </tr> <tr> <td></td> <td>°C</td> <td>-3</td> <td>-6</td> <td>-8</td> <td>-11</td> <td>-14</td> <td>-17</td> <td>-19</td> </tr> </table> <p>*Preset at the factory. (Default)</p>	Temperature drop below set temp. at which pump turns off	°F	-5*	-10	-15	-20	-25	-30	-35		°C	-3	-6	-8	-11	-14	-17	-19		
	Temperature drop below set temp. at which pump turns off	°F	-5*	-10	-15	-20	-25	-30	-35												
	°C	-3	-6	-8	-11	-14	-17	-19													
	<p>Press the "HOT" button or the "COLD" button to select the temperature at which the pump will turn off.</p>																				
14.	<p>Press the "PUMP" button on the controller to save your settings.</p>																				
	<p>When the controller is on, the current time and set temperature in the display turns on. When the controller is off, the display turns off.</p>																				

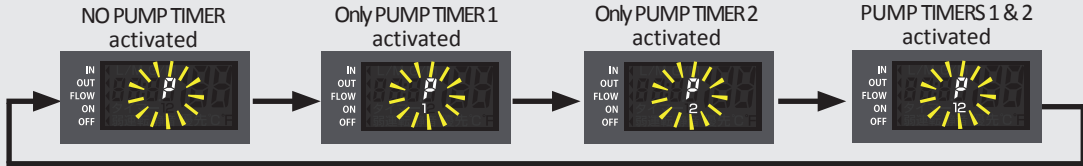
- Selecting a pump timer-

	Operation	Controllers	
		Built-in controller	Remote controller
1.	<p>Both PUMP TIMERS have a default setting of OFF from the factory. Press the "PUMP" button on the controller to set the mode. (The options are shown in step 3.) This operation is available regardless of the ON/OFF status of the controller.</p>		
2.	<p>The current status of the PUMP TIMER will flash for 10 seconds. During this time, you can change the mode. Otherwise, the mode will remain unchanged.</p>		
3.	<p>Press the "PUMP" button on the controller in order to change the option. The order of the option is as follows.</p>		
			
4.	<p>Press the "INFO" button on the controller in order to save your setting.</p>		







-Display example-

The display on the controller indicates which PUMP TIMER is set by displaying a number below the time: 1, 2, or 12. (12 indicates PUMP TIMER 1 and PUMP TIMER 2.)

The arrow to the right of ON or OFF indicates the current status of the PUMP TIMER(s). If the current time falls within the time range set for a PUMP TIMER, the arrow will point toward ON. (The timer is ON.)

If the current time falls outside the time range set for a PUMP TIMER, the arrow will point toward OFF. (The timer is OFF.)

See below for examples of each scenario. In each scenario below, PUMP TIMER 1 is set to activate at 6:00 AM (6:00) and deactivate at 9:00 AM (9:00). PUMP TIMER 2 is set to activate at 6:00 PM (18:00) and deactivate at 9:00 PM (21:00).

	Examples	Controllers	
		Built-in controller	Remote controller
1.	The display shows that PUMP TIMER 1 is in operation. The current time falls within the time range that is set for PUMP TIMER 1. Current time: 8:00 AM (8:00) Set temperature of output water: 120 °F PUMP TIMER 1: SET PUMP TIMER 2: OFF		
2.	The display shows that PUMP TIMER 1 is NOT in operation. The current time falls outside the time range that is set for PUMP TIMER 1. Current time: 10:00 AM (10:00) Set temperature of output water: 120 °F PUMP TIMER 1: SET PUMP TIMER 2: OFF		
3.	The display shows that PUMP TIMER 2 is in operation. The current time falls within the time range that is set for PUMP TIMER 2. Current time: 8:00 PM (20:00) Set temperature of output water: 120 °F PUMP TIMER 1: OFF PUMP TIMER 2: SET		
4.	The display shows that PUMP TIMER 2 is NOT in operation. The current time falls outside the time range that is set for PUMP TIMER 2. Current time: 10:00 PM (22:00) Set temperature of output water: 120 °F PUMP TIMER 1: OFF PUMP TIMER 2: SET		
5.	The display shows that PUMP TIMER 1 and PUMP TIMER 2 are set, and one of them is in operation. In this example, PUMP TIMER 1 is running because it is set to activate between 6:00 AM and 9:00 AM. (See above.) Current time: 7:00 AM (7:00) Set temperature of output water: 120 °F PUMP TIMER 1: SET PUMP TIMER 2: SET		
6.	The display shows that PUMP TIMER 1 and PUMP TIMER 2 are set, and none of them is in operation. The current time falls outside the time ranges that are set for PUMP TIMER 1 and PUMP TIMER 2. Current time: 10:00 AM (10:00) Set temperature of output water: 120 °F PUMP TIMER 1: SET PUMP TIMER 2: SET		





OPERATION

-On-Demand Pump Operation-

The On-Demand pump operation complies with California's Title 24. This operation runs the pump and fires the water heater each time the "PUMP" button on the heater's built-in controller or optional remote controller is pushed. The pump runs until water temperature at the return thermistor inside the water heater reaches 102°F (38.9°C) or the water temperature at the thermistor rises 10°F (5.6°C) above the initial temperature of the water. The pump will automatically stop after 5 minutes if still in operation. Number 5 DIP switch of the lower bank needs to be changed to "ON" position in the operation.

Note: The pump timer is not available when the No. 5 DIP switch of the lower bank is set to "ON".

OPERATION

	Operation	Controllers	
		Built-in controller	Remote controller
1.	Press the "PUMP" button to start pump operation and fire the water heater.		
2.	"P" and the set temperature are indicated (on the right) during Manual pump operation.		
3.	The pump will stop automatically in five minutes and the current set temperature and time will be displayed on the screen.		



WARNING

- For manual pump operation, adjust only the No. 5 DIP switch in the LOWER bank of DIP switches. (See below.) DO NOT adjust the other DIP switches.
- Turn off the power supply to the water heater before changing the DIP switch settings.
- Failure to observe these warnings could lead to carbon monoxide poisoning or death.

Change the DIP switch

1. Turn off the power supply to the water heater.
2. After removing the front cover, remove the screw as shown in the following to pull out the PCB.
3. Change the DIP switches referring to the table for each setting.
4. Put back the PCB into the unit and attach the removed screw and reinstall the front cover.

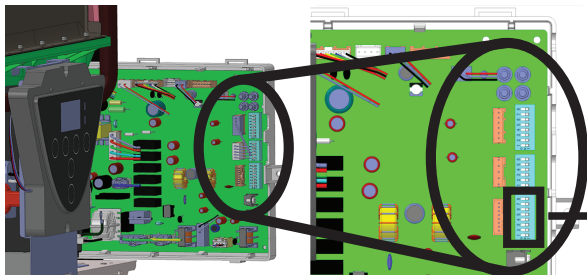



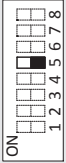
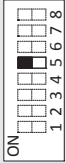



Set DIP switch shown in the table below.

Manual pump operation		
Lower bank of DIP switches		
	No. 5 : OFF DEFAULT	No. 5 : ON

-Information mode-









You can get some information about the water heater condition by pressing the "INFO" button. For more information, follow the procedures below:

	Operation	Controllers	
		Built-in controller	Remote controller
1.	Press the "INFO" button on the controller to enter the information mode.		INFO. 
2.	Press the "INFO" button to display the inlet water temperature.		Inlet water temperature (EX.: 60°F)
3.	Press the "INFO" button again to display the outlet water temperature.		Outlet water temperature (EX.: 120°F)
4.	Press the "INFO" button again to display the water flow.		Water flow (EX.: 3.5 GPM)
5.	Press the "INFO" button to exit the information mode.		INFO. 

OPERATION

-Unit of measure conversion-

Units of measure can be changed from Imperial to Metric and vice versa. For example, temperature can be changed from °F to °C. Flow rate will also change from gallons per minute to liters per minute when this setting is changed. Follow this procedure to change this setting:

	Operation	Controllers	
		Built-in controller	Remote controller
1.	Press the "ON/OFF" button on the controller in order to turn the controller on.		
2.	When ON, the STAND BY LED is lit.		
3.	The current set temperature and time will be displayed on the screen.		(EX.: 120°F)
4.	Press the "INFO" buttons for at least 3 seconds.		INFO. 
5.	The set temperature should now be displayed in the alternate unit of measurement.		(EX.: 50°C)

NOTICE When installed on an indoor heater, the 100276687 (TM-RE43) has priority for set temperature over the built-in controller.

PCB settings

-SETTING THE TEMPERATURE ON THE PCB- (WITHOUT BUILT-IN CONTROLLER or REMOTE CONTROLLER)



WARNING

- To set the temperature, adjust only the No. 5 DIP switch in the MIDDLE bank of DIP switches. (See below.) **DO NOT** adjust the other DIP switches.
- Turn off the power supply to the water heater before changing the DIP switch settings.
- Failure to observe these warnings could lead to carbon monoxide poisoning, severe personal injury, or death.

There are two preset temperatures (120°F (50°C) and 140°F (60°C)) that you can select when the temperature controller is inoperable. To do so, adjust the appropriate DIP switch as shown in the table below. When the remote controller is in normal operation, the set temperature of the remote controller is given priority over the set temperature of the DIP switch settings.

Change the DIP switch

1. Turn off the power supply to the water heater.
2. After removing the front cover, remove the screw to pull out the PCB.
3. Only change the DIP switch referring to the table for each setting.
4. Put back the PCB into the unit and attach the removed screw and reinstall the front cover.

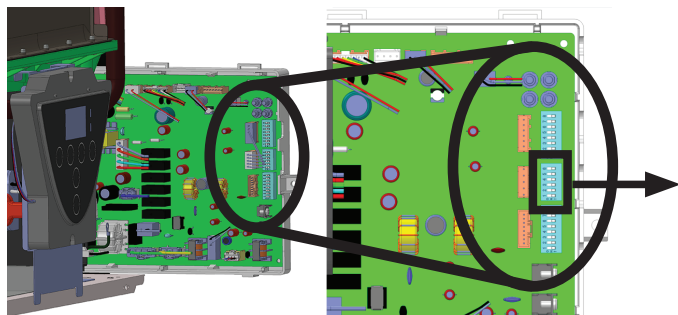

The factory temperature setting is to 120 °F (50 °C).

Outlet temperature setting	120°F (50°C) DEFAULT	140°F (60°C)
Middle bank of DIP switches		
	No.5 : OFF	No.5 : ON

NOTE: Only change the switches with dark squares. The dark square indicates the correct DIP switch positions.

MAINTENANCE AND SERVICE

-Regular maintenance-



WARNING

- Turn off the electrical power supply and close the manual gas shutoff valve and the manual water control valve before servicing.
- Failure to do so could result in severe personal injury, or death.

- Clean the cold-water/return inlet filters. (Refer to the Unit Draining and Filter Cleaning Section on p. 68.)
- The intake and exhaust venting **MUST** clear of any blockages. Remove any blockage.
- The intake and venting system should be checked annually for any leaks, corrosion, blockages, or damage. Replace any damaged section of venting and clear any blockage.
- The burner should be checked annually for dust, lint, grease or dirt.
- Keep the area around the water heater clear. Remove any combustible materials, gasoline or any flammable vapors and liquids.
- If the relief valve discharges periodically, it may be due to thermal expansion in a closed water supply system. Contact the water supplier or local plumbing inspector on how to correct this situation.
- The screen on the rain protection tray should be inspected annually and cleaned if needed.
- Visually check of burner flames (see below) through the burner window in the burner assembly located at the middle of the water heater.

Satisfactory

"Short and stable light blue flame with red hot spots on the knit burner"



Unsatisfactory due to air-rich

"Lifting blue flame from the knit burner and vibration noise sometimes occurs."

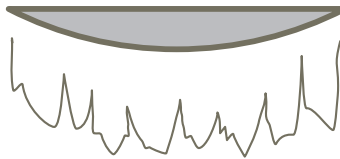

Unsatisfactory due to gas-rich

"Short lifting pale light blue flame with red flame from the knit burner"

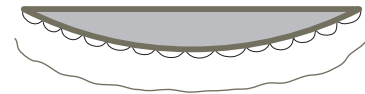

The manufacturer recommends having the unit checked once a year or as necessary by a licensed technician. If repairs are needed, any repairs should be done by a licensed technician.

MAINTENANCE

-Measuring inlet gas pressure-



WARNING

1. Turn off all electric power to the water heater if service is to be performed.
2. Turn the manual gas valve located on the outside of the unit to the off position.
3. Failure to follow these steps could lead to fire or explosion, resulting in personal injury or death.

The water heater cannot perform properly without sufficient inlet gas pressure. Below are instructions on how to check the inlet gas pressure. **THIS IS ONLY TO BE DONE BY A LICENSED PROFESSIONAL.**

1. Turn off all electric power to the water heater.
2. Shut off the manual gas valve on the gas supply line.
3. Remove the front cover and remove the screw as shown in the following to pull out the PCB. (Figure 1 on p. 68)

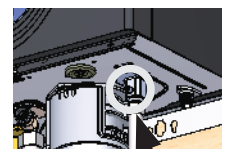

Pressure port

MAINTENANCE AND SERVICE

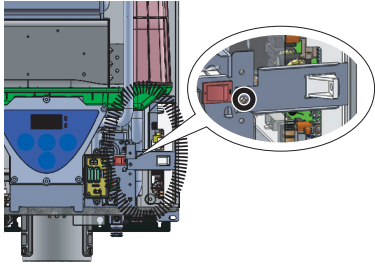

Figure 1

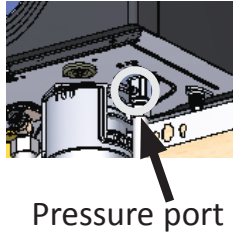

Figure 2

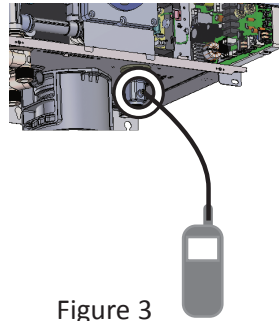

Figure 3

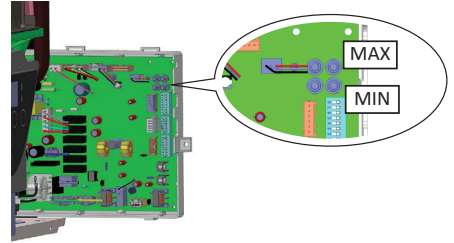
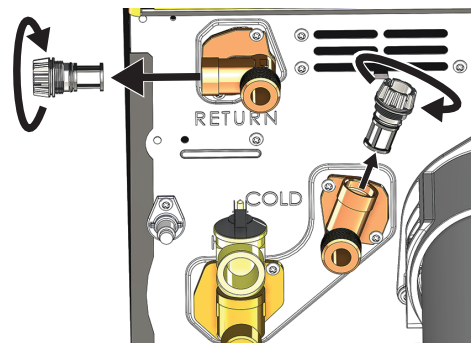

Figure 4

4. Remove the screw from the pressure port which is located on the gas inlet of the water heater. (Figure 2)
5. Connect the manometer to the pressure port and zero the manometer. (Figure 3)
6. Turn on the electric power to the water heater.
7. Re-open the manual gas valve. Verify that there are no gas leaks.
8. With all gas burning equipment off, take a reading of the static gas pressure and make a note of it.
9. Measure gas supply pressure at maximum heater operation: Open hot water faucets to create maximum flow. Press the MAX button on the computer board. (Figure 4) Take a reading of the supply dynamic gas pressure with all gas burning equipment running at maximum rate.
10. The static and dynamic pressures should be within the ranges specified on the heater's rating plate and the table on p. 31.
11. Measure gas supply pressure at minimum heater operation: Reduce water flow so the heater is running at minimal operation. Press the MIN button on the computer board. (Refer to the figure 4.) Take a supply gas pressure reading and verify that it is within the specified inlet gas pressure range.
12. Shut off all water fixtures.
13. Shut off the manual gas valve on the gas supply line.
14. Remove the manometer and reinstall the screw to the pressure port securely with no gas leaking.
15. Put back the PCB into the case and reinstall the screw to fix it.
16. Reinstall the front cover with the four screws.
17. Turn on the manual gas valve.

-Water filter cleaning-

1. Close the manual gas shutoff valve.
2. Turn off power to the unit and wait five (5) seconds. Turn on again.
3. Wait 30 seconds, and then turn off power to the unit.
4. Close the inlet water valve.
5. If the heater is part of an Easy-Link or Multi-Unit System, close the inlet and outlet water valves to isolate the heater. Then proceed to step 6.
6. Open all hot water taps in the house. When the residual water flow has ceased, close all hot water taps.
7. Have a bucket or pan to catch the water from the unit's drain plugs. If isolation valves are installed, open the drains to drain the water. If isolation valves are not installed, **unscrew** the filters and open the pressure relief valve to drain all the water out of the unit. Do not lose the o-rings that will be on the two filter caps.
8. Wait a few minutes to ensure all water has completely drained from the unit.
9. Clean the filter: Check the water filters located within the cold and return inlets. With a tiny brush, clean the water filter of any debris which may have accumulated and reinsert the filters.
10. Securely screw the drain filter plugs back into place. Hand-tighten only.





-Rain protection tray cleaning-

The rain protection tray has a screen to prevent lint or dust from entering into the water heater. Lint and dust built up on the screen can reduce the air supply for combustion. The screen should be inspected annually and cleaned if needed.

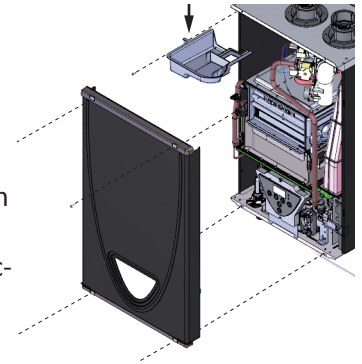
1. Shut off the manual gas valve on the gas supply line.
2. Shut off the power to the heater.
3. Remove the front cover and remove the screw of the upper left corner to detach the rain protection tray from water heater.
4. Remove the accumulated lint and dust from the screen and rinse the rain protection tray with clean water.
5. Dry the rain protection tray and screen.
6. Install the rain protection tray with the removed screw.
7. Install a front cover with the four screws.



-How to drain the unit for vacations or long periods of non-use-

1. Close the manual gas shutoff valve.
2. Turn off power to the unit and wait five (5) seconds. Turn on again.
3. Wait 30 seconds, and then turn off power to the unit.
4. Close the inlet water valve.
5. If the heater is part of an Easy-Link or Multi-Unit System, close the inlet and outlet water valves to isolate the heater. Then proceed to step 6.
6. Open all hot water taps in the house. When the residual water flow has ceased, close all hot water taps.
7. Have a bucket or pan to catch the water from the unit's drain plugs. If isolation valves are installed, open the drains to drain the water. If isolation valves are not installed, **unscrew** the filters and open the pressure relief valve to drain all the water out of the unit. Do not lose the o-rings that will be on the two filter caps.
8. Remove the small drain plug, item 469 on pp. 79 and 81, and drain.
9. **Drain the X3™ Cartridge:** Have a bucket or pan to catch water from the X3™ Cartridge. To remove the X3™ Cartridge, turn it left until the  symbol aligns with the  symbol. Pull down to remove it from the water heater. Drain the water in the X3™ Cartridge completely.
10. Wait a few minutes to ensure all water has completely drained from the unit.
11. Keep the cold, hot, return water valves closed. Keep the gas valve closed. Keep supply power disconnected.

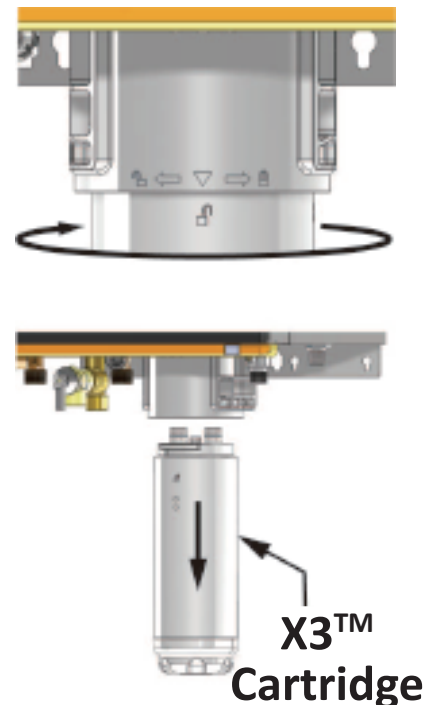

TROUBLE SHOOTING

	PROBLEM	SOLUTIONS
TEMPERATURE and AMOUNT OF HOT WATER	It takes a long time to get hot water at the fixtures.	<ul style="list-style-type: none"> • Check to see if a pump operation timer of recirculation is active. If not, it will take time for the hot water to get from the heater to the fixture. (pp. 59 to 62) • Check the recirculation pump for proper flow. (pp. 57 and 65) • The inlet filters on the return and inlet connections may need to be cleaned. (p. 68) • The screen on the rain protection tray may need to be cleaned. (p. 69) • The length of piping between the water heater and fixture determines the time it takes for the hot water to arrive.
	The water is not hot enough.	<ul style="list-style-type: none"> • Is the set temperature set too low? (pp. 58 and 66) • Is the gas supply valve open fully? (p. 52) • Compare the flow and temperature. See the charts on pp. 82 and 83. • Check cross plumbing between cold water lines and hot water lines.
	The water is too hot or hot water is not available when a fixture is opened or the hot water turns cold and stays cold. or fluctuation in hot water temperature.	<ul style="list-style-type: none"> • Is the set temperature set too high? (pp. 58 and 66) • Make sure the unit has 120 VAC, 60 Hz power supply. • If you are using the remote controller and/or built-in controller, is the standby light on? If not push the ON/OFF button on the controller to enable operation. • Is the water supply valve to the water heater open fully? • Are the filters on the cold water inlet and return connection clean? (p. 68) • Is the hot water fixture sufficiently open to draw at least 0.4 GPM (1.5 L/min) through the water heater? (pp. 57 and 65) • Check for cross connection between cold water lines and hot water lines. • Are the fixtures clean of debris and obstructions (such as the faucet aerator)? • Is the gas supply valve open fully? (p. 52) • Is there enough gas in the tank / cylinder? (For Propane model) • Is the screen on the rain protection tray clean? (p. 69) • If a Thermostatic Mixing Valve (TMV) is installed it may need to be inspected. Contact the TMV manufacturer's customer support.
WATER HEATER	The fan motor is still spinning after operation has stopped.	<ul style="list-style-type: none"> • This is normal. After operation has stopped, the fan motor keeps running from 15 to 70 seconds in order to re-ignite quickly, as well as purge all the exhaust gas out of the flue.
	Unit sounds abnormal while in operation.	<ul style="list-style-type: none"> • Contact the manufacturer at 1-877-737-2840 (USA). 1-888-479-8324 (Canada).
BUILT-IN/REMOTE CONTROLLER	Controller Display is blank.	<ul style="list-style-type: none"> • Make sure the unit is supplied with power. • Make sure the connection to the unit is correct. (pp. 46 and 47)
	An ERROR code is displayed.	<ul style="list-style-type: none"> • Please see pp. 73 to 75.

Error code

- The units have self-diagnostic functions for safety and convenience when troubleshooting.
- If there is a problem with the installation or the unit, the error code will be displayed on the built-in controller or remote controller.
- Consult the table on the following pages for the description of each error code.

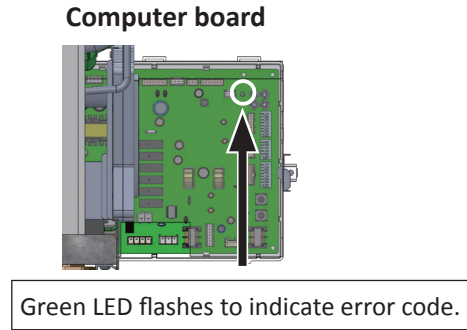
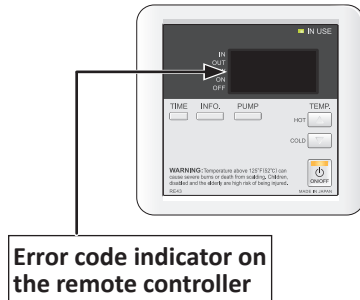
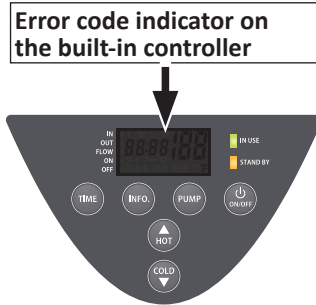

-Single unit Installation-

Example: If your unit has the “321” error code (which signifies an inlet thermistor failure)

- **Indicator on the built-in controller and/or remote controller:** “321” will be displayed on the screen.
- **Green LED on the computer board:** The green LED on the computer board will indicate this code with two flashes every 1/2 second. The pattern will repeat with a three second delay between patterns.



Error code	Green LED
321	

Error Indication

Error Code on the temperature controller	Green LED	
	The number of flashes	Flash pattern
031 201 701 711	One	
311 321 331 341 351 391 441	Two	
051 111 121 211	Three	
611 631 651 661	Four	
101 921 931 991	Five	
510 511 521 551 721	Six	

TROUBLE SHOOTING

-How error codes display in an Easy-Link System-

Error codes will be displayed differently with units installed in an Easy-Link System. It will show both the error code and which unit has the error code. Below is an example of how the error code of "321" is displayed in an Easy-Link System.

Example: Unit #2 with a "321" error code (inlet thermistor failure)

- **Indicator on the built-in controller and/or remote controller of Parent unit*:** "321" and "2" will alternately flash on the display.
- **Unit #2:** "321" will flash on the display.
- **Unit #3 and #4:** These units will not display anything, as the error code does not pertain to them.

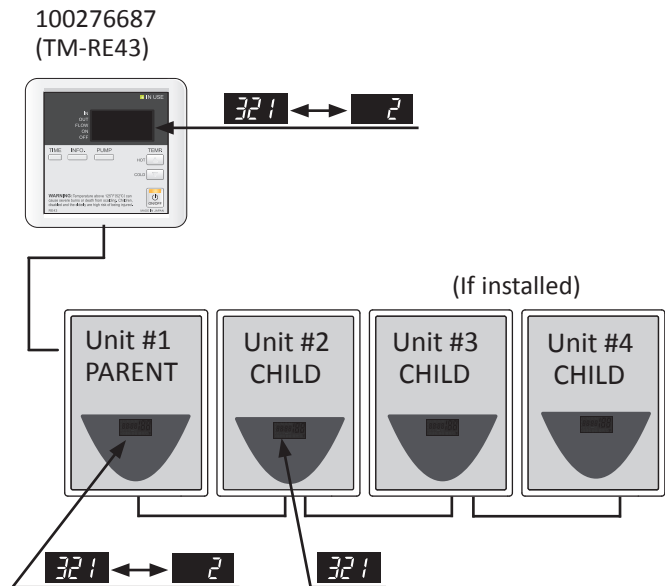
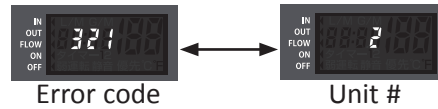

Fault analysis

The following list contains error codes, their descriptions, and items to check. If you are not qualified or comfortable performing any of the checks below, contact a qualified service agent or the manufacturer’s Technical Assistance Line. The phone number is located on the front cover of this manual.

Remote	Green LED	Malfunction description	Diagnosis
031	One Flash	Incorrect DIP switch setting	<ul style="list-style-type: none"> Check the DIP switch settings on the PCB (Part #701).
051	Three Flashes	Insufficient combustion air and gas	<ul style="list-style-type: none"> Check for dust and dirt on the air screen of the rain protection tray (Part #007) and verify air intake is not blocked. Check for connection/breakage of wires (Part #123, 715), burn marks on the computer board (Part #701).
101	Five Flashes	Combustion air and exhaust air blockage warning	<ul style="list-style-type: none"> See 991 Error Code.
111/121	Three Flashes	Ignition failure/ Loss of flame	<ul style="list-style-type: none"> Check if the Hi-limit switch (Part #412) is functioning properly. The switch has a button in its center, pressing the button will reset the switch. If tripped, you will hear and feel it click when resetting. If the high limit switch continues to trip contact a qualified service technician. Check for connection/breakage of wires, burn marks on the computer board (Part #701), and/or soot on the flame rod (Part #108). A “buzzing” ignition sound should be coming from the burner (Part #101) when the water heater prepares for combustion, if not heard then the igniter (Part #710) may be the issue. Listen for the “clunk” sound coming from gas solenoid valve assembly (Part #130) when water heater goes into combustion. If nothing is heard, then check the hi-limit switch (Part #412), overheat-cut-off fuse (Part #413) and connections to the gas valve Part #102). Check if there is water leaking from heat exchanger (Part #401) onto the flame and/or igniter rods (Part # 108, 109).
201	One Flash	Combustion air and gas line failure	<ul style="list-style-type: none"> Check if the Hi-limit switch (Part #412) is functioning properly. The switch has a button in its center, pressing the button will reset the switch. If tripped, you will hear and feel it click when resetting. If the high limit switch continues to trip contact a qualified service technician. Check if the fan motor (Part #103) is functioning properly. Check for connection/breakage of wires, burn marks on the computer board (Part #701).
211	Three Flashes	Pressure sensor failure	<ul style="list-style-type: none"> Check for connection/breakage of wires (Part #123, 715), burn marks on the computer board (Part #701).
311	Two Flashes	Heat exchanger thermistor failure	<ul style="list-style-type: none"> Check for connection/breakage of wires and/or debris on thermistor (Part #407, 408, 411, 715, 718, 731).
321	Two Flashes	Inlet thermistor failure	
331	Two Flashes	Outlet thermistor failure	
341	Two Flashes	Exhaust thermistor failure	
351	Two Flashes	Return Thermistor Failure	

TROUBLE SHOOTING

Fault analysis

Remote	Green LED	Malfunction description	Diagnosis
391	Two Flashes	Flame rod failure	<ul style="list-style-type: none"> Check for connection/breakage of wires (Part #709) and/or soot on the Flame rod (Part #108).
441	Two Flashes	Flow sensor failure	<ul style="list-style-type: none"> Check for connection/breakage of wires (Part #402, 715). Check for debris on the flow sensor impeller (Part #402). If a check valve(s) is installed in the water lines, verify that they are operating properly. The circulation lines may have more pressure drop than the pump is designed to push through. A Qualified Service Technician will need to perform a pressure drop calculation. If a cross over valve is installed, check if the DIP switch setting is correct. (Refer to pp. 40 and 41.)
511/510	Six Flashes	Abnormal main gas valve	<ul style="list-style-type: none"> Check for connection/breakage of the blue and brown wires going to gas valve assembly and/or burn marks on the computer board (Part #701).
521	Six Flashes	Air damper failure	<ul style="list-style-type: none"> Check if the air damper assembly (Part #122) is functioning properly. Check for connection/breakage of wires (Part #122, 715), burn marks on the computer board (Part #701).
551	Six Flashes	Abnormal gas solenoid valve	<ul style="list-style-type: none"> Check for connection/breakage of the blue, green, red, and light blue wires going to gas valve assembly above the heat exchanger and/or burn marks on the computer board (Part #701).
611	Four Flashes	Fan motor fault	<ul style="list-style-type: none"> Check for connection/breakage of wires, dust buildup in the fan motor (Part #103) and/or burn marks on the computer board (Part #701). Check for corrosion/damage of the wire connectors (Part #103). Inspect your exhaust air intake for any blockages, clear if any are found.
631	Four Flashes	Pump fault	<ul style="list-style-type: none"> Check for connection/breakage of wires in the pump (Part #726, 738). Check for reverse water flow through the pump. Install a check valve on the return line to the water heater.
651	Four Flashes	Flow adjustment valve fault	<ul style="list-style-type: none"> Inspect the flow adjustment valve (Part #402), for connection/breakage of wires Inspect the control valve for debris that may be blocking it.
661	Four Flashes	Bypass valve fault	<ul style="list-style-type: none"> Inspect the flow adjustment valve (Part #403), for connection/breakage of wires. Inspect the control valve for debris that may be blocking it.
701	One Flash	Computer board fault	<ul style="list-style-type: none"> Check for connection/breakage of wires or burn marks (Part #701, 714).
711	One Flash	Gas solenoid valve drive circuit failure	<ul style="list-style-type: none"> Refer to the 111 and 121 error codes.
721	Six Flashes	False flame detection	<ul style="list-style-type: none"> Check if there is water leaking from heat exchanger (Part #401) onto the flame and/or igniter rods (Part # 108, 109).
741	N/A	Communication error between water heater and remote controller	<ul style="list-style-type: none"> Verify the correct model/type of remote is installed. Inspect the connections between the water heater and remote controller. The code will appear if you disconnect the remote from the water heater without first turning off power to the water heater. Turn the water heater OFF then ON to reset.
751	N/A	Communication error between water heater and built-in controller	<ul style="list-style-type: none"> Inspect the connections between the water heater and built-in controller. The code will appear if you disconnect the remote from the water heater without first turning off power to the water heater. Turn the water heater OFF then ON to reset.

Remote	Green LED	Malfunction description	Diagnosis
761	N/A	Communication error in Easy-Link	<ul style="list-style-type: none"> • Check if the connections between the parent unit and the child units are correct. Refer to pp. 50 and 51. • Check the Child units for power. Troubleshoot any Child units without power. • The code will only appear on the Parent water heater if you disconnect an Easy Link wire from a Child water heater without first turning off power to the Easy Link System. Turn the Parent water heater OFF then ON to reset.
991	Five Flashes	Combustion air and exhaust air blockage	<ul style="list-style-type: none"> • Inspect the environment around the water heater. • Check the altitude/elevation of the area where the water heater is installed, and verify the DIP switches are set to the proper elevation. • Verify the vent length DIP switches match the equivalent vent length of the installed venting system. Refer to p. 16. • Inspect your exhaust air intake for any blockages, clear if any are found. • Check for dust and dirt on the air screen of the rain protection tray (Part #007) and verify air intake is not blocked. • Check for connection/breakage of wires and/or burn marks on the computer board (Part #701) • Check if the drain tube (Part #416) has drain in the tube and if so, discharge the drain. • Check for connection/breakage of wires (Part #123, 715), burn marks on the computer board (Part #701).

Component diagram

Case assembly

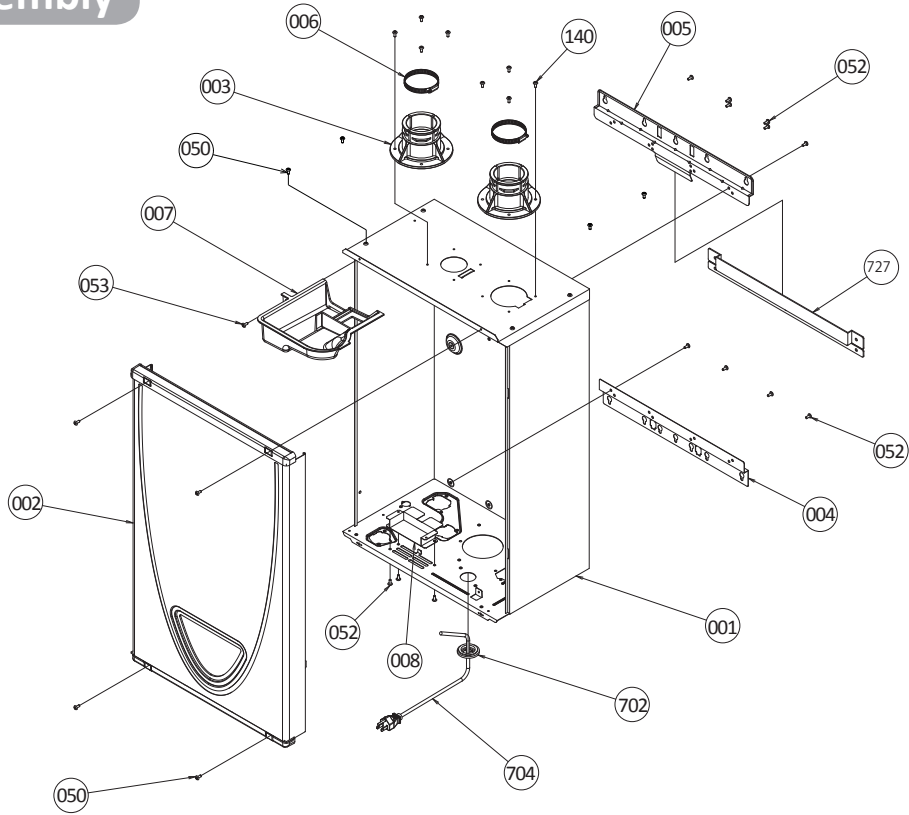

Built-in controller

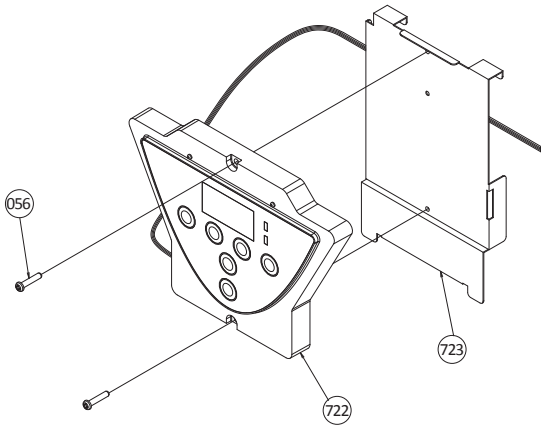

Surge box assembly

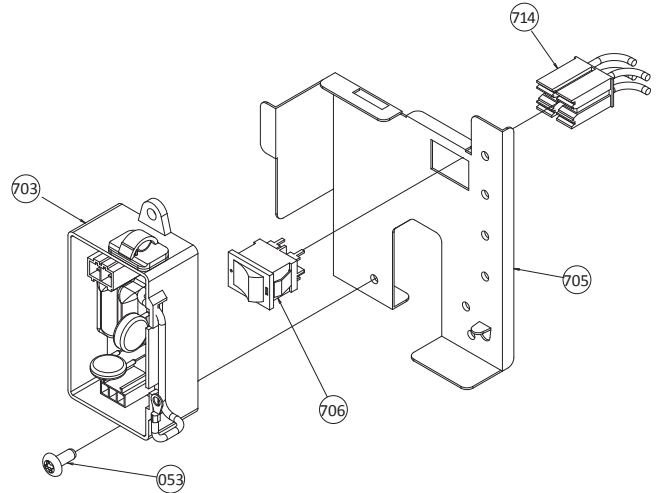

REPAIR PART

Computer board assembly

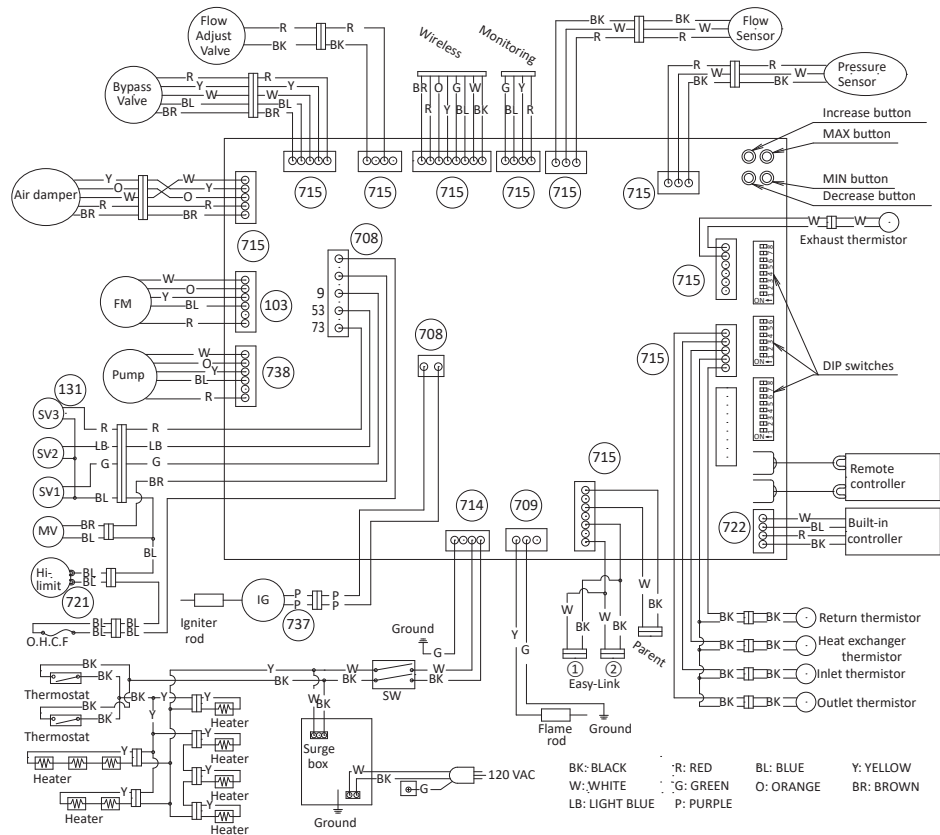
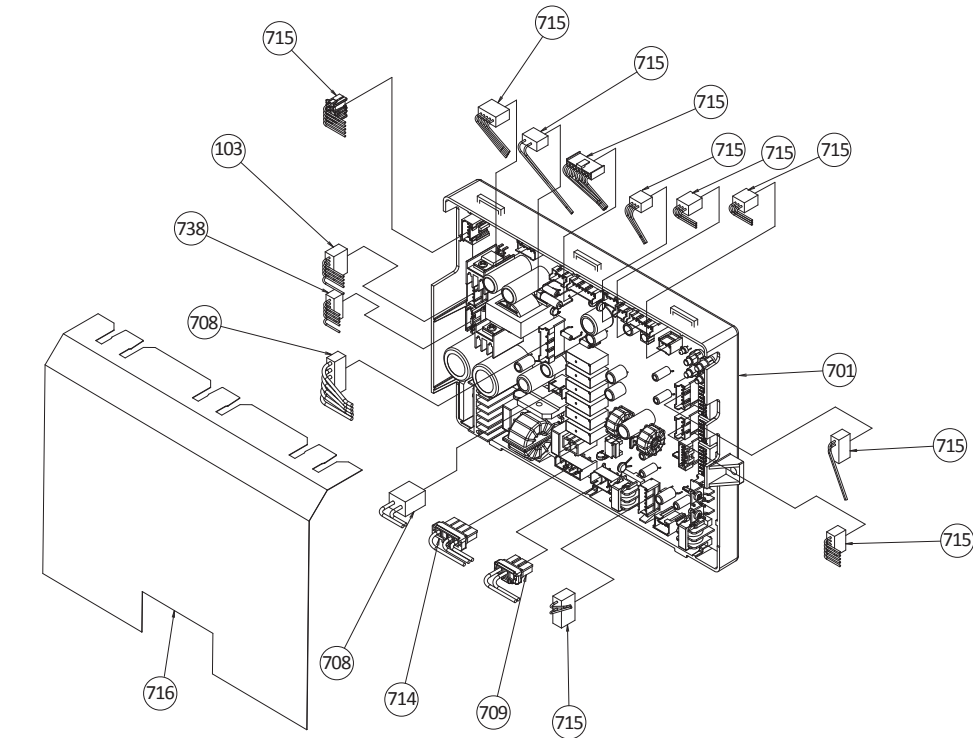

REPAIR PART

Gas line

Fan motor assembly

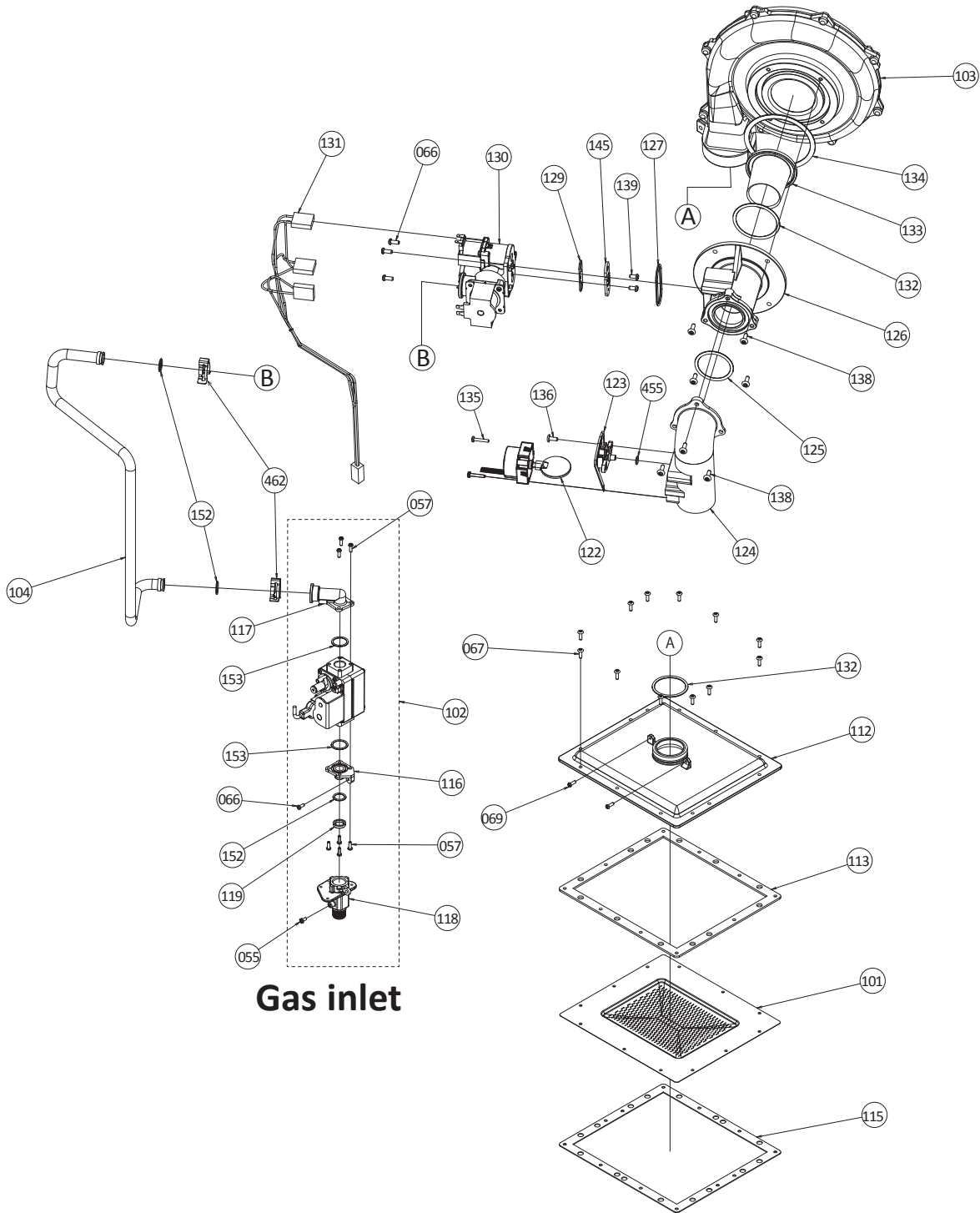

Burner assembly

Water way 1

Hi-limit switch

Heat exchanger

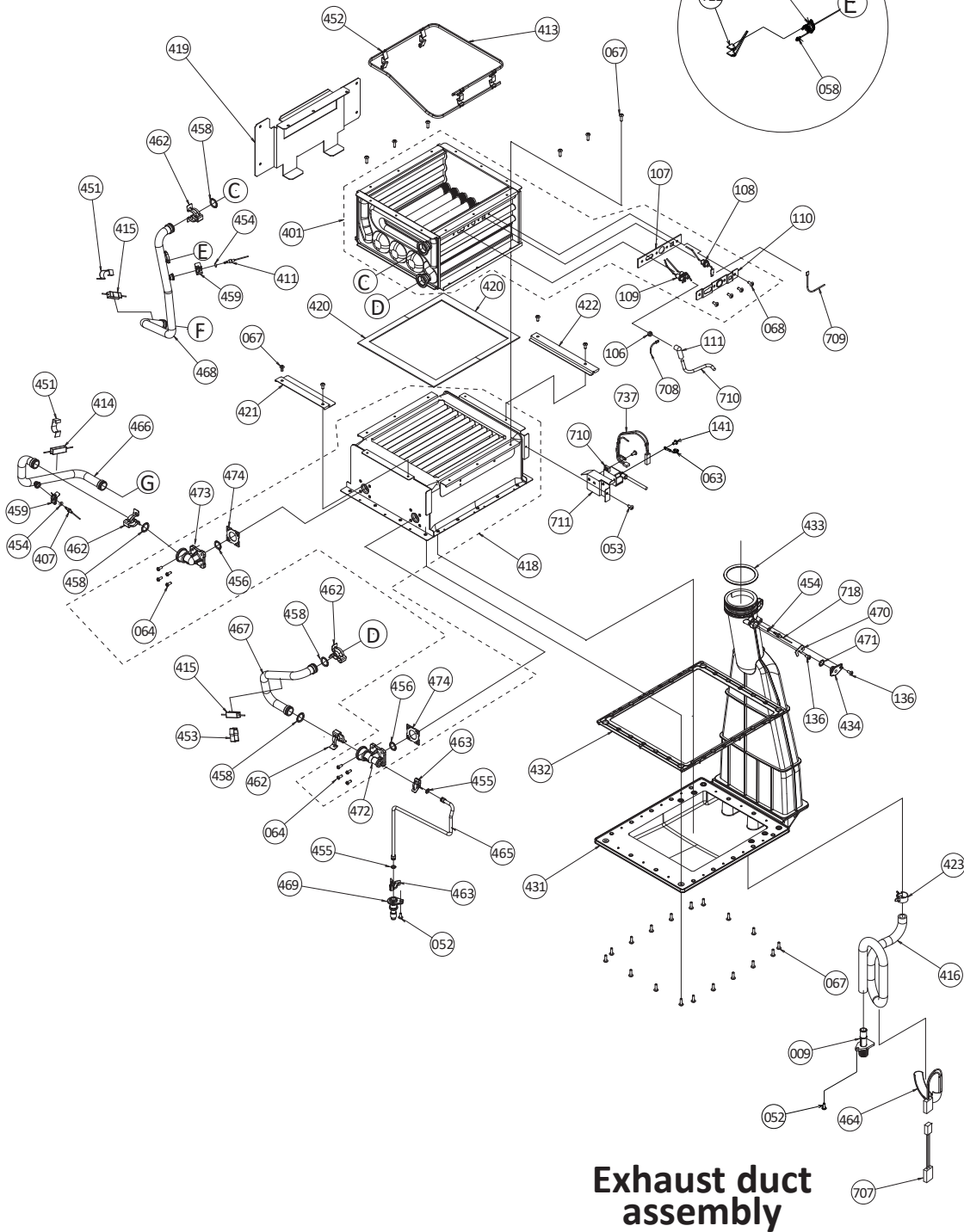

REPAIR PART

Water way 2

Pump & return inlet

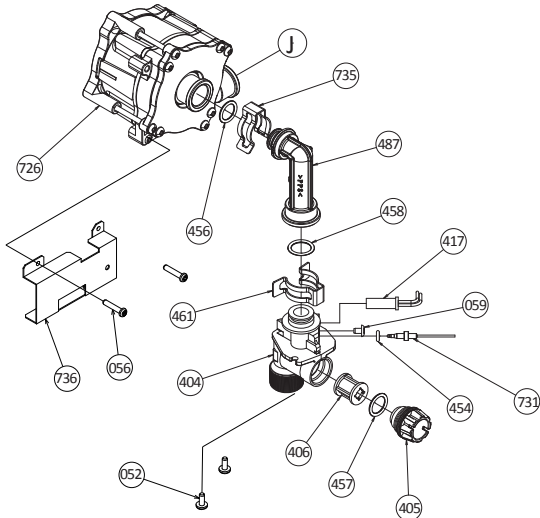

Bypass valve

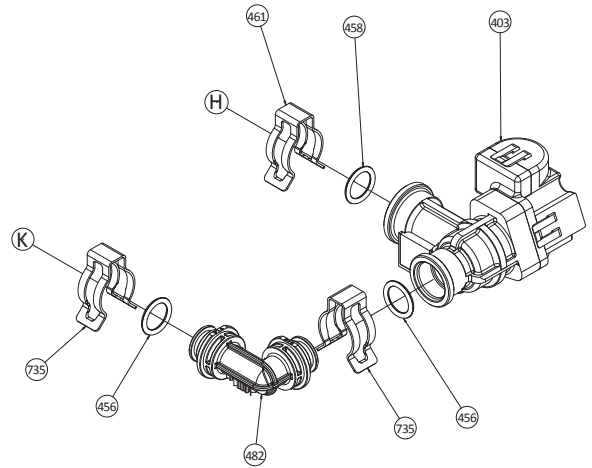

Water outlet

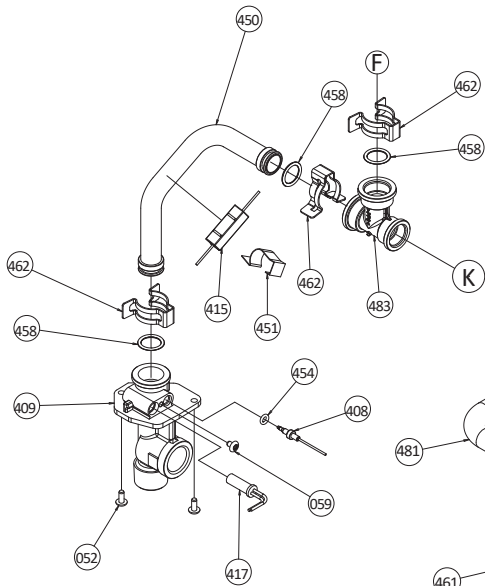

X3™ connection

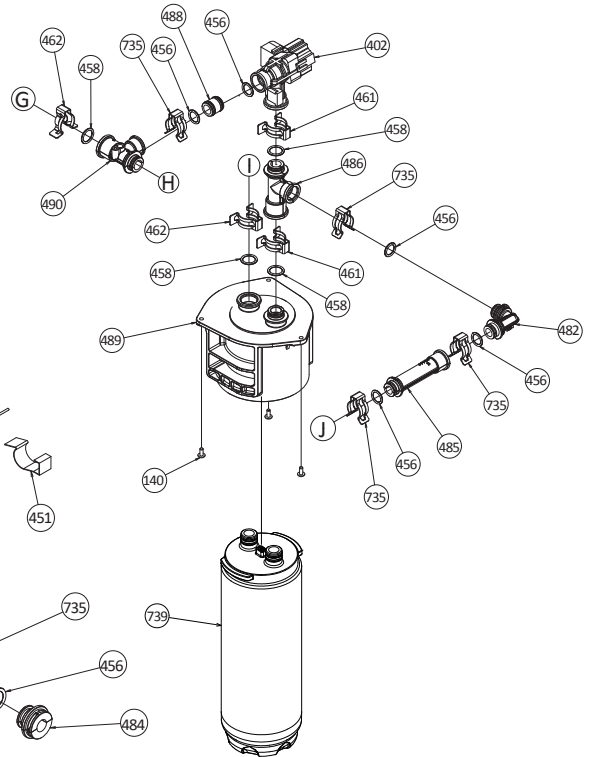

Water inlet

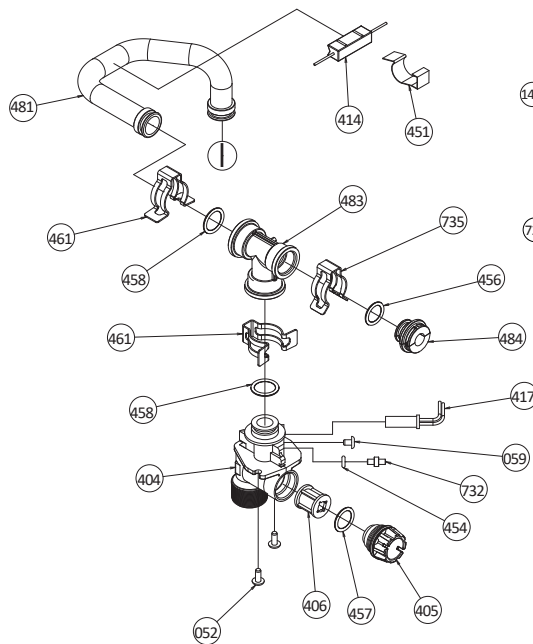

REPAIR PARTS

Parts list

No.	Description	Part #	No.	Description	Part #
001	Case assembly	N/A	416	Drain tube	N/A
002	Front cover	100320351	417	Inlet heater	N/A
003	Intake/Exhaust port assembly	100320352	418	Secondary heat exchanger assembly	100320516
004	Bracket	N/A	419	Large heat exchanger fixing plate	N/A
005	Top bracket	N/A	420	Heat exchanger gasket	100320392
006	Hose clamp	N/A	421	Small heat exchanger fixing plate L	N/A
007	Rain protection tray	100320353	422	Small heat exchanger fixing plate R	N/A
008	Rain protection plate	N/A	423	Hose clamp	N/A
009	Condensate drain port	100074203	431	Exhaust duct	N/A
050	Truss screw M4x12 (W/Washer) SUS410	N/A	432	Exhaust duct gasket	100320393
052	Truss screw M4x10 (Coated) SUS3	N/A	433	O-ring P60 FKM	100320394
053	Truss screw M4x10 SUS	N/A	434	Exhaust port cap	100320484
055	Hex head screw M4x8 FEZN	N/A	450	Outlet pipe	100320509
056	Pan screw M4x20 SUS410	N/A	451	Heater fixing plate	100074310
057	Tap tight screw M4x12 FEZN	N/A	452	Fuse fixing plate	N/A
058	Tapping screw M3x6 SUS3 Pan head	N/A	453	Heater fixing plate	N/A
059	Tapping screw M4x6 SUS3 Truss head	N/A	454	O-ring P4 FKM	100076303
063	Wire clamp 60	100074233	455	O-ring P6 FKM	100076305
064	Screw M4x10	N/A	456	O-ring P14 FKM	100076306
066	Pan screw M4x10	N/A	457	O-ring P15 FKM	100076307
067	Truss screw M4x14 S coated SUS	N/A	458	O-ring P16 FKM	100076308
068	Truss tapping screw M4x10 S	N/A	459	Fastener "4-11"	100074282
069	Pan sems screw M4x12 MFZN	N/A	461	Fastener "16A"	100074410
101	Metal knit burner	100320464	462	Fastener "16-25A"	100074389
102	Gas valve assembly	200320489	463	Fastener "6-15"	100074297
103	Fan motor	100320489	464	Flat heater	N/A
104	Gas pipe	100320488	465	Drain pipe	100320470
106	Rod gasket	100320421	466	Sec-heat exchanger in pipe	100320505
107	Rod holder gasket-	100320358	467	Pri-heat exchanger in pipe	100320504
108	Flame rod	100320503	468	Pri-heat exchanger out pipe	100320508
109	Igniter rod	100320503	469	Drain port	100320469
110	Rod holder	100320503	470	Thermistor fixing plate	N/A
111	Rod cap	N/A	471	O-ring P10 FKM	100320401
112	Mixing chamber assembly	100320465	472	Header connection w/drain port	100320520
113	Mixing chamber gasket	100320373	473	Header connection	100320483
115	Burner gasket	100320374	474	Header connection gasket	100320404
116	Gas connection A	100320375	481	Inlet pipe	100320507
117	Gas connection B	100320376	482	Joint B - Elbow pump outlet	100320481
118	Gas inlet	100320377	483	Joint C - Tee Mixing and inlet	100320518
119	Gas inlet ring	100320378	484	Joint D	100320511
122	Air damper assembly	100320319	485	Joint E - Pump outlet straight	100320515
123	Pressure sensor	100320320	486	Joint F - 3 way connection with SCM,return	100320519
124	Silencer	N/A	487	Joint G - Pump inlet elbow	100320482
125	O-ring P40 EPDM	100320379	488	Brass joint	100320467
126	Venturi body	100320520	489	SCM manifold assembly	100314460
127	Oval ring NBR	100320381	490	3 way connection - Bypass, heat exchanger	100320517
129	Orifice gasket	100320382	701	Computer board 160X3P	100320425
130	Gas solenoid valve assembly	100320383	701	Computer board 180X3P	100320426
131	Gas solenoid valve wire	N/A	701	Computer board 199X3P	100320427
132	O-ring P50 FKM	100320384	702	Rubber grommet	100076470
133	Venturi duct	100320502	703	Surge box	100074468
134	O-ring P75 FKM	100320386	704	120 VAC wire	100074601
135	Pan screw M3x18 FEZN	N/A	705	Surge box fixing plate	N/A
136	Truss screw M4x12	N/A	706	120 VAC Power ON-OFF switch	100074326
138	Tapping screw M4x12 FEZN	N/A	707	Flat heater extension wire	N/A
139	Tapping tight screw M3x8	N/A	708	Wiring for Gas valve, HI-limit, OHCF, Igniter	100320414
140	Truss screw M4x12 (Coated) SUS3	N/A	709	Flame rod wire	N/A
141	Pan screw M4x10	N/A	710	Igniter assembly	100320415
145	Orifice NA	100320487	711	Igniter fixing plate	N/A
145	Orifice LP	100320420	714	120V cables	N/A
152	O-ring P16 NBR	100320422	715	24V cables	100320416
153	O-ring P22 NBR	100320423	716	Computer board cover	N/A
401	Primary heat exchanger assembly	100320512	718	Exhaust thermistor	100320521
402	Flow adjustment valve/Flow sensor	100320486	721	Hi-limit switch wire	N/A
403	Bypass valve	100320466	722	Built-in controller	100276680
404	Water inlet	100320526	723	Fixing plate	N/A
405	Inlet filter plug	100320506	726	Recirculation pump	100320513
406	Inlet water filter	100320506	727	Wall mounting bracket	100320419
407	Inlet thermistor	100320523	731	Return thermistor	100320525
408	Outlet thermistor	100320524	732	Closing plug	100320510
409	Water outlet	100320527	735	Fastener "12.7"	100076400
411	Heat exchanger thermistor	100320522	736	Pump fixing plate	N/A
412	Hi-Limit switch	100320390	737	Igniter cord	N/A
413	Overheat-cut-off fuse	100074334	738	Recirculation pump wire	N/A
414	Block heater	100074684	739	X3™ Cartridge	100314491
415	Block heater	100074683			

OUTPUT TEMPERATURE CHART

The chart is based on a properly sized gas line and installation at 0-2,000 ft (0-610 m).
 The water heater will de-rate 4% per 1,000 ft (305 m) of elevation increase above 3,000 ft (914 m.)

160X3P Output Temperature vs. GPM (Max. 6.6 GPM) with Various Inlet Water Temperature

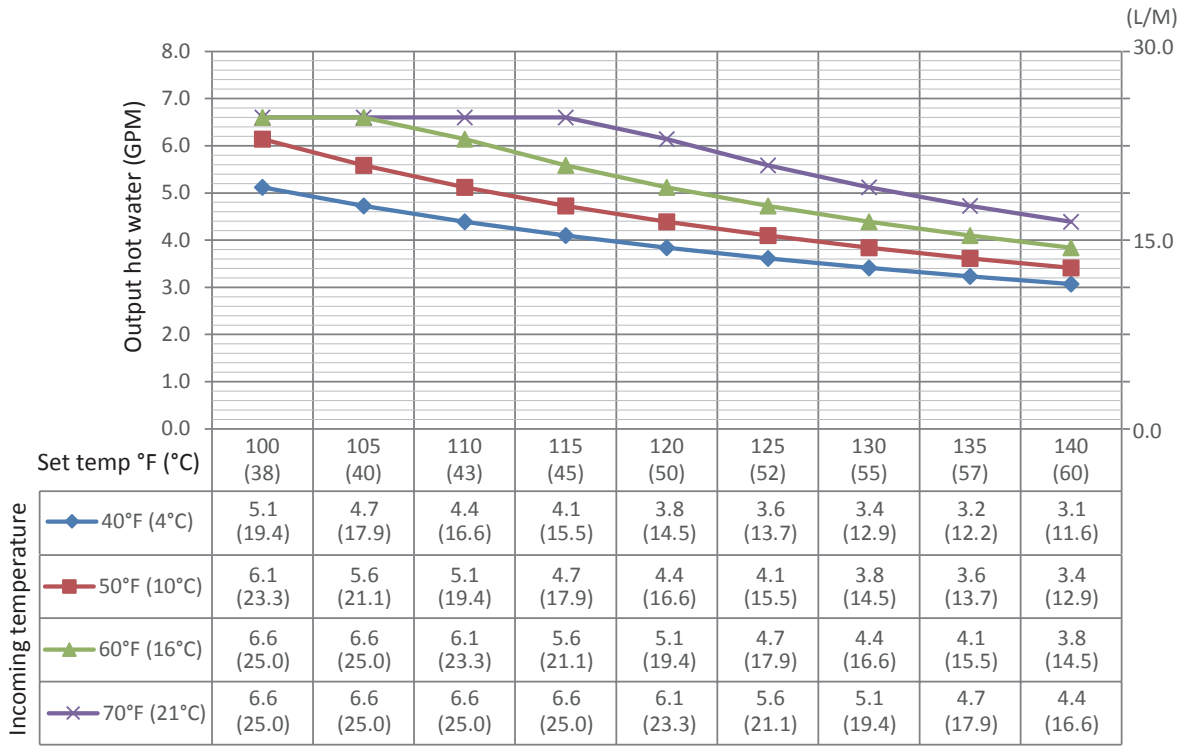

180X3P Output Temperature vs. GPM (Max. 8.0 GPM) with Various Inlet Water Temperature

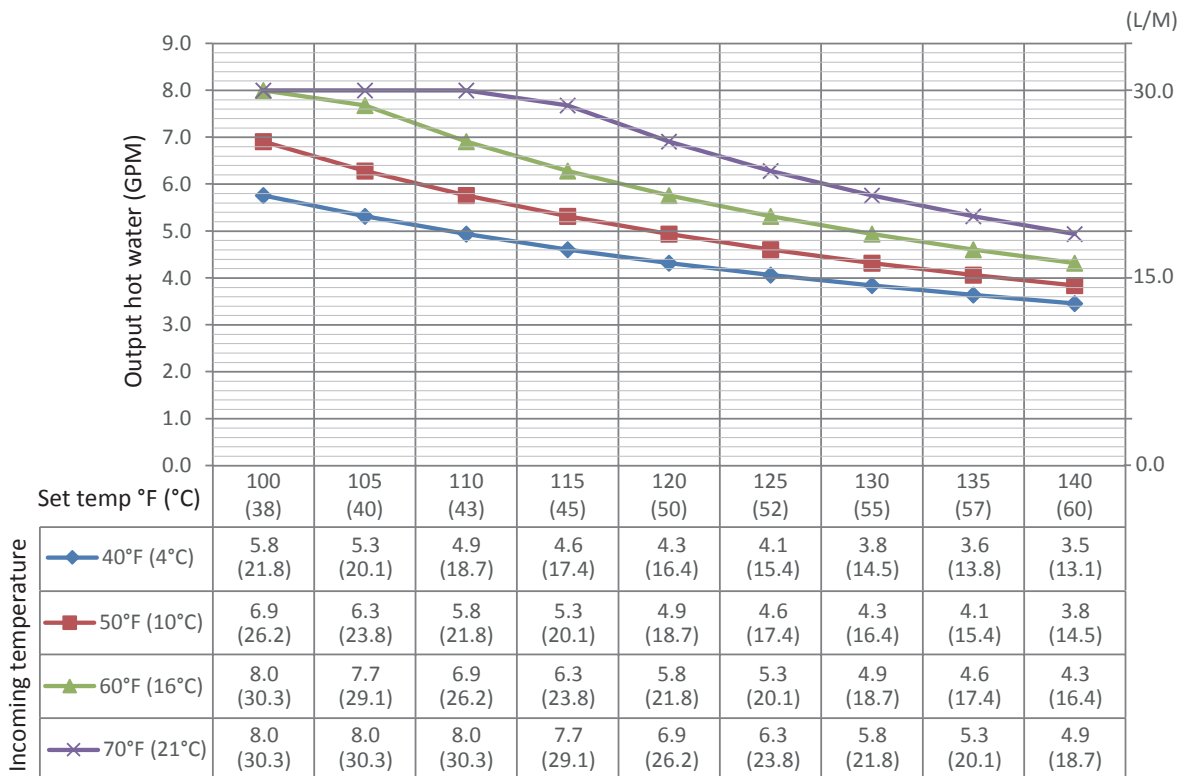

OUTPUT TEMPERATURE CHART

199X3P

Output Temperature vs. GPM (Max. 10.0 GPM) with Various Inlet Water Temperature

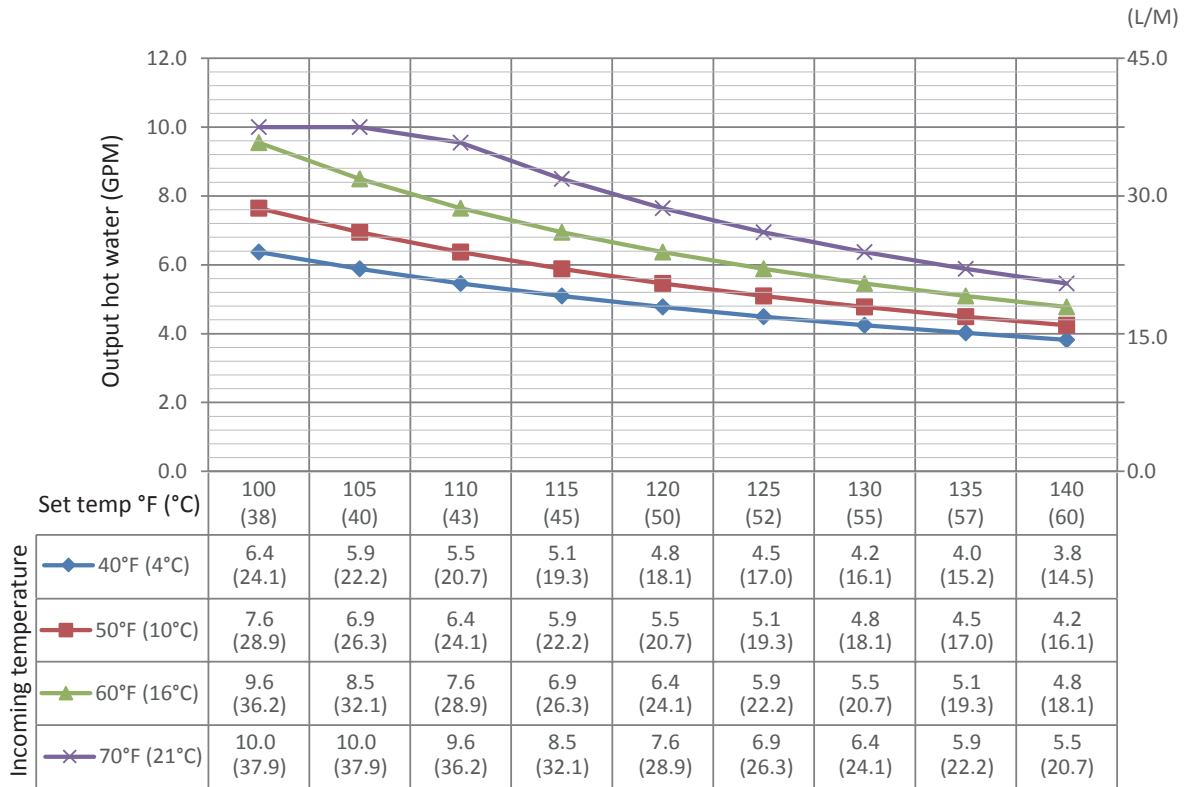

When the set temperature is 130°F (55°C) or higher, maximum flow rate is limited to 8.0 GPM.

7J8071-1
2000570774
(REV. B)