



PROLINE® XE CONDENSING TANKLESS WITH X3® SCALE PREVENTION TECHNOLOGY

State has combined water heating and treatment in a product designed to revolutionize tankless water heating. Our new condensing gas tankless line features X3 Technology that extends life on the unit up to three times longer than traditional/unprotected models.

FEATURES:

X3 SCALE PREVENTION TECHNOLOGY (PATENT PENDING)

- No annual descaling required
- No scale buildup means the heater maintains like-new performance longer

ENERGY STAR® QUALIFIED+

DURABLE HEAT EXCHANGER

- Primary heat exchanger is constructed of a commercial-grade copper that is more resilient to corrosion. Copper is 25x better at heat transfer than Stainless Steel, thus stabilizing outgoing water temperatures quicker
- Secondary heat exchanger is made of 316L Stainless Steel to protect against corrosion

QUALIFIED AS LEAD FREE UNDER THE SAFE DRINKING WATER ACT

SAFETY FEATURES

- Exhaust & Water Temperature Safety Control
- Overheat Cut-Off Fuse
- Air-Fuel Ratio (AFR) Sensor

INTERNAL FREEZE PROTECTION SYSTEM

RECIRC CAPABLE

- Tankless water heaters with X3 Technology are approved to work with an external recirculation pump and cross-over valve. See manual for full details.

POWER DIRECT VENT DESIGN

+Select models

- Category III or IV venting can be used
- Exhaust, 3" PVC up to 70'; 4" PVC up to 100'
- Provides flexible venting with PVC, CPVC, polypropylene, or ABS Pipe for Intake and Exhaust (solid core only)

ACCESSORIES

- Pipe Cover
- Neutralizer Kit
- X3 Freeze Protection Kit
- Concentric Termination
- Recess Box

WARRANTY

- No hardwater exclusions in the industry's first "peace of mind" limited warranty
- 15-year limited warranty on heat exchanger in residential applications
- 5-year limited warranty on all parts in residential applications
- 1-year limited warranty on heat exchanger and parts in commercial applications
- For complete information, consult written warranty or go to statewaterheaters.com

INDOOR GTS-240X3, GTS-340X3, GTS-540X3



OUTDOOR GTS-240X3, GTS-340X3, GTS-540X3



ANSI Z21.10.3 • CSA 4.3

SOLID. STATE.



COMMERCIAL-GRADE

RESIDENTIAL GAS WATER HEATERS

CONDENSING TANKLESS WITH X3® SCALE PREVENTION TECHNOLOGY

Model Number	Type	Gas Consumption Input		Supply Gas Pressure		UEF	Maximum GPM*	Hot/Cold Connections	Gas Connection	Dimensions in Inches				Approx. Shipping Weight (lbs)
		Minimum BTU/H	Maximum BTU/H	Minimum in. W.C.	Maximum in. W.C.					Height	Width	Depth	Height with Cartridge	
Indoor Models														
GTS-240X3-NIH	Natural	15,000	160,000	4.0	10.5	0.94	6.6	3/4" NPT	3/4" NPT	23-5/8	17-3/4	11-1/4	35-9/16	72
GTS-240X3-PIH	Propane	13,000	160,000	8.0	14.0	0.94	6.6	3/4" NPT	3/4" NPT	23-5/8	17-3/4	11-1/4	35-9/16	72
GTS-340X3-NIH+	Natural	15,000	180,000	4.0	10.5	0.95	8	3/4" NPT	3/4" NPT	23-5/8	17-3/4	11-1/4	35-9/16	72
GTS-340X3-PIH+	Propane	13,000	180,000	8.0	14.0	0.95	8	3/4" NPT	3/4" NPT	23-5/8	17-3/4	11-1/4	35-9/16	72
GTS-540X3-NIH	Natural	15,000	199,000	4.0	10.5	0.93	10	3/4" NPT	3/4" NPT	23-5/8	17-3/4	11-1/4	35-9/16	73
GTS-540X3-PIH	Propane	13,000	199,000	8.0	14.0	0.93	10	3/4" NPT	3/4" NPT	23-5/8	17-3/4	11-1/4	35-9/16	73
Outdoor Models														
GTS-240X3-NEH+	Natural	15,000	160,000	4.0	10.5	0.95	6.6	3/4" NPT	3/4" NPT	23-5/8	17-3/4	11-1/4	35-9/16	71
GTS-240X3-PEH+	Propane	13,000	160,000	8.0	14.0	0.95	6.6	3/4" NPT	3/4" NPT	23-5/8	17-3/4	11-1/4	35-9/16	71
GTS-340X3-NEH	Natural	15,000	180,000	4.0	10.5	0.94	8	3/4" NPT	3/4" NPT	23-5/8	17-3/4	11-1/4	35-9/16	71
GTS-340X3-PEH	Propane	13,000	180,000	8.0	14.0	0.94	8	3/4" NPT	3/4" NPT	23-5/8	17-3/4	11-1/4	35-9/16	71
GTS-540X3-NEH+	Natural	15,000	199,000	4.0	10.5	0.95	10	3/4" NPT	3/4" NPT	23-5/8	17-3/4	11-1/4	35-9/16	73
GTS-540X3-PEH+	Propane	13,000	199,000	8.0	14.0	0.95	10	3/4" NPT	3/4" NPT	23-5/8	17-3/4	11-1/4	35-9/16	73

15-150 PSI Water Pressure. 40 PSI or above recommended for maximum flow.

*Current numbers based on factory testing; 0.5 GPM for activation; 0.4 GPM required for continuous fire after initial ignition.

Indoor models are certified from sea level to 10,100 ft. elevations. Outdoor models are certified from sea level to 6,000 ft. elevation.

+GTS-340X3-NIH, GTS-340X3-PIH, GTS-240X3-NEH, GTS-240X3-PEH, GTS-540X3-NEH and GTS-540X3-PEH are ENERGY STAR® Qualified

240X3 OUTPUT TEMP VS. GPM

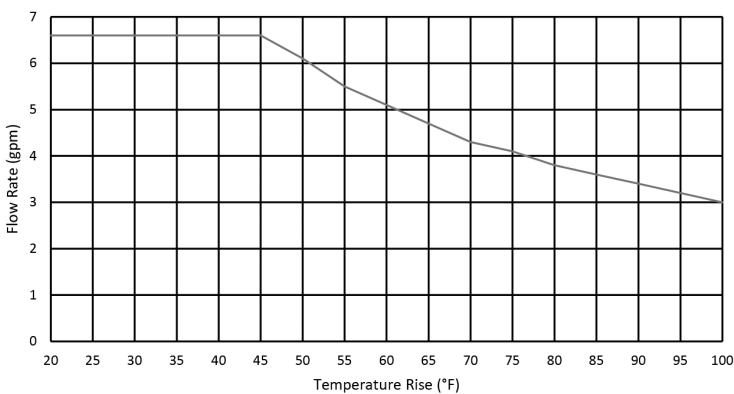

240X3 PRESSURE LOSS

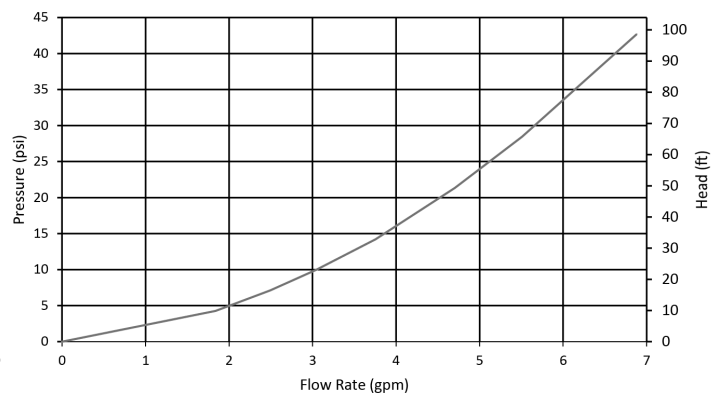



COMMERCIAL-GRADE

RESIDENTIAL GAS WATER HEATERS

340X3 OUTPUT TEMP VS. GPM

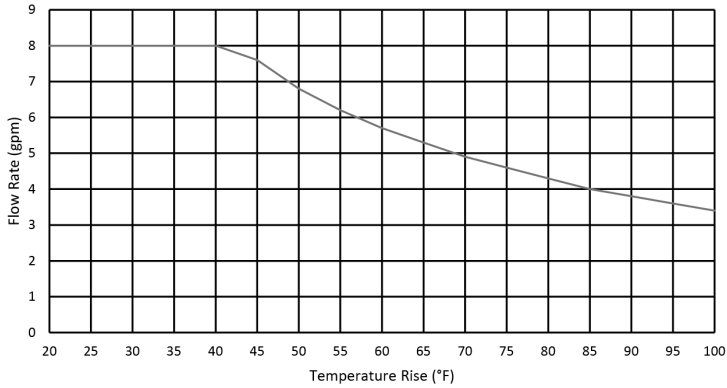

340X3 PRESSURE LOSS

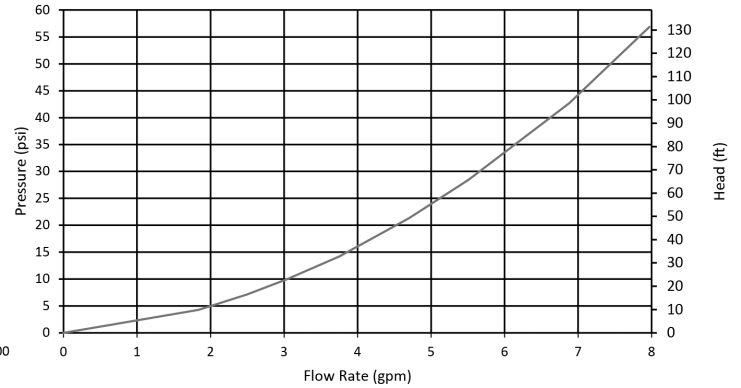

540X3 OUTPUT TEMP VS. GPM

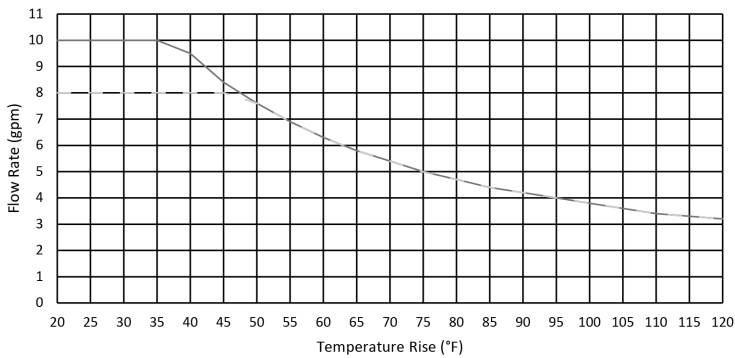

— Set Temperature: 100-125°F - - - Set Temperature: 130-160°F

540X3 PRESSURE LOSS

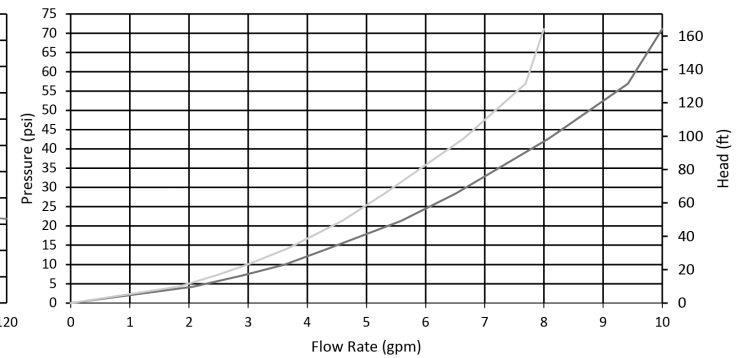

— Set Temp: 100-125°F — Set Temp: 130-160°F
 Max flow is 8 gpm when set temp above 125

INDOOR DIMENSIONS

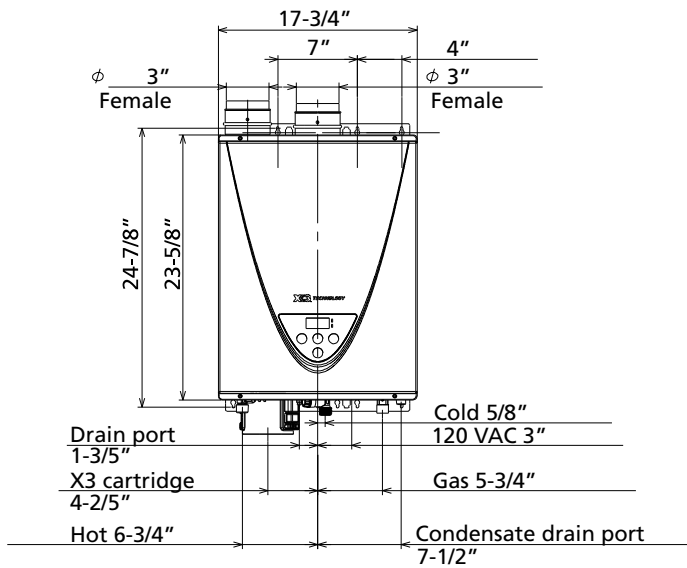

FRONT

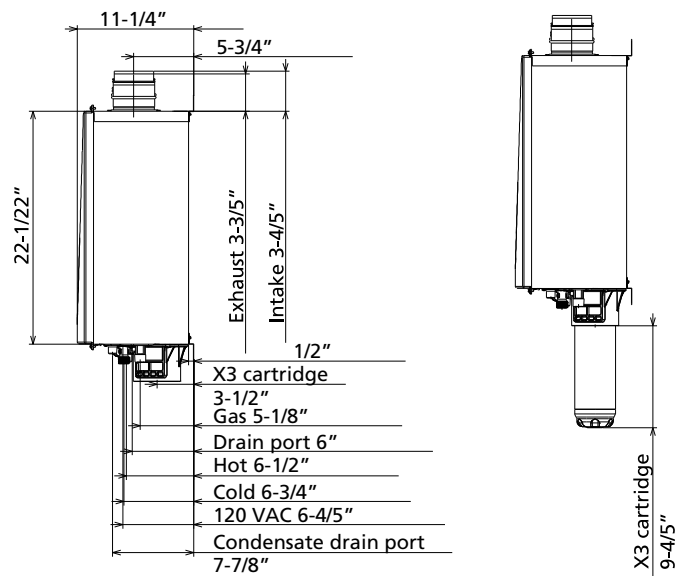

SIDE

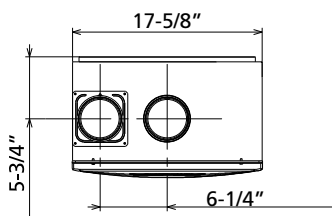

TOP

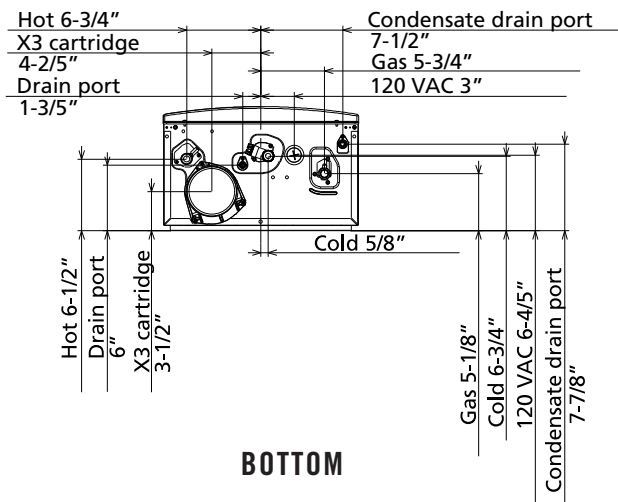

BOTTOM

OUTDOOR DIMENSIONS

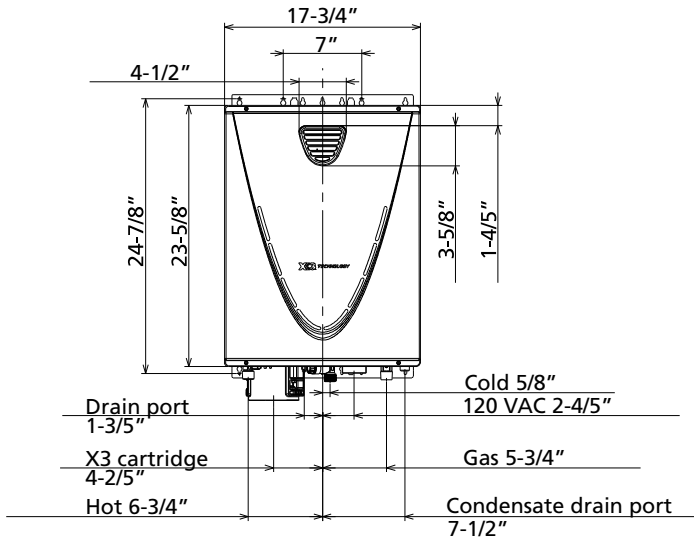

FRONT

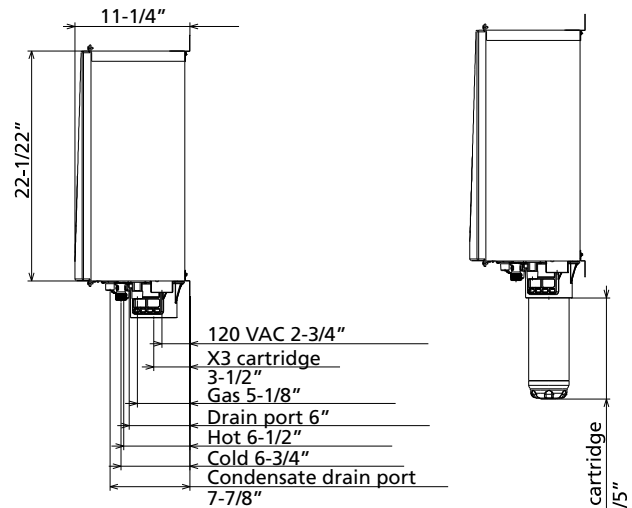

SIDE

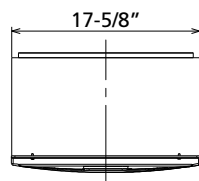

TOP

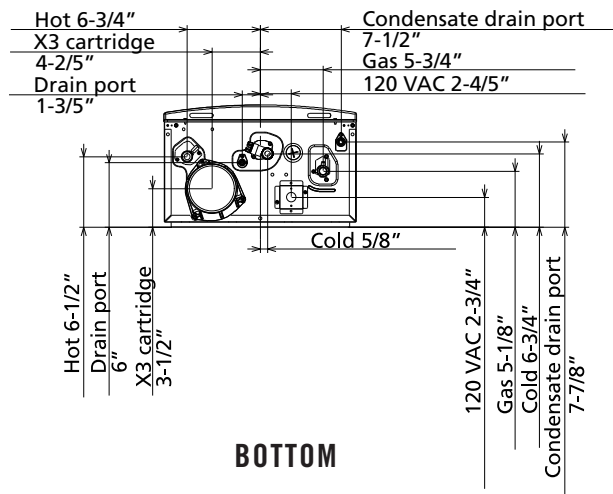

BOTTOM



SUGGESTED SPECIFICATION FOR GTS-540X3-NIH OR GTS-540X3-NEH

The fully modulating, on-demand, condensing gas fired tankless water heater(s) shall be State Tankless Water Heater model GTS-540X3-NIH or GTS-540X3-NEH, having a maximum input rating of 199,000 Btu/h and available in NG or LP. The heater shall have ¾ in. male NPT water and gas connections. The inlet gas supply pressures shall be 4.0 in. WC (min.) up to 10.5 in. WC (max.) for NG and 8.0 in. WC (min.) up to 14 in. WC (max.) for LP. The water heater shall have the integrated X3 Scale Prevention Technology to prevent scaling of the heat exchangers. The indoor heater(s) shall incorporate an integrated temperature controller that will provide diagnostic information, fault history, and heater set temperature. The outdoor heater shall be factory supplied with a temperature remote, 100209924, that can be installed up to 400 ft. from the heater using 20 gauge (minimum) control wire. The temperature remote shall provide diagnostic information, fault history, and heater set temperature. The heater shall operate using 120 V / 60 Hz power source. The indoor heater will incorporate a factory installed power cord.

The indoor heater shall be vented with 3" or 4" diameter schedule 40 PVC (solid core), CPVC, ABS, polypropylene or category IV vent pipe with a length not to exceed 70 ft. (equivalent) for 3" vent or 100 ft. (equivalent) for 4" vent, terminating horizontally or vertically. The intake pipe may use material such as PVC, CPVC, ABS, aluminum, or Category IV pipe and cannot exceed 70 ft. (equivalent) for 3" vent or 100 ft. (equivalent) for 4" vent. The water heater shall use a commercial grade copper alloy, fin tube primary heat exchanger with quick release brass or bronze waterways. The secondary heat exchanger shall be constructed from stainless steel 316L. The heater shall be controlled by an onboard solid-state printed circuit board which uses the following factory installed components: thermistors to monitor inlet & outlet water temperature and exhaust temperature; a flow sensor to measure flow rate; a flame sensor to monitor combustion; an air-fuel ratio rod to measure and adjust operation in order to maintain optimal combustion efficiency. The heater also consists of inline fusing and surge absorbers for electrical surge protection, an electronic spark igniter, aluminized stainless steel burners, hi-limit temperature switches to monitor water and exhaust temperatures, modulating gas valve, an overheat cutoff fuse, ceramic heating blocks to protect the heat exchanger and water piping. The indoor heater shall incorporate auto-fire system for additional freeze protection. The indoor model shall include an exhaust temperature monitoring system using an exhaust thermistor and automatic hi-limit switch to maintain safe exhaust temperatures for sch. 40 PVC. The heater shall have a built-in condensate trap for the secondary heat exchanger. The heater shall incorporate a condensate drain blockage detector to provide safe operations and prevent overflow.

The heater shall be design certified by CSA according to CSA/ANSI Z21.10.3•CSA 4.3, approved for sale in the United States, has a minimum uniform energy factor of 0.93, meets the energy efficiency requirements of the U. S. Department of Energy and ASHRAE 90.1, complies with SCAQMD Rule 1146.2 and other air quality districts with similar requirements for low NOx emissions of 14 ng/J or 20 ppm.