



COMMERCIAL-GRADE RESIDENTIAL TANKLESS WATER HEATERS

PROLINE® XE NON-CONDENSING CONCENTRIC VENT WITH X3® SCALE PREVENTION TECHNOLOGY

The fully modulating, gas fired, tankless water heaters from American offer sealed combustion and power vented flue supply making them ideal for residential hot water systems. Now equipped with X3 Technology, these non-condensing units offer extended service life of up to three times longer than traditional/unprotected models.

FEATURES:

X3 SCALE PREVENTION TECHNOLOGY

- No annual descaling required
- No scale buildup means the heater maintains like-new performance longer
- Isolation valves not required
- Pressure relief valve included

CONCENTRIC VENT DESIGN

FIELD CONVERTIBLE FROM NATURAL GAS TO PROPANE

COMPLIES WITH SCAQMD RULE 1146.2 AND OTHER AIR QUALITY MANAGEMENT DISTRICTS WITH SIMILAR NOX EMISSION REQUIREMENTS OF 14 NG/J OR 20 PPM

COMPLIES WITH SJVACPD RULE 4308 FOR LP NOX EMISSION REQUIREMENTS OF 77 PPM

MAXIMUM FLOW RATES UP TO 10.0 GPM

COPPER HEAT EXCHANGER

- 25x better heat transfer than stainless steel thus stabilizing outgoing water temperature quicker and reducing pressure drop across the heat exchanger

INDOOR MODELS ONLY

COMPLIES WITH LEAD FREE STANDARDS

RECIRC CAPABLE

- Approved to work with an external recirculation pump and crossover valve.

SAFETY FEATURES:

- Built-in Freeze Protection
- Manual Reset Hi-Limit (Up to 194°F)
- Overheat Cutoff Fuse
- Inlet and Outlet Thermistors for Constant
- Temperature Monitoring
- Air Fuel Ratio Rod
- Flame Sensor

VENTING AND COMBUSTION

- Direct vent APNC35 concentric vent system
- Vertical or Horizontal Vent Termination Installation
- 43' Max Length, 4 Elbows max (87° elbows = 5' equivalent length)
- Power Direct Vent
- Electronic Ignition - No Pilot Light

OPTIONAL ACCESSORIES

- Isolation Valve Kit
- Remote Control
- X3 Freeze Protection Kit
- Remote Control

WARRANTY

- 15-year limited warranty on heat exchanger in residential applications
- 1-year limited warranty on heat exchanger in commercial applications
- 5-years Residential parts
- 1-year Commercial parts
- 1-year labor coverage for warranty repairs

INDOOR MODELS GT-310CX3, GT-510CX3



CSA/ANSI Z21.10.3 • CSA 4.3



COMMERCIAL-GRADE RESIDENTIAL TANKLESS WATER HEATERS

NON-CONDENSING CONCENTRIC VENT WITH X3® SCALE PREVENTION TECHNOLOGY

Model Number	Type*	Gas Consumption Input		Inlet Gas Pressure**		UEF	Maximum GPM***	Hot/Cold Connections	Gas Connection	Dimensions in Inches				Approx Shipping Weight (lbs)
		Minimum BTU/H	Maximum BTU/H	Minimum in. W.C.	Maximum in. W.C.					Height	Width	Depth	Height with Cartridge	
GT-310CX3	Natural	15,000	190,000	4.0	10.5	0.81	8	3/4" NPT	3/4" NPT	20-1/2	13-3/4	11-1/2	36-1/8	51
GT-510CX3	Natural	15,000	199,000	4.0	10.5	0.81	10	3/4" NPT	3/4" NPT	20-1/2	13-3/4	11-1/2	36-1/8	51

15-150 psi water pressure. 40 psi or above recommended for maximum flow.

*Field gas convertible from natural gas to propane. Conversion kit is included with the heater.

**For Propane, minimum inlet gas pressure is 8.0 in. W.C. and maximum inlet gas pressure is 14.0 in. W.C.

***Current numbers based on factory testing; 0.5 GPM required for activation; 0.4 GPM required for continuous fire after initial ignition.

Suitable for commercial applications.

Certified from sea level to 10,100 ft. elevations.

INDOOR DIMENSIONS

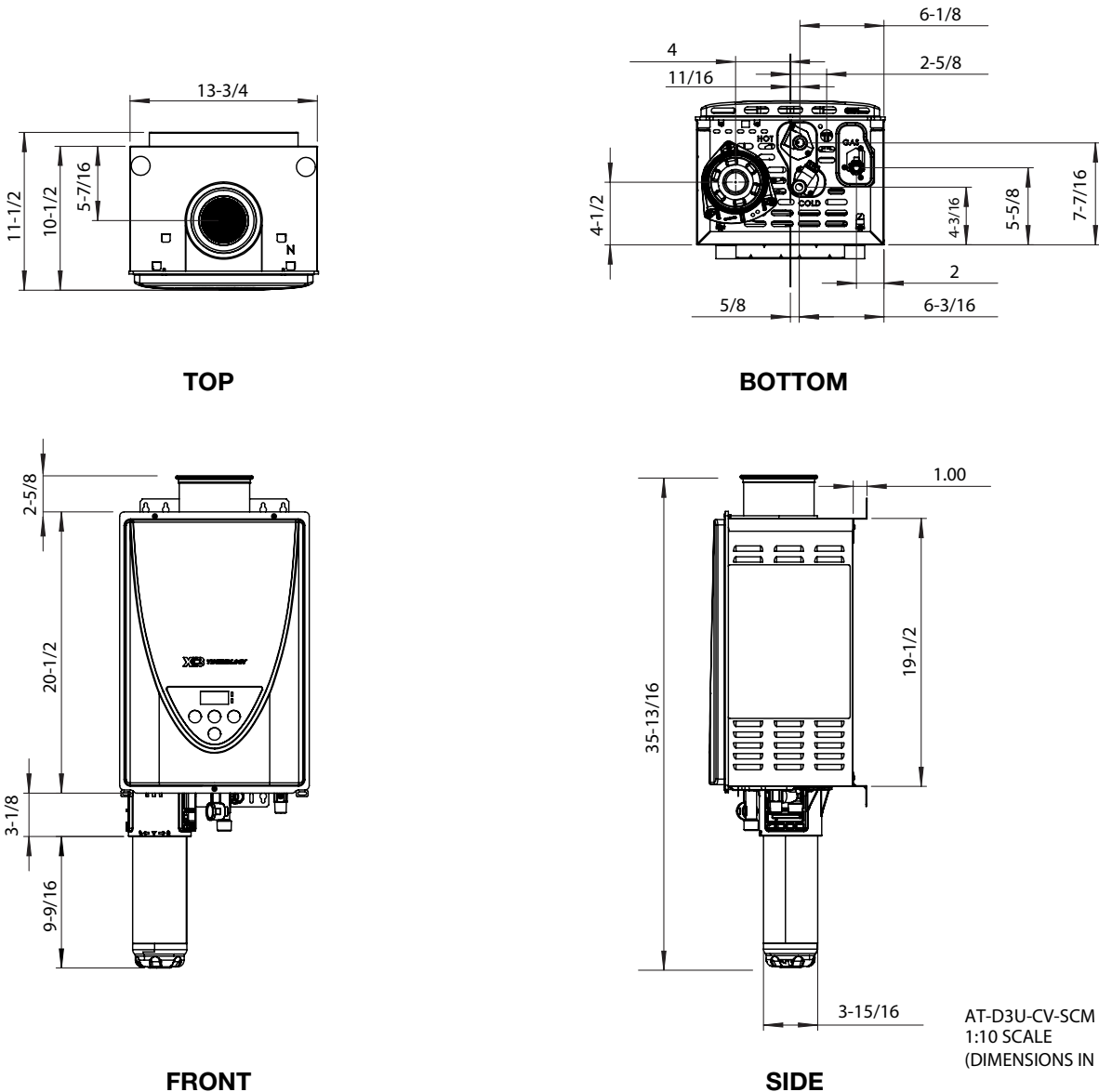



COMMERCIAL-GRADE RESIDENTIAL TANKLESS WATER HEATERS

310CX3 OUTPUT TEMP VS. GPM

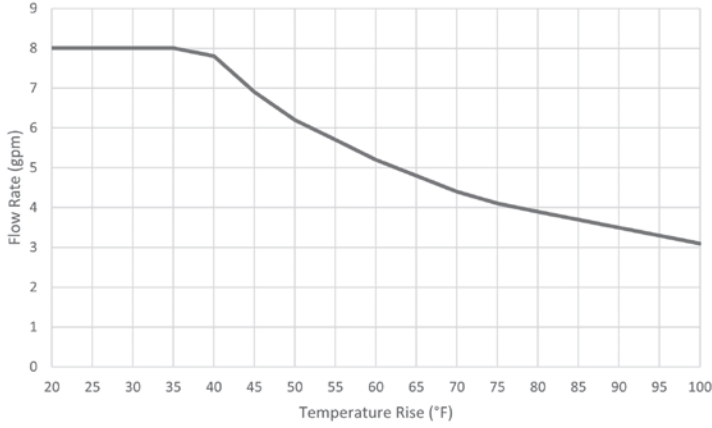

310CX3 PRESSURE LOSS

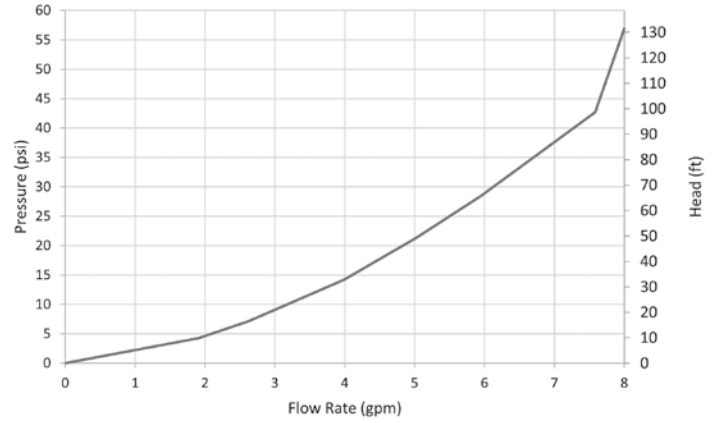

510CX3 OUTPUT TEMP VS. GPM

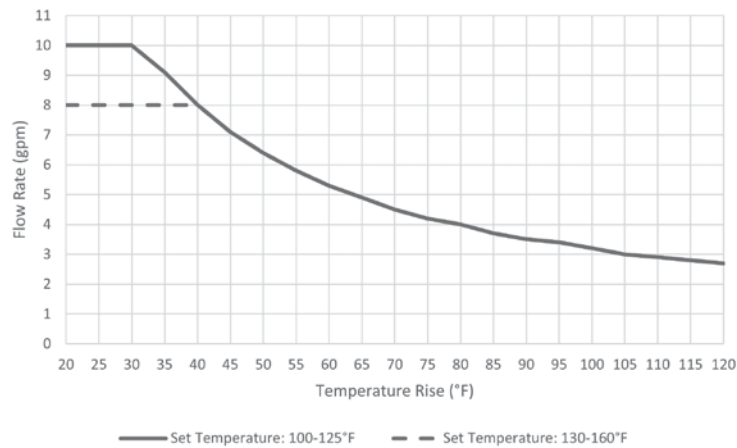

510CX3 PRESSURE LOSS

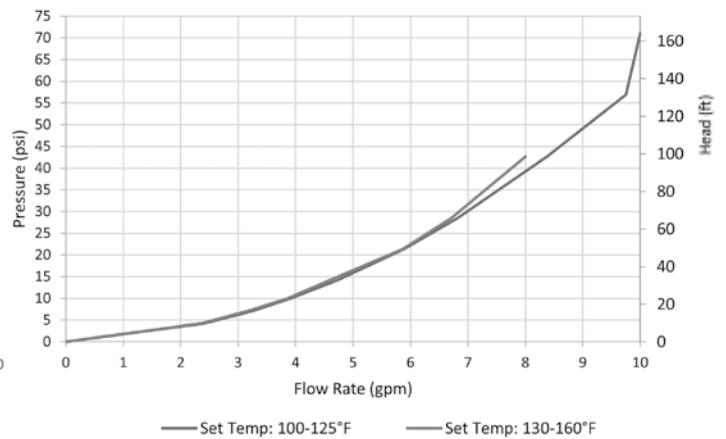



COMMERCIAL-GRADE RESIDENTIAL TANKLESS WATER HEATERS

SUGGESTED SPECIFICATIONS FOR THE GT-510CX3

The fully modulating, on-demand, non-condensing gas fired tankless water heater shall be American Tankless Water Heater, having a maximum input rating of 199,000 Btu/h and available in natural gas (NG). For use with propane (LP) gas, the heater shall be field converted using the factory supplied conversion kit. The conversion kit shall be supplied with the heater. The heater shall have ¾ in. male NPT water and gas connections. The inlet gas supply pressures shall be 4.0 in. WC (min.) up to 10.5 in. WC (max.) for NG and 8.0 in. WC (min.) up to 14 in. WC (max.) for LP. The heater shall incorporate an integrated temperature controller that will provide diagnostic information, fault history, and heater set temperature. The heater shall operate using 120 V / 60 Hz power source. The heater will incorporate a factory installed power cord.

The indoor heater shall be vented with a 3" / 5" direct vent APNC35 concentric vent with a length not to exceed 43 ft. (equivalent), terminating horizontally or vertically with no more than four 87° elbows.

The water heater shall use a commercial grade copper alloy, fin tube heat exchanger with quick release brass or bronze waterways. The heater shall be controlled by an onboard solid-state printed circuit board which uses the following factory installed components: thermistors to monitor water temperature; a flow sensor to measure flow rate; a flame sensor to monitor combustion; and an air-fuel ratio rod to measure and adjust air input in order to maintain optimal combustion efficiency. The heater also consists of inline fusing and surge absorbers for electrical surge protection, an electronic spark igniter, aluminized stainless steel burners, hi-limit switch to monitor water temperature, modulating gas valve, overheat cutoff fuse, and dual freeze protection that incorporates heating blocks and the ability to automatically fire the heater to protect the heat exchanger.

The heater models are design certified by CSA according to CSA/ANSI Z21.10.3 • CSA 4.3, approved for sale in the United States, meets the energy efficiency requirements of the U. S. Department of Energy and ASHRAE 90.1, complies with SCAQMD Rule 1146.2 and other air quality districts with similar requirements for low NOx emissions of 14 ng/J or 20 ppm. Compliance also includes SJVACPD Rule 4308 for LP NOx emission requirements of 77 PPM.

For technical information call (800) 999-9515. American Water Heaters reserves the right to make product changes or improvements without prior notice.