



COMMERCIAL-GRADE

RESIDENTIAL TANKLESS WATER HEATERS

CONDENSING TANKLESS WITH INTEGRATED RECIRCULATION PUMP

Ultra-Low NOx gas tankless water heaters with condensing technology featuring an up to 0.95 Uniform Energy Factor (UEF) which lowers operating costs and is environmentally friendly.

FEATURES:

INTEGRATED RECIRCULATION PUMP

ENERGY STAR® QUALIFIED+

AVAILABLE IN NATURAL GAS OR PROPANE (LP)

INDOOR MODEL

- Includes integrated temperature and pump controls with advanced diagnostics that simplify installation and troubleshooting
- Factory-installed power cord

OUTDOOR MODEL

- Includes a wall mount temperature remote controller and advanced diagnostics to simplify troubleshooting

DURABLE HEAT EXCHANGER

- Primary heat exchanger is constructed of a commercial-grade copper that is more resilient to erosion.
- Secondary heat exchanger is made of type 316L stainless steel to protect against corrosion.

EASY-LINK 540P WITH THREE OTHER 540 TO INCREASE FLOW CAPACITY

COMMON VENT UP TO 8 UNITS

COMPLIES WITH LEAD FREE STANDARDS

+Select models

SAFETY FEATURES:

- Air-Fuel Ratio (AFR) Sensor
- Exhaust & Water Temperature Safety Control
- Overheat Cut-Off Fuse

INTERNAL FREEZE PROTECTION SYSTEM

POWER DIRECT VENT DESIGN

- Category IV venting can be used
- Exhaust, 3" PVC Venting up to 70 Feet or 4" PVC Venting up to 100 Feet
- Provides flexible venting with PVC, CPVC, or ABS Pipe for Intake and Exhaust (solid core only).

ACCESSORIES

- Pipe Cover
- Neutralizer Kit
- Isolation Valve Kits
- Concentric Termination
- Product Preservers® Anti-Scale System

WARRANTY

- 15-year limited warranty on heat exchanger in residential applications
- 5-year limited warranty on heat exchanger in commercial applications
- 5-year warranty on all parts

INDOOR MODELS GTS-540P-NIH AND GTS-540P-PIH



OUTDOOR MODELS GTS-540P-NEH AND GTS-540P-PEH

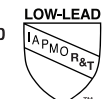

SOLID. STATE.



ANSI Z21.10.3 • CSA 4.3



COMMERCIAL-GRADE RESIDENTIAL TANKLESS WATER HEATERS

CONDENSING TANKLESS WITH INTEGRATED RECIRCULATION PUMP

Model Number	Type	Gas Consumption Input		Inlet Gas Pressure		UEF	Maximum GPM*	Hot/Cold Connections	Gas Connection	Dimensions in Inches			Approx Shipping Weight (lbs)
		Minimum BTU/H	Maximum BTU/H	Minimum in. W.C.	Maximum in. W.C.					Height	Width	Depth	
Indoor Models													
GTS-540P-NIH	Natural	15,000	199,000	4.0	10.5	0.93	10	3/4" NPT	3/4" NPT	23-5/8	17-3/4	11-1/4	71
GTS-540P-PIH	Propane	13,000	199,000	8.0	14.0	0.93	10	3/4" NPT	3/4" NPT	23-5/8	17-3/4	11-1/4	71
Outdoor Models													
GTS-540P-NEH*	Natural	15,000	199,000	4.0	10.5	0.95	10	3/4" NPT	3/4" NPT	23-5/8	17-3/4	11-1/4	69
GTS-540P-PEH*	Propane	13,000	199,000	8.0	14.0	0.95	10	3/4" NPT	3/4" NPT	23-5/8	17-3/4	11-1/4	69

15-150 psi Water Pressure. 40 psi or above recommended for maximum flow.

*Current numbers based on factory testing; 0.5 GPM for activation; 0.4 GPM required for continuous fire after initial ignition.

Indoor models are certified from sea level to 10,100 ft. elevations. Outdoor models are certified from sea level to 6,000 ft. elevation.

*GTS-540P-NEH and GTS-540P-PEH are ENERGY STAR® Qualified

540P FLOW RATE vs TEMPERATURE RISE

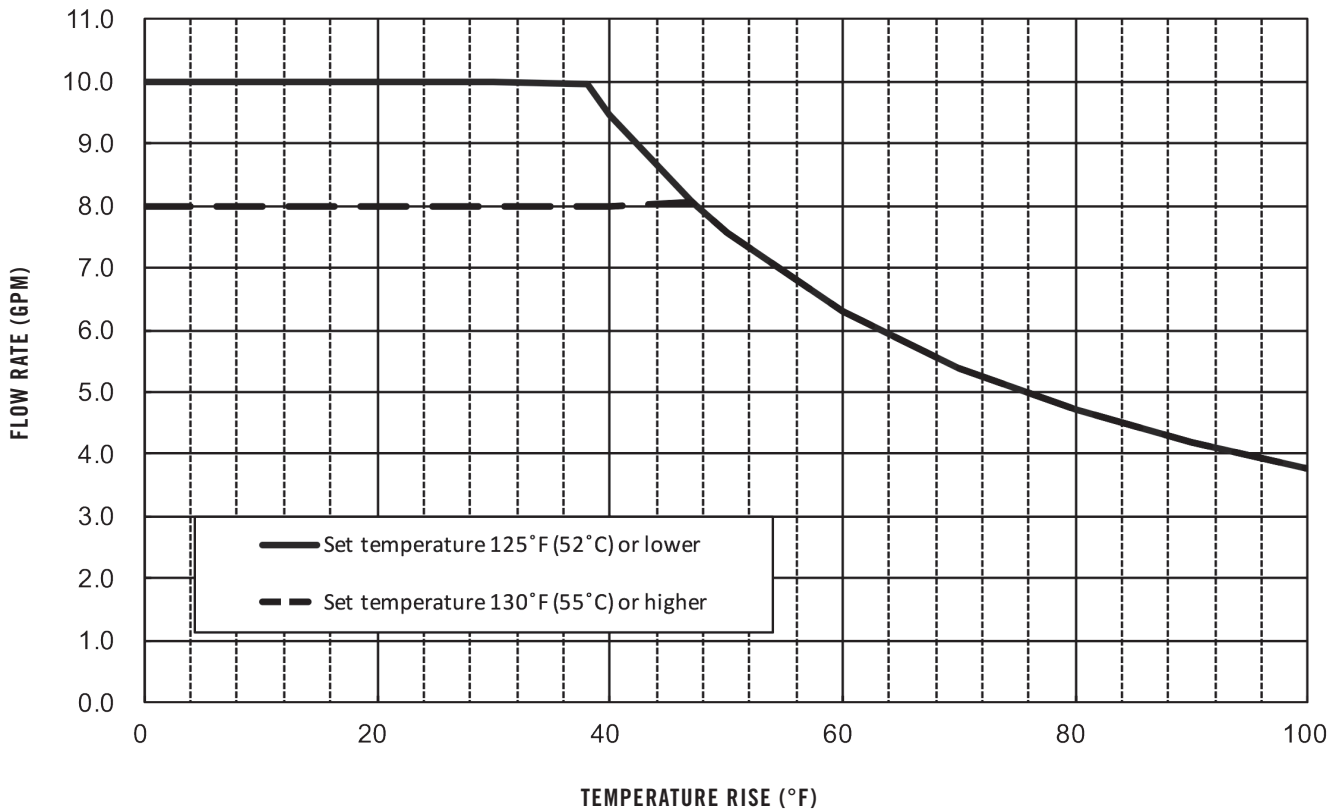

540P Pressure Loss

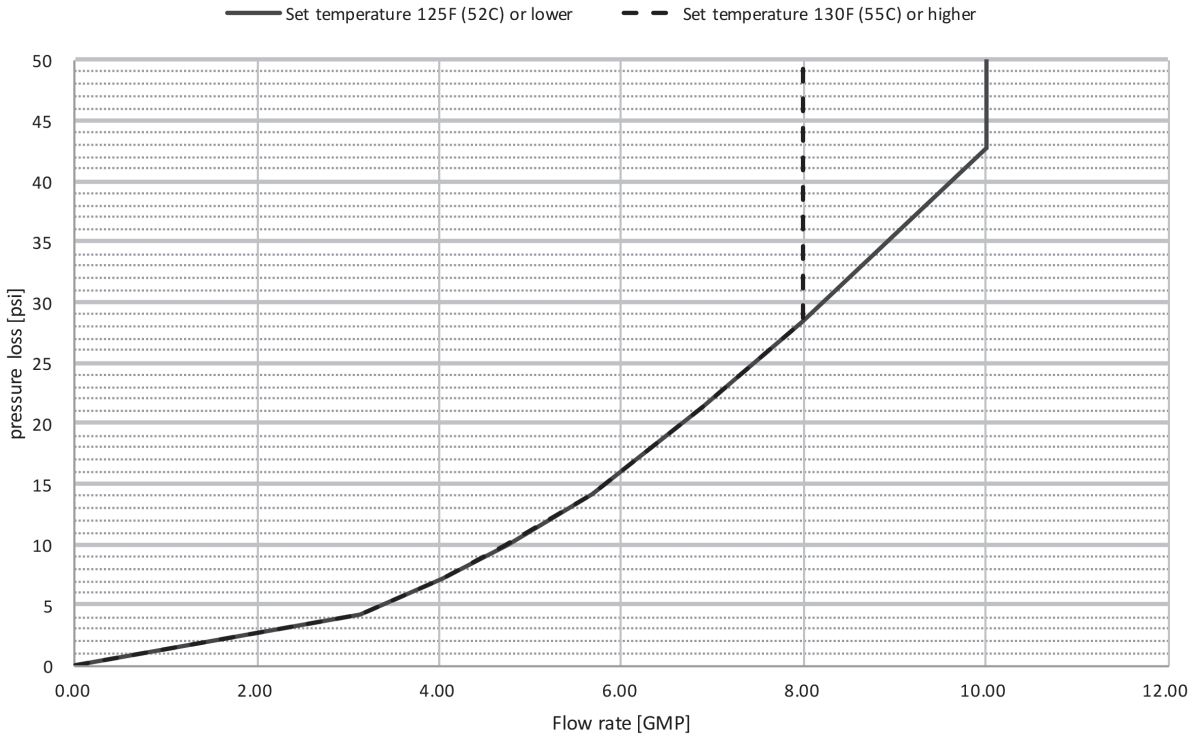

540P Pump Performance

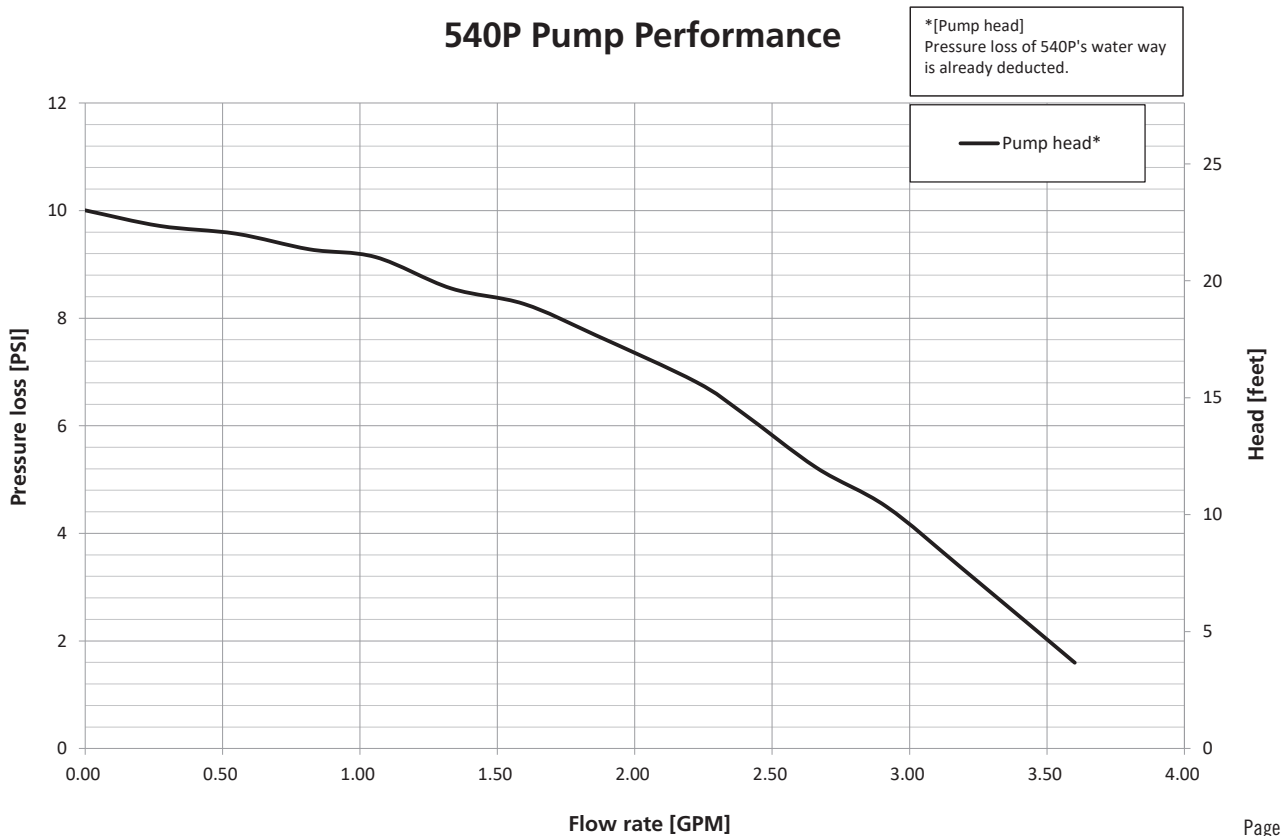

INDOOR MODEL

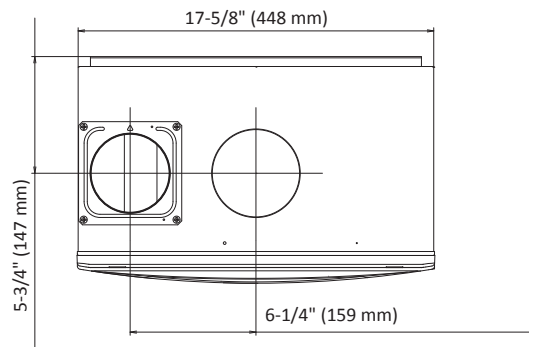
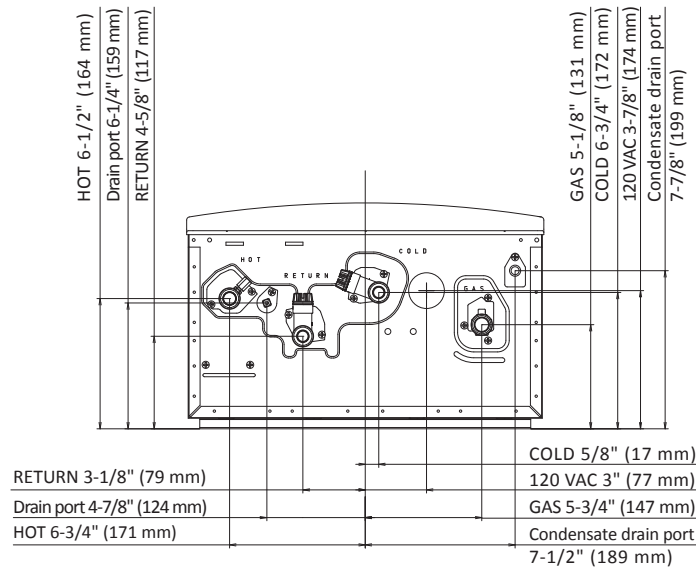
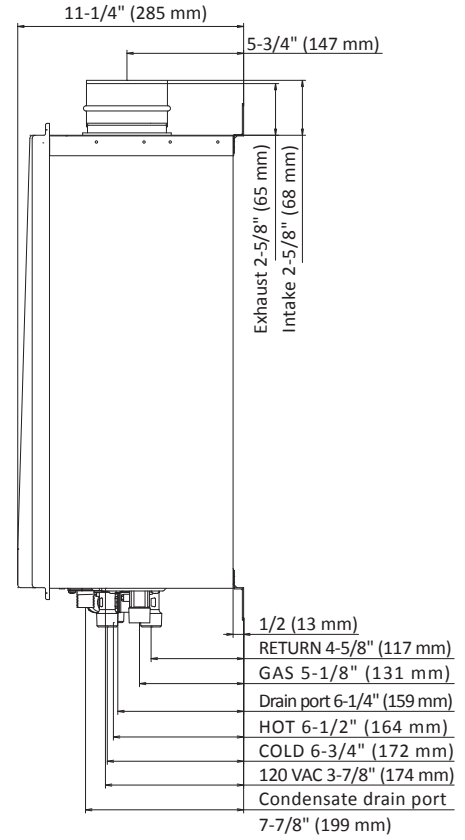
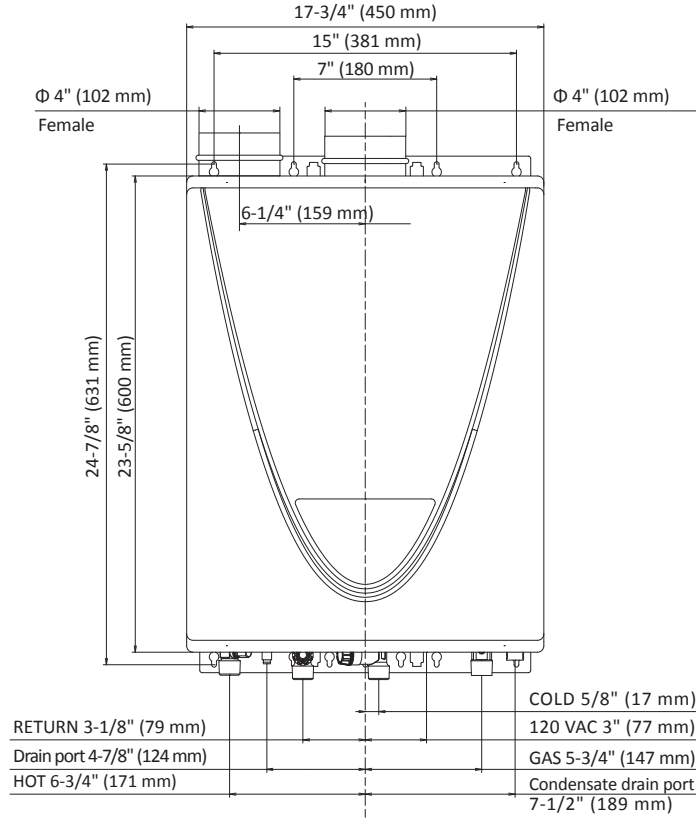

OUTDOOR MODEL

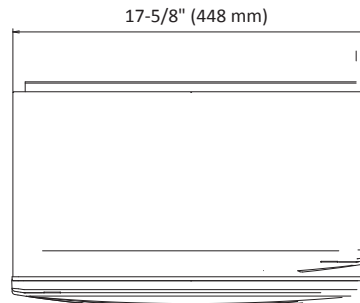
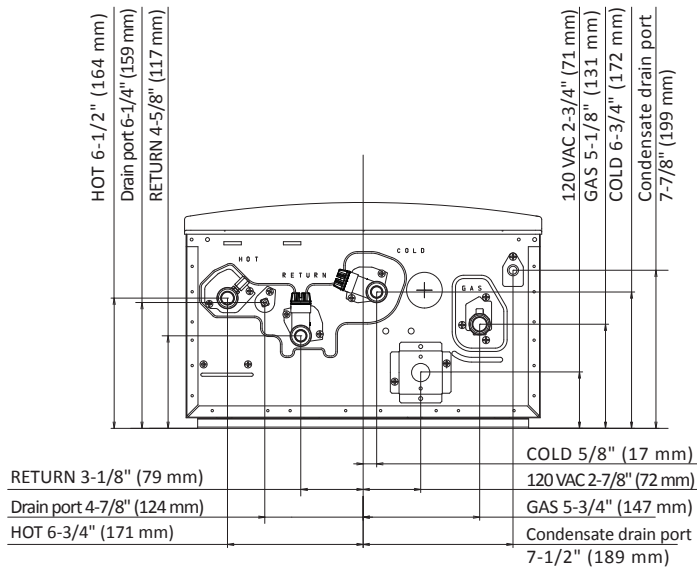
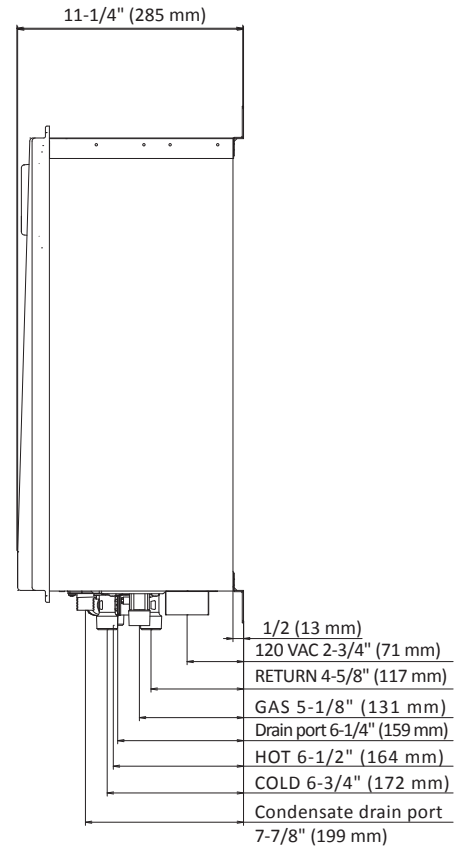
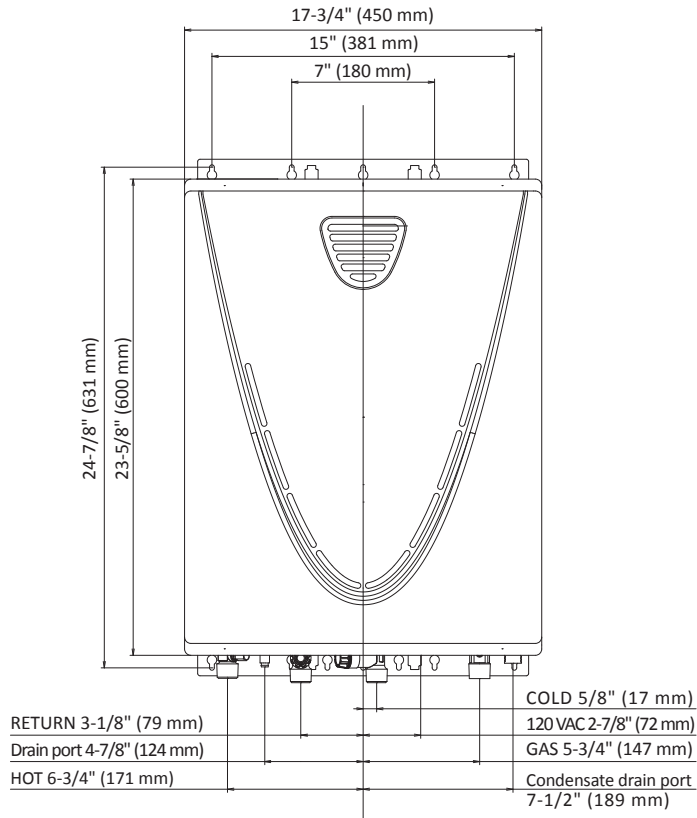



SUGGESTED SPECIFICATIONS FOR THE GTS-540P

The fully modulating, on-demand, condensing gas fired tankless water heater(s) with integrated recirculation pump shall be State Tankless Water Heater model GTS-540P, having a maximum input rating of 199,000 Btu/h and available in NG or LP. The heater shall have ¾ in. male NPT water and gas connections. The inlet gas supply pressures shall be 4.0 in. WC (min.) up to 10.5 in. WC (max.) for NG and 8.0 in. WC (min.) up to 14 in. WC (max.) for LP. The indoor heater(s) shall incorporate an integrated temperature controller that will provide pump control, diagnostic information, fault history, and heater set temperature. The outdoor heater shall be factory supplied with a temperature remote, 100276687, that can be installed up to 400 ft. from the heater using 20 gauge (minimum) control wire. The temperature remote shall provide pump control, diagnostic information, fault history, and heater set temperature. The heater shall operate using 120 V / 60 Hz power source. The indoor heater will incorporate a factory installed power cord.

The indoor heater shall be vented with 3" or 4" diameter schedule 40 PVC (solid core), CPVC, ABS, polypropylene or category IV vent pipe with a length not to exceed 70 ft. (equivalent) for 3" vent or 100 ft. (equivalent) for 4" vent, terminating horizontally or vertically. The intake pipe may use material such as PVC, (solid core) CPVC, ABS, aluminum, or Category IV pipe and cannot exceed 70 ft. (equivalent) for 3" vent or 100 ft. (equivalent) for 4" vent. The indoor heater shall be able to be common vented with schedule 40 PVC (solid core) pipe or approved polypropylene vent with a length not to exceed 100 ft. (equivalent) using up to 10 in. pipe. Proper sizing is provided in the heater's installation manual. The outdoor heater(s) shall be constructed with an integral exhaust vent on the front of the heater.

The water heater shall use a commercial grade copper alloy, fin tube primary heat exchanger with quick release brass or bronze waterways. The secondary heat exchanger shall be constructed from stainless steel 316L. The heater shall be controlled by an onboard solid-state printed circuit board which uses the following factory installed components: thermistors to monitor inlet & outlet water temperature and exhaust temperature; a flow sensor to measure flow rate; a flame sensor to monitor combustion; an air-fuel ratio rod to measure and adjust operation in order to maintain optimal combustion efficiency. The heater also consists of inline fusing and surge absorbers for electrical surge protection, an electronic spark igniter, aluminized stainless steel burners, hi-limit temperature switches to monitor water and exhaust temperatures, modulating gas valve, an overheat cutoff fuse and ceramic heating blocks to protect the heat exchanger and water piping from freezing. The indoor heater shall incorporate auto-fire system and a pump circulation operation for additional freeze protection. The indoor model shall include an exhaust temperature monitoring system using an exhaust thermistor and automatic hi-limit switch to maintain safe exhaust temperatures for sch. 40 PVC. The heater shall have a built-in condensate trap for the secondary heat exchanger.

The heater can manifold into an Easy-Link to provide additional capacity. The Easy-Link controls shall be built onto the onboard solid-state printed circuit board and does not require external controls. The linking control wire shall be supplied with the heater.

The heater shall be design certified by CSA according to ANSI Z21.10.3 • CSA 4.3, approved for sale in the United States, has a minimum uniform energy factor of 0.93, meets the energy efficiency requirements of the U. S. Department of Energy and ASHRAE 90.1 and complies with SCAQMD Rule 1146.2 and other air quality districts with similar requirements for low NOx emissions of 14 ng/J or 20 ppm.